

FEASIBILITY OF USING CORN SHELLER MACHINE IN THRESHING SUNFLOWER

EL-DESOUKEY, N.¹; MOUSA, E.² AND LOTFY, A.²

1- Nat. Res. And Agri. Eng. Dept., Faculty of Agric., Damnhour, Alexandria Univ., Egypt.

2- Ag-Eng. Res. Inst. (AEnRI), Ag. Res. Center, Dokki, El-Giza, Egypt.

ABSTRACT

This research aims to test the feasibility of using a corn sheller machine for threshing sunflower crop.

The effect of some parameters such as drum speed (4.71, 7.85, 10.99 and 14.13 m/s), concave clearance ratio (C1 /C2) (1.2, 1.5, 2.3 and 2.9) type of drum (cranke arrangement at 30°- spike teeth arrangement at 30° - and 90°) on machine productivity (Mg /h) energy requirements (kW.h /Mg) were taken into consideration.

The results revealed that, it is possible to use the corn sheller machine after making some modification on threshing drum and concave in threshing sunflower crop. Optimum operation conditions were obtained with crank cylinder angle 30° at drum speed of (14.13 m/s) cylinder concave clearance ratio (1.2) were gave the best results of threshing efficiency (94.4 %). Lowest grain damage (1.7%), total losses (0.9 %), highest productivity (0.628 Mg / h), energy requirement (2.5 kW.h / Mg), cost L.E / ton (16 L.E. / Mg).

INTRODUCTION

Sunflower (*Helianthus annuus L.*) is one of the important annual crops in the world grown for edible oil (de la Vega and Hall, 2002) and for vegetable oil (Allen, 1983). So, it is recommended to increase the planting area of sunflower in Egypt. It ranks the second after soybeans with respect to oil production. The production and planting area of sunflower in Egypt were 47.31×10^3 Mg and 47857 feddan, respectively during season 2004 with average yield of 0.99 Mg/fed (Arab Organization for Agricultural Development, 2005).

It can be grown in salinity and all types of soil and it can stand water shortage. It can be planted more than one time at the same year. The traditional method for harvesting, threshing, separation and getting grain are laborious time consuming with low production and not economical.

Anwar and Gupta (1990) found that the percentage of mechanical grain damage increased by increasing the cylinder speed and decreased by increasing the concave clearance. Grain damage was in the range of 1.6% to 2.6%. They found that the threshing efficiency was in the range of 90% to 93.1%.

Abdel – Mageed et al. (1994) evaluated the performance of the AEnRS. Locally designed threshing machine in threshing and separating of sunflower seeds. They indicated that for optimum performance, the threshing drum speed and concave clearance should be about 12.82 m/s and 4.5 cm respectively, at 14% seed moisture content. **Morad et al (1997)** reported that drum speed of 10.45 m/s and seed moisture content of 13% were recommended for threshing lupines crop as it recorded both minimum losses and power.

Rizvi et al. (1993) conducted that a study in order to determine a better threshing unit for a sunflower thresher, the study showed that the peg type cylinder with speed range of (400 – 500 rpm) and concave clearance range of (2.5 – 4.4 cm) may be used for developing a threshing unit for a sunflower thresher.

Anil et al. (1998) developed a threshing machine for sunflower seeds. The obtained results indicated that, the percentage of visible damage increased with increasing cylinder speed and decreased with feed rate. Out put increased with increasing cylinder speed and feed rate. Minimum values of damage and peeling occurred at the maximum values of clearance and moisture content and minimum value of drum speed. The percent of minimum total loss was 5.8 % and minimum damage ratio was 3.68 %.

Kausal et al. (2003) concluded that the minimum mechanical damage (3.1%) in sunflower threshing was obtained with the use of thresher a speed of 600 rpm. This threshing speed resulted in good germination (81.4%) and seed purity (95.2 %).

Fluffy and Stone (1983), Geehan and Glasby (1982) found that many investigators evaluated the factors affecting threshing performance such as: concave length, cylinder diameter, cylinder

speed and also factors as clearance, feed rate and moisture content of crops.

Ismail (1988) said that the performance of corn threshing machine is a function of some designing factors such as the diameters of concave holes, drum length in let upon of drum – hopper opening, located number and distanced of long and short drum teeth and number of drum discs, cylinder speed rate and crop moisture content.

Helmy et al. (2000) evaluated the performance of three types of machines on threshing sunflower. They said that the local thresher recorded the minimum values of threshing unit power, cost per unit this may be due to the increase of the threshing productivity.

The main objectives of the present study to evaluate the effect of some parameters such as:

- 1 – Drum types (3 types) (T_1) crank arrangement at 30° ;(T_2) spike teeth 30° and (T_3) spike teeth 90°
- 2 – Peripheral drum speed levels were 4.71, 7.85, 10.9 and 14.13 m/s (300, 500, 700 and 900 r.p.m.).
- 3 – Concave clearance ratio ($C1/C2$) levels were (1.2, 1.5, 2.3 and 2.9).

TEORTICAL CONSIDRETION

The technical condition of any shelling machinery unit depends on shelling drum design parameters such as type of drum, peripheral speed of drum, number of spike teeth on the drum.

According to **klenin (1985)** it was recommended to use spike tooth drum in the shelling unit of modified machine. Since how indicated that, this type of drums has high shelling efficiency, less percentage of losses and damage compared with the other types.

The pitch of sunflower head motion ($L1$) at one revolution of shelling drum which equals 4 $L2$; where $L2$ is the pitch motion of sunflower head which lies between two long teeth respectively in the shelling drum, then:

$$L2 = a (n + 1) \dots\dots\dots (3.1)$$

Where: n = number of short teeth which lie between two long teeth.
a = distance between each of two short teeth.

$$L1 = 4 a (n + 1) \dots\dots\dots (3-2)$$

The number of pitches (p) for sunflower head motion on the drum is expressed in the flowing form:

$$P = 2 (L-A) / L1 \dots\dots\dots (3-3)$$

Where: A = length of drum under feeding hopper (mm)
L = length of shelling drum (mm)
By submitting (L1) from equation (3-2) in equation (3-3) then p could be

$$P = (L - A) / 2a (n + 1) \dots\dots\dots (3-4)$$

On the other hand, the number of long teeth (z2) on the drum equals, the number of pitches of sunflower motion (N) multiplied the number of long teeth pitch (N) for sunflower motion on the drum.

$$\begin{aligned} Z2 &= PN \\ &= N (L-A) / 2a (n+1) \dots\dots\dots (3-5) \end{aligned}$$

But Z1 = T-Z2

where: Z1 = number of short teeth on the drum.
T = total number of teeth on the shelling drum.
The total number of teeth on the drum may be obtained from the equation from:

$$T = m \left(\frac{L}{a} + 1 \right) \dots\dots\dots (3-6)$$

where: m = the number of teeth in each disk. (m = 4 at angle 90°)
Substituting (L) [84, 96, 108 and 120 cm, m = 4]
a = [8, 10, 12 and 14 cm], then T ranged from 31 to 64 teeth.

Substituting $L = 96$, $m = 4$, $a = 12$ cm in equation (3-6) then the total number of teeth equal 36 teeth.

MATERIALS AND METHODS

Field experiments were carried out for threshing sunflower crop (*Helianthus annuus L.*) in a private farm in the Agricultural Experiment Research Station at Gemmiza. To fulfill the objective of this study, a local Egyptian manufactured corn sheller machine had been modified and tested. Fig 1.

Table (1): Technical specification of the corn sheller machine component.

Item	Specification	Dimension
Drum	Type	Spike teeth
	Length (mm)	960
	Diameter (mm)	300
	Number of drum teeth rows	4
	Speed (rpm)	500-800
Concave	Perforated sheet metal	3
	Diameter of the hole (mm)	18
	Thickness (mm)	3
	Diameter (mm)	310
	Distance (mm)	68
Feed hopper	Length (mm)	520
	Width (mm)	370
	Angle of inclination (degree)	45°
	Total length of threshing unit (mm)	1500

A motor, its power 5 kW, has been fixed on the frame to enough for operating the developed corn sheller machine.

Some physical properties and characteristic of sunflower plants varieties were measured and summarized in Table 2.

Table (2): Physical and characteristic of sunflower plants.

Variety HYSUN	Plant height, mm	Head diameter, mm	1000 seeds mass. g	Head thickness mm	Seed yield kg/Fed
	1630.11	170 - 970	55-20	5.4	1195.68

Measurements:**4.1. Threshing capacity:**

The threshing capacity is expressed amount of crop which threshed in time (Mg / h).

$$\text{Threshing capacity} = \frac{W_{tc}}{t}$$

Where:

W_{tc} = weight of total sample before threshing. Mg
 t = time of threshing process. h

4.2. Unthreshed grain losses:

Unthreshed grain losses were calculated as follows:

$$\text{Unthreshed grain losses} = \frac{W_{ug}}{W_{tg}} \times 100$$

Where:

W_{ug} = weight of unthreshed grain. Mg
 W_{tg} = weight of total grain. Mg

4.3. Threshing efficiency:

Threshing efficiency was calculated as follows:

Threshing efficiency = 100 - unthreshed grain losses

It was calculated according to the following equation:

$$\text{Threshing efficiency} = 100 - \frac{W_2}{W_1}$$

Where:

W_1 = the total weight of grain in the samples. Mg
 W_2 = the weight of unthreshed grain in samples. Mg

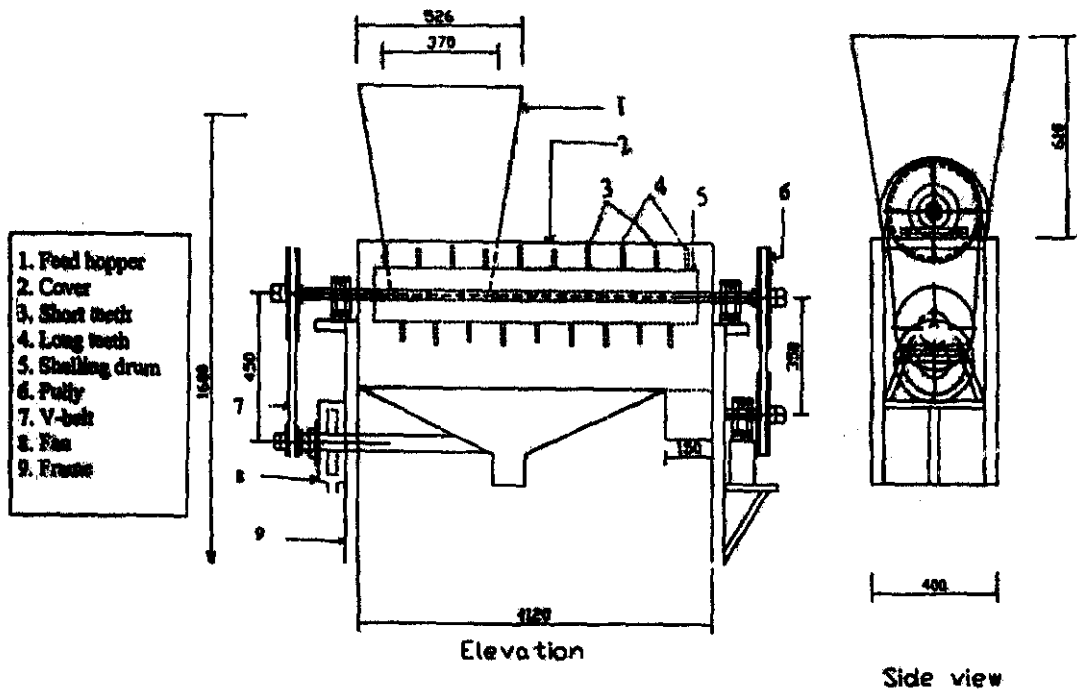

Fig(1) Schematic diagram of shelling corn unit elevation and side view (dim.in mm)

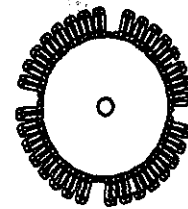
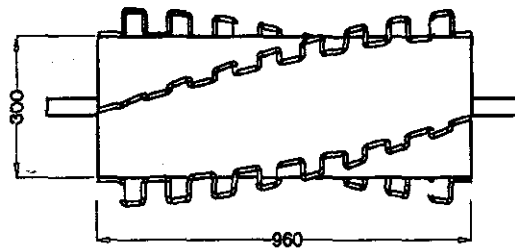

Crank drum 30° {T₁}

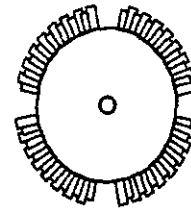
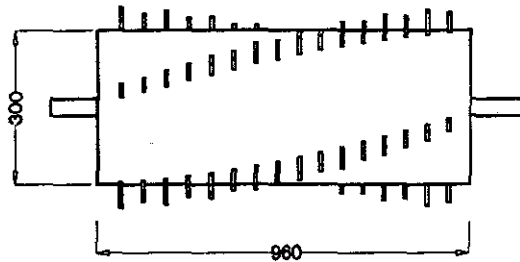

Spike tooth drum 30° {T₂}

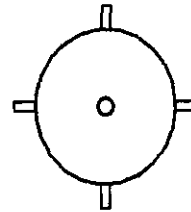
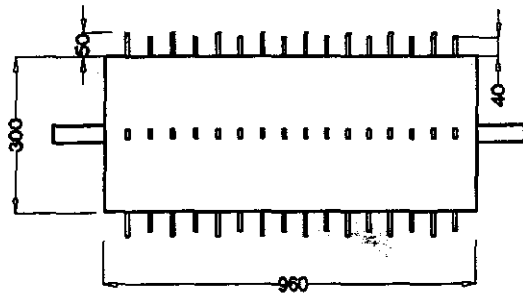

Spike tooth drum 30° {T₃}

Elevation

Side view

Dimensions in mm

Fig. (2) Types of different drums.

4.4. Power requirement:

Ammeter and voltmeter were used for measuring current strength and potential difference, respectively. Readings of Ampere (I) and Volt (V) were taken before and during each treatment. The power consumption (W) was calculated by using the following formula (Lockwood and Dunstan, 1971).

$$\text{Power consumption (W)} = \sqrt{3} \cdot I \cdot V \cdot \text{Cos } \theta \cdot \eta$$

Where:

I = current strength, Amperes;

V = potential difference; Volts;

Cos θ = power factor, decimal (being equal 0.71) and

η = mechanical efficiency of motor assumed 90%.

So, the energy requirement in (kW.h/fed) was calculated as follows:

$$\text{Energy requirement} = \frac{\text{The consumed power (kW)}}{\text{Actual field capacity (Mg/h)}} \dots\dots\dots \text{kW.h/Mg}$$

4.5. Threshing cost:

Machine cost could be determined using the following equation given by Awady (1978),

$$C = \frac{P}{H} \left[\frac{1}{Y} + \frac{i}{2} + T + M \right] + [A.K.F.U] + \frac{S}{144}$$

Where:

C = Hourly cost (L.E/hr),

P = price of machinery (L.E),

H = Yearly working hours (hr/yr),

Y = Life expectancy of the machines (yr),

I = Interest rate/yr,

T = Taxes, over heads ratio,

M = Maintenance and repairs ratio,

A = ratio of rated power and lubrication related to fuel cost (0.75- 0.9) depending on engine performance,

K = Power in kW,

F = Specific fuel- consumption in (L/kW.h),

U = Price of fuel per (L.E/l),

S = Monthly average wage (L.E), and

144: Reasonable estimated working hours.

The total cost of threshing operation was estimated using the following equation, Awady. et al (1982),

$$\text{Threshing cost (L.E / Mg)} = \text{Operating cost} + \text{Grain Losses cost}$$

Operating cost was determined using the following equation:

$$\text{Operating cost} = \frac{\text{Machine cost (L.E / h)}}{\text{Feedrate (Mg / h)}} \dots\dots\dots (\text{L.E / Mg})$$

RESULTS AND DISCUSSION

5.1. Effect of drum speed on threshing efficiency:

Threshing efficiency increased with increasing drum speed as indicated shown in Fig. 3, the data show that increasing drum speed from 4.7 to 7.85 m/sec increased the threshing efficiency from 91.4 to 92.4 %, from 85.6 to 86.8 % and from 79.9 to 81.2 % at the crank drum, spike teeth arrangement at 30° drum and spike teeth arrangement at 90 ° drum respectively. At the same time increasing drum speed from 10.9 to 14.13 m/sec the threshing efficiency increased from 94.2 to 94.9 %, from 87.5 to 88.3 % and from 83.1 to 83.6 % at the same (crank 30°, spike teeth 30° and spike teeth 90°) respectively. This may be due to the increased of impact on sunflower disk with the drum and the increased friction between them, rate with the crank type and less values with the spike 90°. The arrangement of short and long teeth allowed a large quantity of materials to pass through with out loading the engine down or slipping the drive and usually gave adequate threshing.

5.2. Effect of clearance ratio on threshing efficiency:

From the obtained data present in Fig. 4, it is clear that the threshing efficiency increased with decreasing clearance ratio. Results indicated that increasing ratio from 1.2 to 2.2 decrease threshing efficiency from 94.4 to 92.2 %, from 87.9 to 86.3 % and from 82.9 to 80.8 % at of first drum type crank, second drum type (spike teeth with 30°) and third drum type (spike teeth with angle 90°) respectively. The highest of threshing efficiency is obtained at clearance ratio (1.2) was 94.4 %. This is due to the decrease in the friction between the grain and drum.

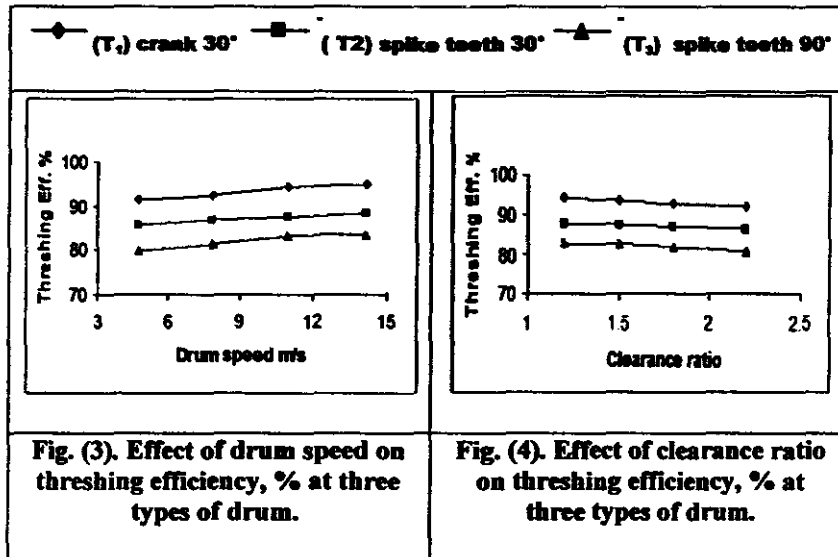

5.3. Effect of drum speed on total grain losses:

Total grain losses decreased with increasing drum speed at three drum types as shown in Fig. 5. From the obtained data, it is clear that increasing of drum speed from 4.7 to 14.13 m/sec decreased the total grain losses from 2.0 to 0.9 %, from 3.1 to 2.3 % and from 3.9 to 2.9 % at crank drum, spike teeth 30° and spike teeth 90° respectively. This may be due to higher grain feeding rate resulted from increasing the drum speed which in turn increase threshing caused by friction effect. The highest value of total grain losses was 3.9 % at drum speed 4.7 m/sec for the spike teeth 90°.

5.4. Effect of clearance ratio on total grain losses:

Data presented in Fig. 6 indicated that, the total grain losses decreased with decreasing clearance ratio. Results indicated that, increasing clearance ratio from 1.2 to 1.5 increased the total grain losses from 1.1 to 1.3 %, from 2.4 to 2.9 % and from 3 to 3.4 % at the three drum types. On the other hand, increasing clearance ratio from 1.8 to 2.2 increased the total grain losses from 1.5 to 1.8 %, 3.2 to 3.5 % and 3.6 to 3.9 % at the crank 30°, spike teeth 30° and spike teeth 90° respectively. The lowest value of clearance ratio (1.2) gave the lowest values of total grain losses (1.1 %).

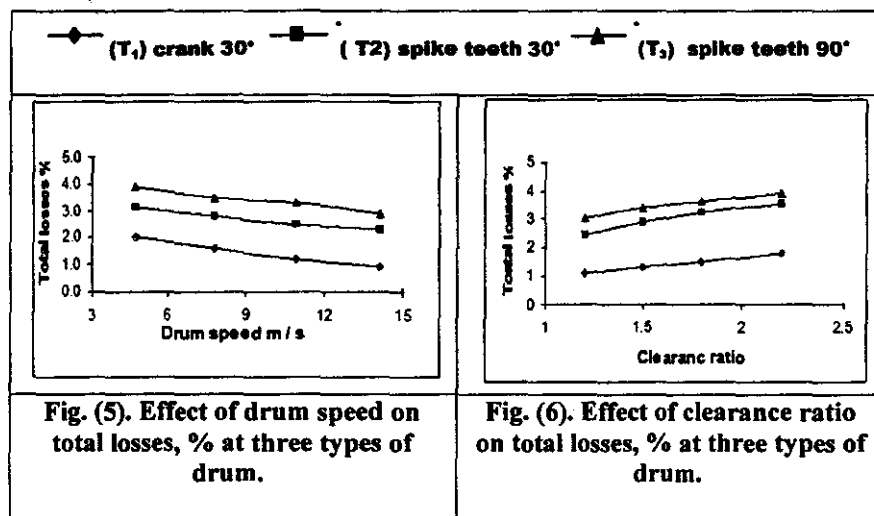

5.5. Effect of drum speed on total kernel damage:

Fig. 7 shows the effect of drum speed m/sec on the total grain damage. Where the total grain damage increased with increasing drum speed. The high increment of total grain damage with increasing drum speed may be attributed only to the great bulk material at high drum speed. This great bulk material as it is known will cause high friction and pressure on the kernel which in turn will cause more damage. From obtained data in Fig. 7 It is clear that the increasing of drum speed from 4.7 to 14.13 m/sec increased the total grain damage from 1.7 to 4.3 %, from 2.1 to 4.8 % and from 2.8 to 5.5 % at the three drum types respectively.

5.6. Effect of clearance ratio on total kernel damage:

Fig. 8 shows that, the total grain damage decreased with increasing clearance ratio. Results indicated that increasing of clearance ratio from 1.2 to 2.2 decreased the total grain damage from 3.9 to 2.1 %, from 4.3 to 2.6 and from 4.9 to 3.3 % at the three drum types respectively.

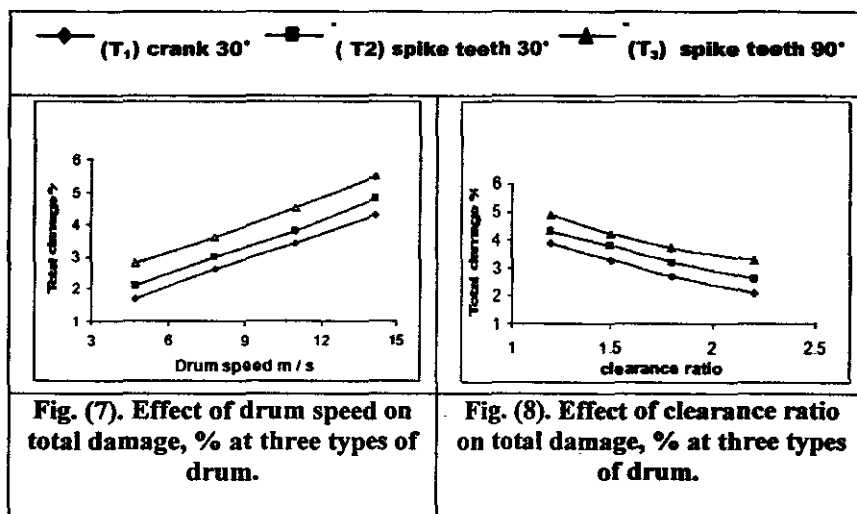

5.7. Effect of drum speed on energy requirements:

Relating to effect of drum speed on the percentage of energy requirements, results in Table 3 show that, increasing drum speed increased energy requirements under all experimental conditions. Increasing drum from 4.17 to 14.13 m/s under crank 30° increased energy requirements, by 2.39 to 2.61 kW.h/Mg. The increased in the energy requirements by increasing drum speed is attributed to the high stripping and impacting forces applied during threshing operation that tend to consume more fuel and increased energy requirements. Table 3.

Table (3): Effect of drum speed on energy requirements

Drum types	Drum speed	Energy requirement kW.h /Mg
T1 Crank 30°	4.17	2.39
	7.85	2.46
	10.9	2.54
	14.13	2.61
T2 Spike tooth 30°	4.17	3.13
	7.85	3.28
	10.9	3.41
	14.13	3.66
T3 Spike tooth 90°	4.17	4.10
	7.85	4.16
	10.9	4.22
	14.13	4.28

5.8. Effect of drum types on energy requirements and productivity:

The energy requirements are a measure for parameters affecting the threshing operation. The threshing cost is affected by many parameters such as drum speed, operating cost and losses cost. Table 4 The first drum type (crank drum) the productivity was 628 kg/h, energy requirement 2.5 kW.h/Mg. The second drum type (spike tooth 30°). the productivity was 543 kg/h and threshing cost 20 L.E/ Mg.

Table (4): Productivity and Energy requirement for three types of drum.

Drum type	Productivity Mg/h	Energy requirement kW.h /Mg	Cost L.E.
Crank 30°(T1)	0.628	2.5	16
Spike tooth 30°(T2)	0.543	3.37	20
Spike tooth 90° (T3)	0.420	4.19	22

CONCOLUSIONS

The results showed that it is possible to use the local threshing machine after macking some modification on the drum and concave in threshing sunflower crop.

The optimum operating conditions of sunflower threshing as follows:

Crank type drum with slope 30° - drum speed (900 r.p.m) 14.13 m / s., concave ratio(C1/C2) 1.2.,grain moisture content 15.5 % (w.b).

REFERANCES

- Abd – Maged, H. N; M.A. El – Saadany and A. S. Hamam (1994).The optimum working conditions of a locally designed machine in threshing sunflower crop. J. Agric. Sci., Mansoura Univ., 19 (10) : 3421 – 3432.
- Allen, R. ; L. D. Swaeth and J. D. Thouas (1983). Sunflower planting and emergence with coated seed. Trans. ASAE, 26(2): 665-668.

- Anil – Joshi; T. Guruswany; S. R. Deasi; J. T. Basavaraj and A. Joshi (1998).** Effect of cylinder speed and feed rate on the performance of thresher. Collage of Agricultural Engineering Raicher – 584101, India Kamataka – Journal of Agricultural Sciences. 1998, 11 (4); 1120 – 1123.
- Anwar, M. T. and C. P. Gupta (1990).** Performance evaluation of chick pea thresher in Pakistan. AMA, 21 (3) : 23 – 28.
- Arab Organization for Agricultural Development(2005).** Arab agricultural statistics yearbook, Volume 25.
- Awady, M. N. (1978).** Tractor and farm machinery. Text book, faculty of Agriculture, Ain-Shams University, Cairo, Egypt. Pp: 164-167.
- Awady, M. N; E. Y. Ghoniem and A. I. Hashish (1982).** A critical comparison between wheat combine harvesters under Egyptian conditions. R. S. No. 1920, Ain-Shams University, J.1982.
- de la Vega, A. J. and A. J. Hall (2002).** Effect of planting date, genotype, and their interactions on sunflower yield: I. Determinants of oil-corrected grain yield. Crop Sci. 42: 1191-1201.
- FAO, (2004),** Production of selected agricultural commodities, Ministry of Agriculture and Land Reclamation. Arab Republic of Egypt
- Fluffy, M. T. and G. T. Stone (1983).** Speed control of a combine harvester to maintain level of measured threshing grain loss. J Agric. Eng. Res., 28: 531 – 543.
- Geehan, M. B. and C. A. Glasby (1982).** The benefits of different speed control system for combine harvesters. J. Agric. Eng. Res., 27 : 537 – 543.
- Helmy, M. A., I. S. Yousef and M. Badawy (2000).** Performance evaluation of some sunflower threshers. Egyp. J. Agri. Res. 79 (2), 2000.
- Ismail, Z. E. (1988).** Evaluation of some parameters affecting corn Sheller performance. Misr J. Ag. Eng., 5 (4) : 393 – 404.
- Kausal, R. T., B. N. Patil; S. R. Kadam and N. R. Pavitrakar (2003).** Case study on harvesting and threshing methods of sunflower Technology Research Unit, 4444, 104 (M.S.), India. Annals of plant physiology; 2003,17 (1): 34 – 38.

- Klenin, N.I; L.F. Popv and V.A Sakun (1985).** Agricultural Machine (Theory of operation of controlling parameters and the conditions of operation) Anerind pup Co. PVT lid, New York.
- Lockwood, F. B. and R. Dunstan (1985).** Electric engineering principles. Meinemann Education Books, L-td, London.
- Morad, M. M.; M. A. Arnaout and A. Mohamed (1997).** Mechanization of Lupinus crop – production under Egyptian condition. Misr J. Ag. Eng., 14 (2); 181 – 192.
- Rizvi, S.H. A., Nadeem – Amjad; and M. A. Shaheen (1993).** Comparative performance of different threshing drums farm sunflower. Farm machinery – Institute. Pakistan Agric. Res. Council. Park Road. Agric. Mech. In Asia – Africa and Latin America. 1993, 24 (1), 23 – 27; 9 ref.

الملخص العربي

إمكانية استخدام آلة تفريط الذرة في دراس عباد الشمس

نبيل النمواقي منصور¹ ابتسام حسن موسى² عبد المحسن لطفي²

1- قسم الموارد الطبيعية والهندسة الزراعية - كلية الزراعة بدمهور - جامعة الاسكندرية

2- معهد بحوث الهندسة الزراعية - مركز البحوث الزراعية

تعتبر عملية الدراس من أكثر العمليات الزراعية مشقة لأنها مازالت تعتمد على العمالة اليدوية التي تحتاج الي وقت كبير لإتمام عملية الدراس بالإضافة الي الفوائد الكبيرة في المحصول نتيجة لذلك. كما يعتبر محصول عباد الشمس من المحاصيل الثنائية الغرض الذي يزرع لغرض استخراج الزيت وكذلك استخدام مخلفاته كعلقة للحيوان وعلى ذلك كان الأهتمام بعملية دراس عباد الشمس حتى نحصل على أعلى كفاءة ممكنة من استخدامه. لذلك أجريت الدراسة على شكل درفيل الدراس المؤثر على أداء آلة تفريط الذرة في دراس عباد الشمس. وقد اشتملت عوامل الدراسة على:

- 1- تصنيع ثلاث أنواع من الدرفيول (على شكل الكرنك بزواوية ميل 30° - درفيل على شكل اسنان بزواوية ميل 30° - درفيل على شكل اسنان بزواوية ميل 90°).
- 2- نسبة الخلوص بين فتحة الدخول والخروج (1.2 - 1.5 - 2.3 - 2.9).
- 3- ربيع سرعات دورانية لدرفيل الدراس (300 - 500 - 700 - 900 لفة / دقيقة) 4.71 - 7.85 - 10.9 - 14.3 م / ث.

و استخدم مستوى رطوبى للحبوب عند 15.15 % على اساس رطب. وأجريت التجربة في محطة البحوث الزراعية بالجيزة و تم دراسة تأثير هذه العوامل على كل من : {كفاءة الدراس والقوالب الكلية للحبوب % ، والنسبة المئوية لكسر الحبوب، والانتاجية ، واستهلاك الوقود}.

وقد أظهرت النتائج المتحصل عليها مايلي :

أن أكفا هذه الدرفيل في الاستخدام هي الكرنك بميل 30° حيث أعطى أعلى كفاءة دراس
94.4% وأقل فواقد للحبوب 0.9% - وأقل فاقد تكسير للحبوب 1.7% - وأعلى
انتاجية 0.628 ميغا جرام / س - كما اعطى نفس الدرفيل أقل استهلاك للطاقة
2.5 كيلو وات . ساعة /ميغا جرام - أقل تكلفة للطن 16 جنية /ميغا جرام.