

A NEW DEVICE (HALF-BALL-CAGE WITH QUEEN EXCLUDER) AND HONEYBEE QUEEN REARING METHOD WITH QUEENRIGHT.

Abou-Ei-Naga, A.M.¹; A.A. Ghanim¹ ; M.E. El-Naggar² and A.M. Zohairy³

1- Economic Entomology Dept., Fac. Agric., Mansoura Univ. Egypt .

2- Agricultural Research Center, Ministry of Agricultural, Egypt .

3- Beekeeping Res. Dept., Plant Protection Res. Inst. Agric. Res. Center, Egypt .

ABSTRACT

This work was carried out to study the following aims: (1) Evaluation of a new device (Half- Ball-Cage with queen excluder) on the acceptance percentage (%) and the weight of emerged virgin queens and produced from the following treatment colonies: a – Queenright colonies ready for supersedure. b- Queenright colonies ready for swarming. c- Queenless colonies. d- Normal queenright colonies chosen it randomly from the apiary colonies. (2) The effect of normal grafting (Doolittle method) using the new cage (Half- Ball-Cage with queen excluder) as well as Zohairy method (modified Jenter) on the acceptance percentage (%) and the weight of emerged virgin queens.

The results showed that, queenright colonies ready for supersedure and swarming recorded the highest acceptance percentage among the tested colonies. While the normal queenright colonies and queenless colonies indicated the lowest acceptance percentage. The queens reared in queenright colonies ready for supersedure and normal queenright colonies recorded the highest values of queen weights. On the other hand queenless queenright colonies ready for swarming showed the lowest values. Zohairy method (modified Jenter) recorded higher levels of acceptance percentage and queen weight than the normal grafting method by using the new cage.

INTRODUCTION

Commercial propagation of queen honeybees is a laborious and time-consuming process that would benefit greatly from the maximization of queen-cell acceptance in larval transplantation procedures or grafting (Laidlaw and Page, 1997). The design of queen cups can significantly affect both acceptance of larvae and characteristics of the queens subsequently produced (Weiss, 1967a and b; Johansson & Johansson, 1978; Ebadi & Gary, 1980). The economic characteristics of the honeybee colony are dependent mainly on the quality of its queen. The queen quality, in turn, depends on both genetic and environmental factors, (Hoopingarner and Farrar, 1959). The rearing conditions that offered by nursery colonies are the most important requirement among the ecological factors to obtain good queens, (Johansson & Johansson, 1973; Chang 1977 ; Skowronek and Skubida 1988 ; Abou El-Enain, (2000) ; Zohairy, 2001 ; Mohammad 2002 ; Mustafa *et. Al.* 2002 and Abd Al- Fattah *et al.* 2003). For characterizes of brood pheromones and larvae presence into queen rearing colonies where it increased the acceptance of the queen cells, enhanced the amounts of royal jelly deposited by the worker, improved the weight of the larvae. also act as a

primer pheromone in the regulation of division of labour among adult workers. Hypopharyngeal gland development and protein biosynthesis compound. Variable inhibition of worker bee ovary development. Attractant–induces mild retinue-like response. Foraging ontogeny and forage choice behavior . Modulation of worker sucrose response thresholds, (Le Conte *et al.* 1995 and 2001., Pankiw *et al.* 2004).

In the main time, many problems were behaved the commercial beekeeping according to the used methods of queen rearing. Thus, this work was carried out to study the following aims: (1) Evaluation of a new device (Half- Ball-Cage with queen excluder) on the acceptance percentage and the weight of emerged virgin queens and produced from the following treatment colonies: a – Queenright colonies ready for supersedure. b- Queenright colonies ready for swarming. c- Queenless colonies. d- Normal queenright colonies chosen it randomly from the apiary colonies. (2) The effect of normal grafting (Doolittle method) using the new cage (Half- Ball-Cage with queen excluder) as well as Zohairy method (modified Jenter) on the acceptance percentage (%) and the weight of emerged virgin queens.

MATERIALS AND METHODS

This work was carried out in a private apiary at El- Manzala region, El-Dakahleya Governorate, Egypt, during the year of 2002 and 2003.

(1) **Description of the new device (Half- Ball-Cage with queen excluder):** This cage is made of a thin metal plate stripe(1), with fold (dosra)(2), this stripe round as ring form with diameter 5 cm (3), fixed it half-ball with queen excluder wire(4), which are big enough to allow nurse workers to pass through it to feed the larvae , but not allow the queen to pass through it (fig.1).

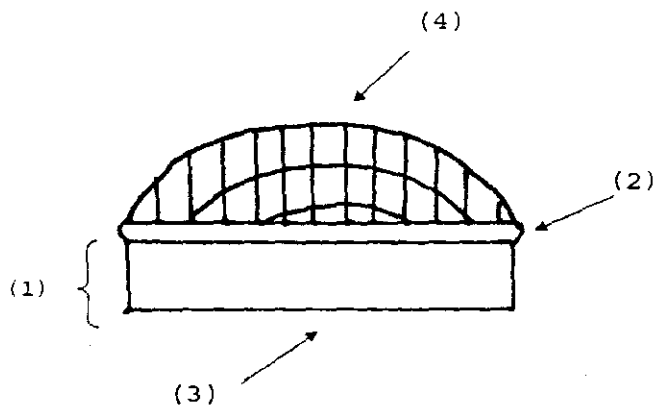

(Fig. 1) A new device (half-ball-cage with queen excluder) for Queen rearing .

(2) Tested colonies :-

A- Evaluation of a new device (Half- Ball-Cage with queen excluder) on the acceptance percentage and the weight of emerged virgin queens. 16 honeybee colonies of Craniolan race of El- Manzala were used to this study. The colonies were classified into four groups (four colonies each) as follows: -

- 1- Queenright colonies and ready for supersedure .
- 2- Queenright colonies and ready for swarming .
- 3- Queenless colonies .
- 4- Normal queenright colonies chosen it randomly from the apiary colonies.

Each tested colonies in each group was provided with five grafted queen cups with larvae (less than 24 hr.). The tested grafted queen cups were on open brood comb in the tested colonies. These cups were engaged with the new cage (Half- Ball-Cage with queen excluder), which enable nurse workers to enter and feed the queen larvae with royal jelly. The acceptance percentage (%) of the grafted queen cups and the weight of emerged virgin queens were recorded for each colony in each group.

B- The effect of normal grafting (Doolittle method) using the new cage (Half- Ball-Cage with queen excluder) as well as Zohairy method (modified Jenter) on the acceptance percentage (%) and the weight of emerged virgin queens. Four strong queenright colonies (Craniolan race of El- Manzala) were conducted for this study. Each colony was provided with seven grafted queen cups using Doolittle method (normal grafting method) (grafted larvae were less than 24 hr.). Anther seven queen cups were obtained from Zohairy method (modified Jenter) , were also introduced to each colony. The total queen cups for each tested colony was 14. The queen cups were engaged with the new cage (Half- Ball-Cage with queen excluder), which enable nurse workers to enter and feed the queen larvae with royal jelly. The acceptance percentage (%) of the grafted queen cups and the weight of emerged virgin queens were recorded for each colony.

RESULTS AND DISCUSSION

(1) Evaluation of a new cage (Half- Ball-Cage with queen excluder) on the acceptance percentage and the weight of emerged virgin queens.

a - Acceptance percentage (%):-

The statistical analysis of data obtained in Table (1) in the first year, 2002 from 23 / 4 / 2002 , 5 / 5 / 2002 and 14 / 5 / 2002 showed that : -

On 23/4/2002, there were insignificant differences for acceptance percentage among each of [supersedure queenright colonies(super.q.r.col.)], [swarming queenright colonies (swarm.q.r.col.)] and [queenless colonies (queenless col.)] which were (95 ± 8.66 , 95 ± 8.66 and $95 \pm 8.66\%$), respectively and significant differences between each of them and [normal queenright colonies randomly chosen (n.q.r. randomly)] one which was ($60 \pm 20\%$). On 5/5/2002, there were insignificant differences among each of (super.q.r.col.), (swarm.q.r.col.), (queenless col.) and (n.q.r. randomly) which were (100 ± 0.0 , 100 ± 0.0 , 95 ± 8.66 and $85 \pm 16.583 \%$), respectively. On 14/5/2002, there were insignificant differences among each

of (super.q.r.col.), (swarm.q.r.col.) and (queenless col.) which were (100 a ± 0.0, 100 a ± 0.0 and 100 a ± 0.0 %), respectively and significant differences between each of them and (n.q.r. randomly) one which was (90 b ± 10 %). Also, there were insignificant differences in average of dates among each of (super.q.r.col.), (swarm.q.r.col.) and (queenless col.) which were (98.325 a ± 2.901, 98.325 a ± 2.901 and 96.65 a ± 3.35 %) respectively and significant differences between each of them and (n.q.r. randomly) one which was (78.3 b ± 5.517%).

b – Weight of emerged queens :-

On 23 / 4 / 2002 , there were insignificant differences for weight of emerged queens among the four groups (super.q.r.col.) , (swarm.q.r.col.) , (queenless col.) and (n.q.r. randomly) which were, (162 a ± 2.449, 159.5 a ± 0.866 , 161 a ± 2.236 and 161.25 a ± 2.165 mg.) , respectively . And on 5 / 5 / 2002 were (162 a ± 1.414 , 160 a ± 1.291 , 160.5 a ± 1.732 and 161 a ± 1.732 mg.) , respectively. But, on 14 / 5 / 2002, there were significant differences between (super.q.r.col.) and (swarm.q.r.col.). While there were insignificant differences among (super.q.r.col.) and both of (queenless col.) and (n.q.r. randomly) groups. Also, there were insignificant differences among (swarm.q.r.col.) and both [(queenless col.) and (n.q.r. randomly)]. The weights were (163 a ± 1.732 , 159.5 b ± 0.866 , 162 ab ± 1.414 and 162.25 ab ± 2.277 mg.)for each of (super.q.r.col.), (swarm.q.r.col.), (queenless col.) and (n.q.r. randomly), respectively. There were insignificant differences in average of dates among each of (super.q.r.col.) (queenless col.) and (n.q.r. randomly) which were (162.31 a ± 0.315, 161.08 a ± 0.637 and 161.49 a ± 1.067 mg.) respectively and highly significant differences between each of them and (swarm.q.r.col.) one which was (159.643 b 0.725 mg.).

Table (1) in 2002, Evaluation of a new device (Half- Ball-Cage with queen excluder) on the acceptance percentage (%) and the weight of emerged virgin queens and produced from the following treatment colonies: 1– Queenright colonies ready for supersedure. 2- Queenright colonies ready for swarming. 3- Queenless colonies. 4- Normal queenright colonies chosen it randomly from the apiary colonies.

Dates Methods	23/4/2002	5/5/2002	14/5/2002	Average
Acceptance percentage (%)				
1supersed.	95 a ± 8.66	100 a ± 0.0	100 a ± 0.0	98.325 a ± 2.901
2 swarming	95 a ± 8.66	100 a ± 0.0	100 a ± 0.0	98.325 a ± 2.901
3 qu. less	95 a ± 8.66	95 a ± 8.66	100 a ± 0.0	96.65 a ± 3.35
4 randomly	60 b ± 20	85 a ± 16.583	90 b ± 10	78.3 b ± 5.517
LSD at 5%	22.237	16.640	8.894	6.803
Weight of emerged queens (mg)				
1Supersed	162 a ± 2.449	162 a ± 1.414	163 a ± 1.732	162.31 a ± 0.315
2 swarming	159.5 a ± 0.866	160 a ± 1.291	159.5 b ± 0.866	159.643 b + 0.725
3 qu. less	161 a ± 2.236	160.5 a ± 1.732	162 ab ± 1.414	161.08 a ± 0.637
4 randomly	161.25 a ± 2.165	161 a ± 1.732	162.25 ab ± 2.277	161.49 a ± 1.067
LSD at 5%	3.606	3.0490	2.941	1.352

Values followed by the same letter are not significantly different at the 5% level of probability.

Table (2) in 2003, Evaluation of a new device (Half- Ball-Cage with queen excluder) on the acceptance percentage (%) and the weight of emerged virgin queens and produced from the following treatment colonies: 1- Queenright colonies ready for supersedure. 2- Queenright colonies ready for swarming. 3- Queenless colonies. 4- Normal queenright colonies chosen it randomly from the apiary colonies.

Dates Methods	27/4/2003	2/5/2003	22/5/2003	Average
Acceptance percentage (%)				
1Supersed	95 a ± 8.66	100 a ± 0.0	100 a ± 0.0	98.32 a ± 2.901
2 swarming	95 a ± 8.66	95 a ± 8.66	100 a ± 0.0	96.66 a ± 5.776
3 qu.less	95 a ± 8.66	95 a ± 8.66	95 a ± 8.66	95.98 a ± 5.36
4 randomly	60 b ± 14.142	70 b ± 10	85 b ± 8.66	75.647 b ± 12.064
LSD at 5%	18.337	14.064	10.894	13.139
Weight of emerged queens (mg)				
1Supersed	162.5 a ± 1.658	163.5 a ± 0.866	163 a ± 3.316	162.99 a ± 0.580
2 swarming	159.5 a ± 2.179	160 b ± 0.0	159.5 a ± 0.866	159.66 c ± 0.998
3 qu.less	159.5 a ± 0.866	160.5 b ± 2.179	161.5 a ± 1.658	160.496 bc ± 0.726
4 randomly	160.5 a ± 2.179	161.45 ab ± 1.486	161 a ± 1.732	161.235 b ± 0.887
LSD at 5%	3.199	2.469	3.721	1.447

Values followed by the same letter are not significantly different at the 5% level of probability.

A - Acceptance percentage (%): -

While in the second year, 2003, the statistical analysis of data obtained in Table (2) from 27 / 4 / 2003 , 2 / 5 / 2003 and 22 / 5 / 2003 showed that : -

On 27 / 4 / 2003 , there were insignificant differences for acceptance percentage among each of (super.q.r.col.) , (swarm.q.r.col.) and (queenless col.) which were (95 a ± 8.66, 95 a ± 8.66 and 95 a ± 8.66 %) respectively and highly significant differences between each of them and (n.q.r. randomly) one which was (60 b ± 14.14 %). Also , on 2 / 5 / 2003 , there were insignificant differences among each of (super.q.r.col.), (swarm.q.r.col.) and (queenless col.) which were (100 a ± 0.0, 95 a ± 8.66 and 95 a ± 8.66 %) respectively and highly significant differences between each of them and (n.q.r. randomly) one which was (70 b ± 10). Also too, on 2 / 5 / 2003 , there were insignificant differences among each of (super.q.r.col.), (swarm.q.r.col.) and (queenless col.) which were (100 a ± 0.0, 100 a ± 0.0 and 95 a ± 8.66 %) respectively and highly significant differences between each of them and (n.q.r. randomly) one which was (85 b ± 8.66 %). There were insignificant differences in average of dates among each of (super.q.r.col.), (swarm.q.r.col.) and (queenless col.) which were (98.32 a ± 2.901, 96.66 a ± 5.776 and 95.98 a ± 5.36 %) respectively and highly significant differences between each of them and (n.q.r. randomly) one which was (75.647 b ± 12.064 %).

B – Weight of emerged queens : -

On 27 / 4 / 2003, there were insignificant differences for weight of emerged queens among the four methods (super.q.r.col.), (swarm.q.r.col.), (queenless col.) and (n.q.r. randomly) which were (162.5 a ± 1.658, 159.5 a

± 2.179 , $159.5 a \pm 0.866$ and $160.5 a \pm 2.179$ mg.), respectively. On 2 / 5 / 2003, there were significant differences among (super.q.r.col.) and both [(swarm.q.r.col.) and (queenless col.)], while there were insignificant differences between (super.q.r.col.) and (n.q.r. randomly), also between both [(swarm.q.r.col.) and (queenless col.)] and (n.q.r. randomly), also between (swarm.q.r.col.) and (queenless col.). The heaviest weight was [$163.5 a \pm 0.866$ mg . for (super.q.r.col.)], then [$161.45 ab \pm 1.486$ mg. for (n.q.r. randomly)]. The lowest were both [($160 b \pm 0.0$ and $160.5 b \pm 2.179$ mg. for (swarm.q.r.col.) and (queenless col.), respectively]. On 22 / 5 / 2003, there were insignificant differences among the four methods (super.q.r.col.), (swarm.q.r.col.), (queenless col.) and (n.q.r. randomly) which were ($163 a \pm 3.316$, $159.5 a \pm 0.866$, $161.5 a \pm 1.658$ and $161 a \pm 1.732$ mg.), respectively. There were highly significant differences in average of dates between (super.q.r.col.) and each of [(swarm.q.r.col.), (queenless col.) and (n.q.r. randomly)]. Also , between (swarm.q.r.col.) and (n.q.r. randomly). While there were insignificant differences between (queenless col.) and (n.q.r. randomly), also between (swarm.q.r.col.) and (queenless col.). The heaviest weight was [$162.99 a \pm 0.580$ mg. for (super.q.r.col.)], then [$161.235 b \pm 0.887$ mg. for (n.q.r. randomly)], then [$160.496 bc \pm 0.726$ mg. for (queenless col.)]. The lowest was [$159.66 c \pm 0.998$ mg. for (swarm.q.r.col.)].

Table (3) in 2002 and 2003, Evaluation of a new device (Half- Ball-Cage with queen excluder) on the acceptance percentage (%) and the weight of emerged virgin queens and produced from the following treatment colonies: 1- Queenright colonies ready for supersedure. 2- Queenright colonies ready for swarming. 3- Queenless colonies. 4- Normal queenright colonies chosen it randomly from the apiary colonies.

Years Methods	2002	2003	Average
Acceptance percentage (%)			
1Supersed	98.325 a \pm 2.901	98.32 a \pm 2.901	98.22 a \pm 1.780
2 swarming	98.325 a \pm 2.901	96.66 a \pm 5.776	97.48 a \pm 2.777
3 qu.less	96.65 a \pm 3.35	95.98 a \pm 5.36	95.81 a \pm 2.781
4 randomly	78.3 b \pm 5.517	75.647 b \pm 12.064	76.96 b \pm 5.211
LSD at 5%	6.803	13.139	6.7147
Weight of emerged queens (mg)			
1Supersed	162.31 a \pm 0.315	162.99 a \pm 0.580	162.54 a \pm 0.287
2 swarming	159.643 b 0.725	159.66 c \pm 0.998	159.65 c \pm 0.625
3 qu.less	161.08 a \pm 0.637	160.496 bc \pm 0.726	160.82 b \pm 0.372
4 randomly	161.49 a \pm 1.067	161.235 b \pm 0.887	161.36 b \pm 0.487
LSD at 5%	1.352	1.447	0.8142

Values followed by the same letter are not significantly different at the 5% level of probability.

A - Acceptance percentage (%) :-

The statistical analysis of data obtained in Table (3) (Average of 2002 and 2003) showed that:-

In 2002, there were insignificant differences for acceptance percentage among each of (super.q.r.col.), (swarm.q.r.col.) and (queenless

col.) which were (98.325 a ± 2.901, 98.325 a ± 2.901 and 96.65 a ± 3.35 %) respectively and highly significant differences between each of them and (n.q.r. randomly) one which was (78.3 b ± 5.517 %). Also, in 2003, there were insignificant differences among each of (super.q.r.col.), (swarm.q.r.col.) and (queenless col.) which were (98.32 a ± 2.901, 96.66 a ± 5.776 and 95.98 a ± 5.36 %) respectively and highly significant differences between each of them and (n.q.r. randomly) one which was (75.647 b ± 12.064 %). There were insignificant differences in average of two years among each of (super.q.r.col.), (swarm.q.r.col.) and (queenless col.) which were (98.22 a ± 1.780, 97.48 a ± 2.777 and 95.81 a ± 2.781 %) respectively and significant differences between each of them and (n.q.r. randomly) one which was (76.96 b ± 5.211 %).

B – Weight of emerged queens : -

In 2002, there were insignificant differences for weight of emerged queens among each of (super.q.r.col.), (queenless col.) and (n.q.r. randomly) which were (162.31 a ± 0.315, 161.08 a ± 0.637 and 161.49 a ± 1.067 mg.) respectively and highly significant differences between each of them and (swarm.q.r.col.) one which was (159.643 b ± 0.725 mg.). In 2003, there were highly significant differences among (super.q.r.col.) and each of [(swarm.q.r.col.), (queenless col.) and (n.q.r. randomly)]. Also, between (swarm.q.r.col.) and (n.q.r. randomly). While there were insignificant differences between (queenless col.) and (n.q.r. randomly), also between (swarm.q.r.col.) and (queenless col.). The heaviest weight was [162.99 a ± 0.580 mg. for (super.q.r.col.)], then [161.235 b ± 0.887 mg. for (n.q.r. randomly)], then [160.496 bc ± 0.726 mg. for (queenless col.)]. The lowest was [159.66 c ± 0.998 mg. for (swarm.q.r.col.)]. There were significant differences in average of two years between (super.q.r.col.) and each of [(swarm.q.r.col.), (queenless col.) and (n.q.r. randomly)]. Also, among (swarm.q.r.col.) and each of [(queenless col.) and (n.q.r. randomly)]. While, there were insignificant differences between (queenless col.) and (n.q.r. randomly). The heaviest weight were 162.54 a ± 0.287 mg. for (super.q.r.col.), then 161.36 b ± 0.487 mg. for (n.q.r. randomly), and 160.82 b ± 0.372 mg. for (queenless col.). The lowest weight was 159.65 c ± 0.625 mg. for (swarm.q.r.col.).

(2) The effect of normal grafting (N.G.M.) (Doolittle method) using the new cage (Half- Ball-Cage with queen excluder) as well as Zohairy method (Z.M.) (modified Jenter) on the acceptance percentage (%) and the weight of emerged virgin queens.

The statistical analysis of data obtained in Table (4) for 25 / 4 / 2002, 8 / 5 / 2002, 5 / 5 / 2003 and 19 / 5 / 2003 showed that:-

A - Acceptance percentage (%) : -

On 25 / 4 / 2002, there were insignificant differences for acceptance percentage between (Z.M.) and (N.G.M.) which were (96.42 a ± 6.18 and 89.28 a ± 6.18 %), respectively. On 8 / 5 / 2002, there were significant differences between (Z.M.) and (N.G.M.) which were (100 a ± 0.0 %) and (85.7 b ± 10.1 %), respectively. Also, on 5 / 5 / 2003, there were significant differences between (Z.M.) and (N.G.M.) which were (100 a ± 0.0 %) better than (89.28 b ± 11.84 %), respectively. On 19 / 5 / 2003, there were

insignificant differences between (Z.M.) and (N.G.M.) which were (100 a ± 0.0 and 92.85 a ± 7.14 %), respectively. There were significant differences in average of dates between (Z.M.) and (N.G.M.) which were (99.1 a ± 1.55 %) and (89.297 b ± 2.527 %), respectively.

B – Weight of emerged queens : -

On 25 / 4 / 2002, there were insignificant differences for weight of emerged queens between (Z.M.) and (N.G.M.) which were (161.06 a ± 1.18 and 159.52 a ± 1.29 mg.), respectively. On 8 / 5 / 2002, there were significant differences between (Z.M.) and (N.G.M.) which were (162.85 a ± 1.43 mg.) and (160.43 b ± 0.83 mg.), respectively. Also, on 5 / 5 / 2003, there were significant differences between (Z.M.) and (N.G.M.) which were (163.56 a ± 1.23 mg.) and (161.127 b ± 1.20 mg.), respectively. On 19 / 5 / 2003, there were insignificant differences between (Z.M.) and (N.G.M.) which were (163.56 a ± 0.71 and 161.60 a ± 2.04 mg.), respectively. There were significant differences in average of dates between (Z.M.) and (N.G.M.) which were (162.75 a ± 0.458 mg.) and (160.8 b ± 0.318 mg.), respectively.

Table (4) The effect of normal grafting (N.G.M.) (Doolittle method) using the new cage (Half- Ball-Cage with queen excluder) as well as Zohairy method (Z.M.) (modified Jenter) on the acceptance percentage (%) and the weight of emerged virgin queens.

Dates Methods	25/4/2002	8/5/2002	5/5/2003	19/5/2003	Average
Acceptance percentage (%)					
1(N.G.M.)	89.28 a ± 6.18	85.7 b ± 10.1	89.28 b ± 11.84	92.85 a ± 7.14	89.297 b ± 2.527
2(Z.M.)	96.42 a ± 6.18	100 a ± 0.0	100 a ± 0.0	100 a ± 0.0	99.1 a ± 1.55
LSD at 5%	12.371	14.270	10.71	10.597	4.189
Weight of emerged queens (mg)					
1(N.G.M.)	159.52 a ± 1.29	160.43 b ± 0.83	161.127 b ± 1.20	161.60 a ± 2.04	160.8 b ± 0.318
2(Z.M.)	161.06 a ± 1.18	162.85 a ± 1.43	163.56 a ± 1.23	163.56 a ± 0.71	162.75 a ± 0.458
LSD at 5%	2.472	2.015	2.439	3.058	0.757

Values followed by the same letter are not significantly different at the 5% level of probability.

Results of obtained data were agreement with Chang (1977) in Taiwan, he reported that queen cell cups acceptance were better in a colony with an old queen (supersedure) than in one with a young queen, but royal jelly production was relatively similar in both. Also, agreed with Zohairy (2001) in Egypt, he concluded that, Zohairy method was better than Doolittle method (normal grafting method) for acceptance percentage . Also, agreed with Le Conte *et al.* (1995 and 2001) in France. Also, with Pankiw *et al* (1995 and. 2004) in USA for characterizes of brood pheromones and larvae presence into queen rearing colonies where it increased the acceptance of the queen cells, enhanced the amounts of royal jelly deposited by the worker, improved the weight of the larvae. also act as a primer pheromone in the regulation of division of labour among adult workers. Hypopharyngeal gland development and protein biosynthesis compound. Variable inhibition of worker bee ovary development. Attractant–induces mild retinue-like response. Foraging

ontogeny and forage choice behavior. Modulation of worker sucrose response thresholds.

Additions collecting all young nurse workers on brood comb. Not appearance the laying workers (false mothers), therefore the rearing colony not dwindling. Brood pheromone active the bees specially for nectar and pollens collecting and all other activities make relax, stay and calmness to workers. Larvae presence gave hope to workers for queen rearing when grafted queen cups unsuccessful, or when loss emerged queens. Continuance of larvae and sealed brood make presence workers different ages, where each age have special works. Can queen rearing to more time and long time.

It is recommended with using this new cage with Zohairy method for queen rearing with queenright and brood combs inside strong colony of the apiary (rate 15 queen cups per a colony).

REFERENCES

- Abd-Al-Fattah M.A. , M.N. El-Basiony and H.M.Mahfouz (2003). Biological and biometrical characters of queen (*Apis mellifera* L.) artificially reared by different grafting techniques in North Sinai , Egypt. *J. Agric. Sci. Masoura Univ.*, 28(8): 6399 – 6406, 2003 .
- Abou El-Enain, H. T. (2000). Rearing and improving the quality of queen honeybees by using some ideal methods . *J. Agric. Sci., Mansoura Univ.*, 25 (12): 8109 – 8117.
- Chang, S. Y. (1977). Effects of size and type of queen cup on the production of royal jelly and acceptance by nurse bees M. sc. Thesis, national chung Hsing Univ., Taichung, Taiwan (*Apic. Abst.*, 201/79) .
- Doolittle, G.M. (1888). *Scientific Queen- Rearing*. Am. Bee J. Hamilton, Illinois, USA. (C.F. Laidlaw, Jr. and J.E. Ecksrt, 1950).
- Ebadi, R.; N.E. Gary (1980). Acceptance by honeybee colonies of larvae in artificial queen cells. *J. Apic Res.*, 19 (2): 127 – 132.
- Hoopingartner, R. and G. L.Farrar (1959). Genetic control of size in queen honeybees. *USDA J. Econ. Entomol.*, 52 (4): 547 – 548.
- JohanssonT.S. , M.P.Johansson (1978). Some important operation in bee management. London :International BeeResearch Association.
- Laidlaw, H.H. and R.E. Page (1997). "Queen Rearing and Bee Breeding". *Univ. of California, Davis, USA*, (224).
- Le Conte Y., L. Sreng and S. H. Poitout (1995) . Brood pheromone can modulate the feeding behavior of *Apis mellifera* workers (Hymenoptera : Apidae). *Journal of economic entomology (J. econ. entomol.)* ISSN 0022-0493 , 1995 , vol . 88 , no4 , pp. 798 - 804 (27 ref.).
- Le Conte Y. , A. Mohammadi and G. E. Robinson (2001) . Primer effects of brood pheromone on honeybee behavioral development . *Proceeding of the Royal Society B: Biological Sciences* , Issue : Volume 268 , Number 1463 / January 22 , 2001 , Pages: 163 - 168 .
- Mohammad, R. E. H. (2002). Studies on rearing and production of honeybee queen , *Apis mellifera* L. Ph. D. thesis, Fac. Agric. , Zagazig Univ., 189p.

- Mustafa M. A. , S. S. Saleh and A. D. Mohamed (2002). Some morphological characters of queen honey bee *Apis mellifera carnica* according to different localities and seasonal variations . J. Agric. Sci. Masoura Univ., 27(4): 2587–2599, 2002 .
- Pankiw T., M. L. Winston and K. N. Slessor (1995). Queen attendance behavior of worker honey bees (*Apis mellifera* L.) that are high and low responding to queen mandibular pheromone. Journal Insectes Sociaux Issue Volume 42 , Number 4 /December, 1995 , pages 371- 378 , Canada.
- Pankiw T. , R. Roman , R.R. Sagili and K. Zhu-Salzman (2004). Pheromone-modulate behavioral suites influence colony growth in the honey bee (*Apis mellifera*). Naturwissenschaften. 2004 Dec;91(12):575-8. Epub 2004 .
- Skowronek, W. and P. Skubida (1988). The effect of internal conditions in the honeybee colony on queen rearing and the quality of queens. Pszczelnicze Zeszyty Naukowe, 32: 3 – 18.
- Weiss, K. (1967 a). Influence of grafting conditions on acceptance of queen cells. Inker frennd, 22 (5): 144 – 148.
- Weiss, K. (1967 b). Influence of different types of queen-cell cups on acceptance and queen weight in artificial queen rearing. Z. Bieneforsch, 9 (3): 121 – 134.
- Zohairy A. M. (2001). Studies on queen rearing using cell punch and new other methods on *Apis mellifera*, L. M.Sc. Thesis, Fac. Agric. Mansoura Univ., Egypt , 148P.

جهاز وطريقة جديدة لتربية الملكات باستخدام (قفص نصف كرة بحاجز ملكات) في وجود الملكة .

أحمد محمود أبو النجا ١ ، عبد البديع عبد الحميد غانم ١ ، محمود السيد النجار ٢ ، أحمد محمد زهيري ٣

(١) جامعة المنصورة - كلية الزراعة - قسم الحشرات الاقتصادية .

(٢) مركز البحوث الزراعية - وزارة الزراعة .

(٣) قسم بحوث النحل - معهد بحوث وقاية النباتات - وزارة الزراعة .

أجري هذا البحث في منحل بقرية جديدة المنزلة - المنزلة دقهلية خلال عامي ٢٠٠٢ ، ٢٠٠٣ مع وضع الكؤوس المطعومة على قرص يرقات لدراسة نسبة القبول ووزن الملكات حديثة القفص كالاتي :-

(أ) في عام (٢٠٠٢) تقييم هذا القفص الجديد على اليرقات المطعومة داخل :-

{ أ } طوائف ممتازة بها ظاهرة (الإحلال) في وجود الملكة .

{ ب } طوائف ممتازة بها ظاهرة (التطريد) في وجود الملكة .

{ ج } طوائف (يتيمة) .

{ د } طوائف ممتازة تختار (عشوانيا) من المنحل في وجود الملكة .

كانت الطرق الثلاثة الأولى (٩٨,٣٢ % - ٩٨,٣٢ % - ٩٦,٦٥ %) على الترتيب أفضل من

العشوانيا (٧٨,٣٠ %) في نسبة القبول - أما وزن الملكات حديثة القفص فكانت (الإحلال) و (يتيمة)

و (عشوانيا) (١٦٢,٣١ - ١٦١,٠٨ - ١٦١,٤٩ مليون جرام) على الترتيب أفضل من (التطريد) (١٥٩,٦٤

مليون جرام) ويوجد فرق معنوي بينهم .

(ب) في عام (٢٠٠٣) تقييم هذا القفص الجديد على اليرقات المطعومة داخل :-

{ أ } طوائف ممتازة بها ظاهرة (الإحلال) في وجود الملكة .

- { ب } طوائف ممتازة بها ظاهرة (التطريد) في وجود الملكة .
{ ج } طوائف (يتيمة) .
{ د } طوائف ممتازة تختار (عشوائياً) من المنحل في وجود الملكة .
كانت الطرق الثلاثة الأولى (٩٨,٣٢ % - ٩٦,٦٦ % - ٩٥,٩٨ %) على الترتيب أفضل من العشوائي (٧٥,٦٤ %) في نسبة القبول - أما وزن الملكات حديثة الفقس فكانت الأفضل (الإحلال ١٦٢,٩٩ مليجرام) ثم (العشوائي ١٦١,٢٣ مليجرام) ثم (اليتيمة ١٦٠,٤٩ مليجرام) وأخيراً (التطريد ١٥٩,٦٦ مليجرام) .
{ ج } متوسط العاميين (٢٠٠٢ - ٢٠٠٣) تقييم هذا القفص الجديد على البرقات المطعومة داخل:-
{ أ } طوائف ممتازة بها ظاهرة (الإحلال) في وجود الملكة .
{ ب } طوائف ممتازة بها ظاهرة (التطريد) في وجود الملكة .
{ ج } طوائف (يتيمة) .
{ د } طوائف ممتازة تختار (عشوائياً) من المنحل في وجود الملكة .
كانت الطرق الثلاثة الأولى (٩٨,٢٢ % - ٩٧,٤٨ % - ٩٥,٨١ %) على الترتيب أفضل من العشوائي (٧٦,٩٦ %) في نسبة القبول - أما وزن الملكات حديثة الفقس فكانت الأفضل (الإحلال ١٦٢,٥٤ مليجرام) ثم (العشوائي ١٦١,٣٦ مليجرام) ثم (اليتيمة ١٦٠,٨٢ مليجرام) وأخيراً (التطريد ١٥٩,٦٥ مليجرام) .
{ د } تأثير طريقة التطعيم العادية (طريقة دوليتيل) وطريقة زهيري (جهاز جنتر المعدل) باستخدام هذا القفص الجديد على نسبة القبول ووزن الملكات حديثة الفقس:-
أوضحت النتائج أن طريقة زهيري (٩٩,١٠ %) كانت أفضل في نسبة القبول من طريقة دوليتيل (٨٩,٢٩ %) - أما وزن الملكات حديثة الفقس فكانت طريقة زهيري أيضاً (١٦٢,٧٥ مليجرام) أفضل من طريقة دوليتيل (١٦٠,٨٠ مليجرام) .
يوصى باستخدام هذا القفص الجديد مع طريقة زهيري للتربية داخل الطوائف القوية بالمنحل بمعدل ١٥ كاس ملكي لكل طائفة وكذلك الاستفادة من بيوت الإحلال الممتازة والتفقيص عليها بهذا القفص .