

## DEVELOPMENT OF A SEED DRILL FEEDING DEVICE TO SUIT PLANTING IN HILLS

M. K. Afify<sup>†</sup>

### ABSTRACT

*Field experiments were carried out to develop the fluted feeding device of seed drill equipment to accommodate the planting of seeds in hills especially the medical and aromatic seeds and that which favored by abundant branches such as Nigella sativa " black seed " seed under study. The evaluation of developed seed drill is carried out through the terms of four forward speed [3.13, 3.54, 4.28 and 4.85 km/h ] and four distances between hills [zero(before development), 15, 30 and 45 cm (after development)] and constant distance between rows of 40 cm. The evaluation of the developed seed drill was investigated through the plant characteristics as follows; germination period, germination ratio, The stem length, number of branches per plant, plant population per square meter, number of capsules per plant, weight of seed per plant, and total seed yield for each treatment. The field capacity, field efficiency, power, energy, and production cost were taken into consideration. The results concluded that the optimum distance between hills was 30 cm to achieve higher seed yield of 815 kg/fed, lower energy of 7.24 kW.fed/ton, production cost of 26.44 L.E/ton and higher germination ratio of 95.37 % with higher field efficiency of 89.41% at forward speed of 3.13 km/h .so the results recommended using the distance between hills of 30 cm and ranged forward speed of 3.13~ 3.54 km/h.*

### INTRODUCTION

**I**n Egypt, medicinal and aromatic plants represent a significant source of national income. They have an economic value for local and exterior markets. The cultivated area reached about 70000 feddans, mostly 80% concentrated in Upper Egypt governorates. They have a high export value in the first class from where the ratio of the production to the export and occupied the third class after cotton and rice in export operations. Egypt exported quantity attained about 85% from dry herbs, seeds, fruits, and flowers, and about 98% from aromatic oils and

---

<sup>†</sup>Ass. Prof. of Agric. Eng. Dept., Fac. of Agric., Zagazig Univ.

masticates from the total production area (Ministry of Agric, 2007). Although the importance of these plants as mentioned. They have still suffer a high inattention in all agricultural operations from planting to gathering. Seed planting with good methods, uniformity of distribution and seed covering are considered one means to get a better and high yield. **Abo El-Ees (1985)** showed that the method of seed drilling is very effective as well due to its effect on uniformity of depth and spacing. It is well known that mechanical seed drilling leads to more uniform spacing and sowing depth resulting in higher yield than the traditional hand method of sowing. **El-Shafy (1986)** found that using seed drill for sowing onion seed gave high production than other sowing methods (manual seed broadcasting, manual sowing in rows, self propelled machine and planter). **Dickey and Jasa (1989)** stated that the seed drills need a lot of skill in operation. It is necessary in case of automatic seed drills to calibrate them before sowing to know the exact seed rate it will drop. The seed drills are to be calibrated for each type of crop separately because of differences in shape, size and weight of different seeds. Proper care has to be taken in choosing the soil working part such as the tine. **Khan and El-Sahrigi (1990)** reported that the direct seeding in rows does not only save transplanting labor but also facilitate mechanical weeding, plant protecting operations and efforts. They showed that Egypt still need to develop simple row seeders for direct seeding for paddy under wet and dry field conditions. **Nour (1990)** studied the suitable method of planting rice under Egyptian conditions and to maximize profit. He concluded that planting rice with seed drill is accompanied by the lowest percentage of loss because of the uniform distribution of plants in both vertical and horizontal directions followed by mechanical transplanting and manual planting methods respectively. **Parish et al. (1991)** stated that the uniformity of seed spacing is an important factor in designing the pneumatic seed metering device. Besides the design of metering system, field and operational parameters affect the precision distribution of seeds. **Gupta and Herwanto (1992)** designed and developed a direct paddy seeder to match a two-wheel tractor. The machine had a field capacity of about 0.5 ha / h at a forward speed of 0.81m/s. Damage due to the metering mechanism

was nil for soaked seeds and 3% for pre germinated seeds. **Abdou (1995)** investigated different planting methods to recommended the most profitable system. He concluded that the using of seed drill gave the highest seed seedling compared with two row planter. **Panning et al. (2000)** demonstrated that the seed spaces are important for crops such as sugar beet, because seed space uniformity is significant factor affecting production costs and total yield although there are many planters having different seed metering and are not capable of operating at high travel speed in the same time. **Gamal et al. (2001)** found that canola sowing by seed drill with suitable row width of 40 cm gave the highest yield and the lowest energy consumption as compared with manual planting and planter. **Bangboye and Mofolasayo (2006)** evaluated a manually operated two-row okra planter for performance by conducting field and laboratory tests. They conducted that the percentage difference between the weights of seeds discharged from the two hoppers of 4.97% at seed rate of 0.36kg/hr and the percentage damage of 3.51% was attained with spacing of 70cm and average depth between 8mm and 9mm. The overall average efficiency of the planter was 71.75%. **Rao et al. ( 2007 )** stated that in Europe, Australia and united states encourage rice direct seeding owing to facility applied mechanization, and the risk of yield due to weeds competition can be decreased as the result of size differential between rice plants and weeds, and from the other side to the suppressive effect of standing water on weed growth. **Ibrahim et al. (2008)** developed the feeding device of seed drill for planting the soaked and hasted seed rice in rows. The results showed that decreasing the weed plants in square meter and increasing the germination percentage by 97% at forward speed of 0.64 m/s. The objectives of this study are to develop seed drill feeding device to be suitable for Black seed planting and optimize some operating parameters affecting the performance of the developed machine.

### **MATERIALS AND METHODS**

Field experiments were carried out to develop the fluted feeding device of seed drill equipment to accommodate the planting of seed in hills especially the medical and aromatic seed and that which favored by abundant branches such as *Nigella sativa* " black seed " seed under study and other seed closed in physical characteristics. The " black seed " seed were cultivated in a

private farm in Adlia village –Belbis district – Sharkia governorate in the last week of September 2006 and harvested in April 2007

**1 - MATERIALS:**

- **Seed drill:** A seed drill of dimensions 135 L × 110 W × 150 H cm<sup>3</sup> planted in row provided with five tubes transfer the seed from the hopper across a feeding device to the ground. Distance between tubes rows is about 20 cm.
- **Tractor:** Fiat model, made in Italy, four cylinder, and power of 22 kW.
- **Electric motor :** made in Italy. 100 rpm and power of 0.18 kW.
- **Electric balance:** of 0.01 g as accuracy to measure the mass of seed.

▪ **METHODS:**

The seed mechanical properties were measured using the following equations (El-Raie *et al.* 1996) and studied by ( Afify *et al.*, 2007 ) as shown in **Table ( 1 )**.

$$V = \frac{\pi}{6}(L.W.T), \text{ mm}^3 \quad \dots\dots\dots(1)$$

$$S = \frac{3\sqrt{L.W.T}}{L} \times 100, \% \quad \dots\dots\dots(2)$$

$$D_g = 3\sqrt{L.W.T}, \text{ mm} \quad \dots\dots\dots(3)$$

$$D_a = \frac{(L+W+T)}{3}, \text{ mm} \quad \dots\dots\dots(4)$$

$$A_f = \frac{\pi}{4} L.W, \text{ mm}^2 \quad \dots\dots\dots(5)$$

$$A_t = \frac{\pi}{4} \frac{(L+W+T)^2}{3}, \text{ mm}^2 \quad \dots\dots\dots(6)$$

**The developed seed drill** : The prototype, elevation and side view of the machine after development is shown in **Fig. (1, 2, and 3)**. This seed drill was developed taking into consideration the following criteria;

- 1- Cultivate " black seed " seed in hills to reduce thinning a rate, prevent the crowded and reticulation of plants branches during the different growth phases, ease of operation and consequently get needs of light and CO<sub>2</sub>.
- 2- Choice of materials for the developed machine to reduce the total energy requirements to make the machine affordable and within the capacity of the local farmers

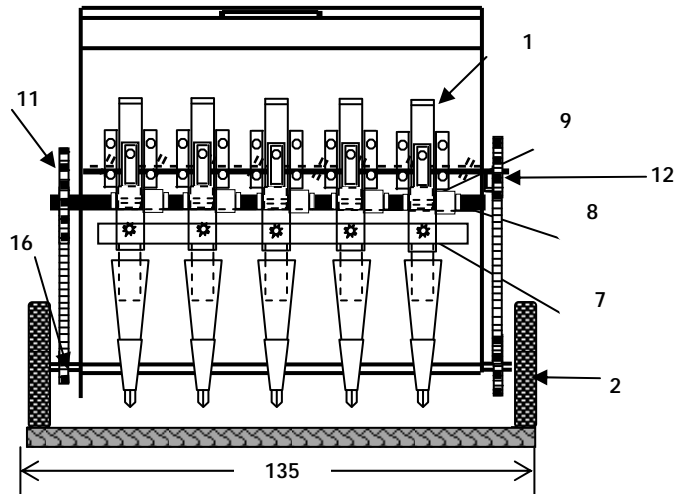

Fig.(1):Elevation view of the developed seed drill

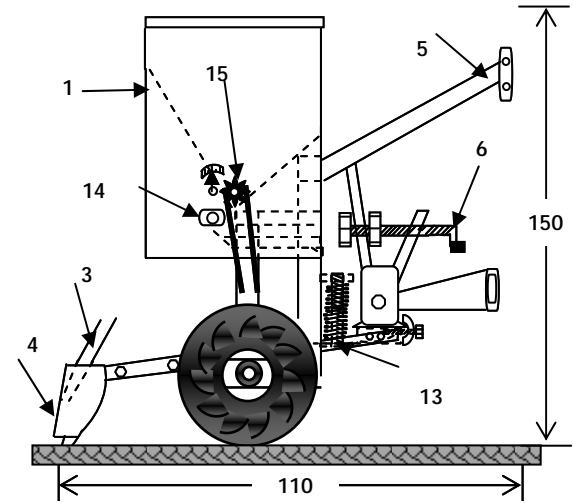

Fig.(2):Side view of the developed seed drill

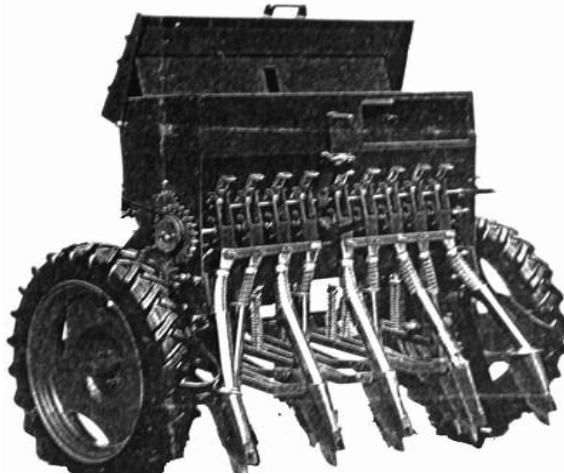

Fig.(3): The prototype of developed seed drill

No.	Name	No.	Name
1	Seed hopper	9	Feeding gear
2	Ground wheel	10	Feeding inhibitor
3	Seed tubes	11	Feeding gear
4	Furrow openers	12	Agitator gear
5	Hitching point	13	springs
6	Depth control adjust.	14	Feeding shaft
7	Joint screws	15	Agitator shaft
8	Feeding area adjust.	16	Ground wheel gear
DIM IN CM		Scale 1:20	

**Table (1) : The mean geometric properties of 'black seed' seed.**

<b>Geometric and mechanical properties</b>	<b>Value</b>	<b>Unit</b>
Av. Length ( L )	3.02	mm
Av. Width ( W )	1.28	mm
Av. Thickness ( T )	0.8	mm
Av. Volume ( V )	1.63	mm <sup>3</sup>
Av. Geometric diameter ( D <sub>g</sub> )	1.47	mm
Av. Arithmetic diameter ( D <sub>a</sub> )	1.62	mm
Av. Flat surface area (A <sub>f</sub> )	3.03	mm <sup>2</sup>
Av. Sphericity ( S )	48.22	%
Av. Transverse surface area of the individual seed ( A <sub>t</sub> )	0.80	mm <sup>2</sup>
Av. Coefficient of friction (Seed/metal)	0.85	

**A- The development of feeding system:**

The feeding shaft of 100 cm length and 2.54 cm diameter was fabricated and constructed the following developed parts:

**1- Feeding gear :** The feeding device of the present seed drill from the fluted type as a gear shape of 6 cm diameter and 5 cm width with 12 teeth on its circumference and did not gave space between seed in the same row. The same diameter of 6 cm of developed gear with 4 teeth distributed on total circumference with angles of 90° was fabricated and constructed as shown in **Fig. ( 4 ) part no. 5**.The developed gear gives the chance to make a distance between the seed and put the seed in hills in the same row according to the desired design and plants conditions.

**2 - Feeding sleeve :** It made of inflexible compact plastic as shown in **Fig. (4 ) part no. 6** with circular shape and the same dimensions of gear feed to control the passing seed from hopper.

**3 - Washer retaining :** Two washer retaining of circular shape of 4 cm diameter and 1 cm width was constructed before the feeding gear and after the seed sleeve as shown in **Fig. (4 ) part no. 4** to prevent the motion and assembly .The washer was fixed by screw nut.

**4-vertical feeding inhibitor (seed cup lock):** It was fabricated and constructed by screw on the front side of the hopper as shown in **Fig. (4) part no. (2)** to slide in duct to make as a gate to close any undesired unit to control the distance between plants in beside rows. This unit worked easily by moving up and down by screw.

## **B- Laboratory seed metering:**

**1 – An electric motor** of 0.25 hp was fixed on the frame of hopper by fixed elements of iron bar and screw. A pulley of 10 cm dia. was attached to the axis of motor to represent the same diameter of a sprocket equipped on the ground wheel. Three pulleys of 5 cm, 10 cm and 15 cm dia. were equipped on the feeding shaft to represent the three sprocket attached to the feeding shaft. This procedure was done for metering the seed drill laboratory.

**2-** A certain amount of recommended seed was put according to seed rate before and after development in seed tank.

**3-** The certain seed cup was locked by **vertical feeding inhibitor** to limit the distance between seeds in adjacent rows to be about 40 cm.

**4-** The **horizontal feeding sleeve** as shown in **Fig.(4) part no.8** was moved beside to lock the seed flow directly from hopper to tubes during calibration procedure. In the same time, the fallen seed forward to the tray.

**5-** A tray of 1 m length and 35 cm width and side wall of 12 cm as shown in **Fig. (4) part no.10** was constructed below the seed hopper and bolted in the main frame to gather the seed against the rotations times for the motor pulley as a ground wheel.

**6-** The covered area and the amount of seeds were calculated and the sowing rate was calculated according to the following formula;

**Sowing rate** = seed weight, (kg) /tested area (fed.)...(kg/fed)..... (7)

## **C- The development of transmission system as following described:**

**1 – Ground wheel :** the seed drill was provided with a ground wheel of 63 cm diameter as shown in **Fig. (5)** . This wheel was replaced by ground wheel of 40 cm diameter to achieve the development requirements.

**2- Transmission system :** the left ground wheel was provided by sprocket of 10 cm diameter and transmit the motion to the feeding shaft through 3 sprocket of 5, 10, and 15 cm diameter by chains to gave a distance between seed in the same row of 15, 30, and 54 cm respectively to select the optimum distance between seed as shown in **Fig. (5)**. On the other hand, The right ground wheel was provided by sprocket of 10 cm diameter and transmit the motion to the agitator shaft by chain.

## **CALCULATIONS:**

**1- Plants characteristics:** some characters were measured during the different periods of growth as; average stem length (cm ), average number

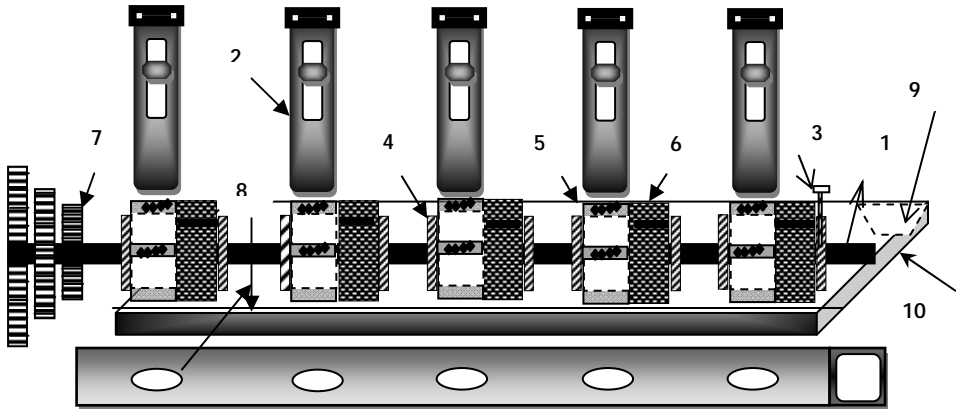

No.	Name	No.	Name
1	feeding shaft	6	Feeding sleeve
2	Seed cup lock	7	Feeding gear speed
3	Screw nut	8	Seed openings lock
4	Washer retaining	9	Metering discharge gate
5	Developed gear	10	Metering tray

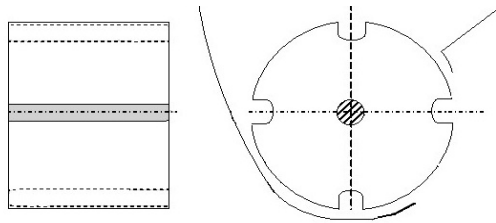

**Fig.( 4 ):The arrangement of developed feeding device**

No.	Name
1	Agitator shaft
2	Chain
3	Seed feeding shaft
4	Feeding shaft sprocket
5	Ground wheel sprocket
<b>Dim IN Cm</b>	

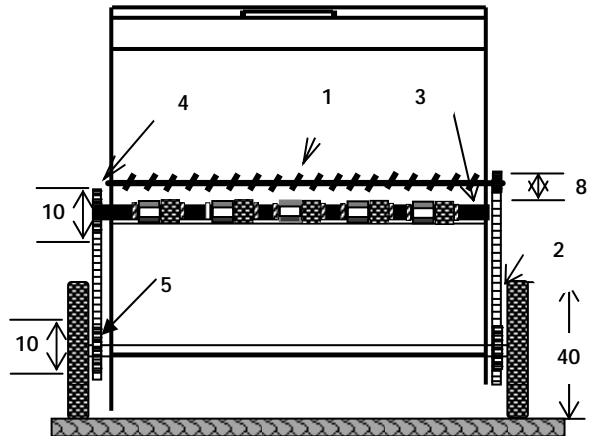

**Fig. ( 5 ): The transmission system of the developed seed drill**



of branches per plant, average plant population per square meter, average number of capsules per plant, average weight of seed per plant, and average total seed yield ( ton / fed.) for each treatment.

**2- Germination ratio :** a sample of 100 seed was germinated and replicated three times before planting.

**3- Uniformity of plant distribution:** It was measured after 16 days at two directions from lateral to longitudinal by using a wooden frame (80 x 80 cm) divided in two directions at equal distance (5x5cm).The deviation of plant from average number of plant at standard area was estimated according to the following equation;

$$C.V = [\sigma_n] / [\bar{X}] \times 100 \dots\dots\dots(8)$$

Where:

**C.V :** coefficient of variation in the longitudinal and lateral direction from average number of plants at a standard unit area

$\bar{X}$  : average number of plant at standard unit area.

$\sigma_n$  : Standard deviation.

$$\sigma_n = \sqrt{\frac{\sum \langle X - \bar{X} \rangle^2}{n - 1}} \dots\dots\dots(9)$$

Where:

$\Sigma X$  : Summation of the number of plants on the longitudinal or lateral direction.

$\Sigma X^{-2}$  : Summation of the square number of plants on the longitudinal or lateral direction.

n : Number of readings.

The coefficient of variation under 10% is considered excellent and with value under 20 % is generally considered acceptable for most field applications as reported by **Coates (1992)**.

**4- Theoretical field capacity:** It was determined using the following formula:  $P_{th} = S \times W / 4200$  (fed/h).....( 10 )

Where:

$P_{th}$  : Theoretical productivity of the machine, fed/h.

$S$  : travel speed, m/h.

$W$  :Rated width, m.

**5- Effective field capacity:** It was determined by using the following formula:  $P_{act} = 60 / Tu + Ti$  fed/h.....( 11 )



### • **TESTING AND EVALUATION:**

The soil was plowed twice by chisel plough and leveled by land lever. The seed mixed with sand at rate 1:1 with seed rate of 2 kg / feddans using the traditional seed drill according to recommendation of (**Ministry of Agriculture, Horticulture Research Institute, Medicinal and Aromatic Plants department, 2005**) and seed rate of 1, 0.75, and 0.50 kg / feddans for the developed seed drill without sand to suit the distances under study. Tests were conducted on the machine to ascertain its performance. The 'black seed' seed (*nigella sativa*) were cultivated at distance between rows of 40 cm under four tested distance between the seed in the same row [zero(before development), 15, 30, and 45 cm (after development)] by changing the speed ratio between the sprocket on the ground wheel and three sprockets on feeding shaft. Four forward speeds of 3.13, 3.54, 4.28, and 4.85 km / h for the seed drill were tested. Mean of the three readings resulting in a total of 48 observations (4 distance between seed in the row × 4 forward speeds × 3 observations) were taken and a split block design in Randomized Complete Block Design was used with these observations.

### **RESULTS AND DISCUSSIONS**

The performance of developed seed drill was discussed through the following criteria

- 1. Emergence period** : The results in **Fig. (6A)** showed that increasing the forward speed of developed seed drill from 3.13 to 4.85 km/h decreased the emergence period by 23.08, 30, 25, and 37 % under the distance between seed of Zero, 15, 30, and 45 cm respectively. Also increasing the distances between seeds from zero to 45 cm decreased also the emergence period by 38.46, 41.67, 54.55, and 50 % under the forward speed of 3.13, 3.54, 4.28, and 4.85 km/h respectively. The reduction in emergence period is due to decrease the fallen seed number and depth regularity as increasing both the forward speed and distance between seed
- 2. Emergence ratio** : Data shown in **Fig. (6B)** demonstrated increasing the forward speed of developed seed drill from 3.13 to 4.85 km/h decreased the emergence ratio by 13.26, 6.86, 6.42 and 5.71% under the distances between seeds of zero, 15, 30, and 45 cm respectively. That may be due to the fracture of the seed in feeder. But increasing the

distance between seed from zero to 45 cm increased also the emergence ratio by 37.74, 43.57, 47.04 and 49.73 % under the forward speeds of 3.13, 3.54, 4.28, and 4.85 km/h respectively. That is due to reduce the competition between seed resulting from low seed number in hills and depth regularity.

**3. Stem length** : Given data in **Fig. (6C)** showed that increasing the forward speed of developed seed drill from 3.13 to 4.85 km/h decreased the stem length by 3.13, 5.62, 5.59 and 5.63 % under the distances between seeds of zero, 15, 30, and 45 cm respectively Also, increasing the distance between seed from zero to 45 cm decreased also the stem length by 16.56, 18.59, 19.38 and 18.72 % under the forward speeds of 3.13, 3.54, 4.28, and 4.85 km/h respectively. That is attributed to increase the seed number in hills and reduce the distance between plants encourage the crowded plant to forward increasing the stem to get needs of air and light and vise versa to the low seed number and low forward speed.

**4. Number of branches per plant** : Increasing the forward speed of developed seed drill from 3.13 to 4.85 km/h as shown in **Fig. (6D)** decreased the number of branches per plant by 21.34, 13.05, 16.62 and 15.70 % under the distances between seeds of zero, 15, 30, and 45 cm respectively. That is due to reduce the emergence ratio as increasing the forward speed and fracture seed in feeder. On the other hand, increasing the distance between seed from zero to 45 cm increased the number of branches per plant by 110.74, 121.64, 122.40 and 125.83 % under the forward speeds of 3.13, 3.54, 4.28, and 4.85 km/h respectively. That is due to increase the emergence ratio and reduce emergence periods as increasing the distance between plants in the same row.

**5. Uniformity of distribution** : It decreased by 9.84, 7.90, 9.66 and 10.59 % under the distances between seeds of Zero, 15, 30, and 45 cm respectively as increasing the forward speed of developed seed drill from 3.13 to 4.85 km/h. That is due to depth irregularity as increase the forward speed. While increasing the distance between seed from zero to 45 cm as shown in **Fig. (6E)** increased the uniformity distribution by 30.09, 30.63, 27.99 and 29 % under the forward speed of 3.13, 3.54, 4.28, and 4.85 km/h respectively. That is due to depth regularity

**6. Grain scattering** : The vise versa of uniformity distribution was done

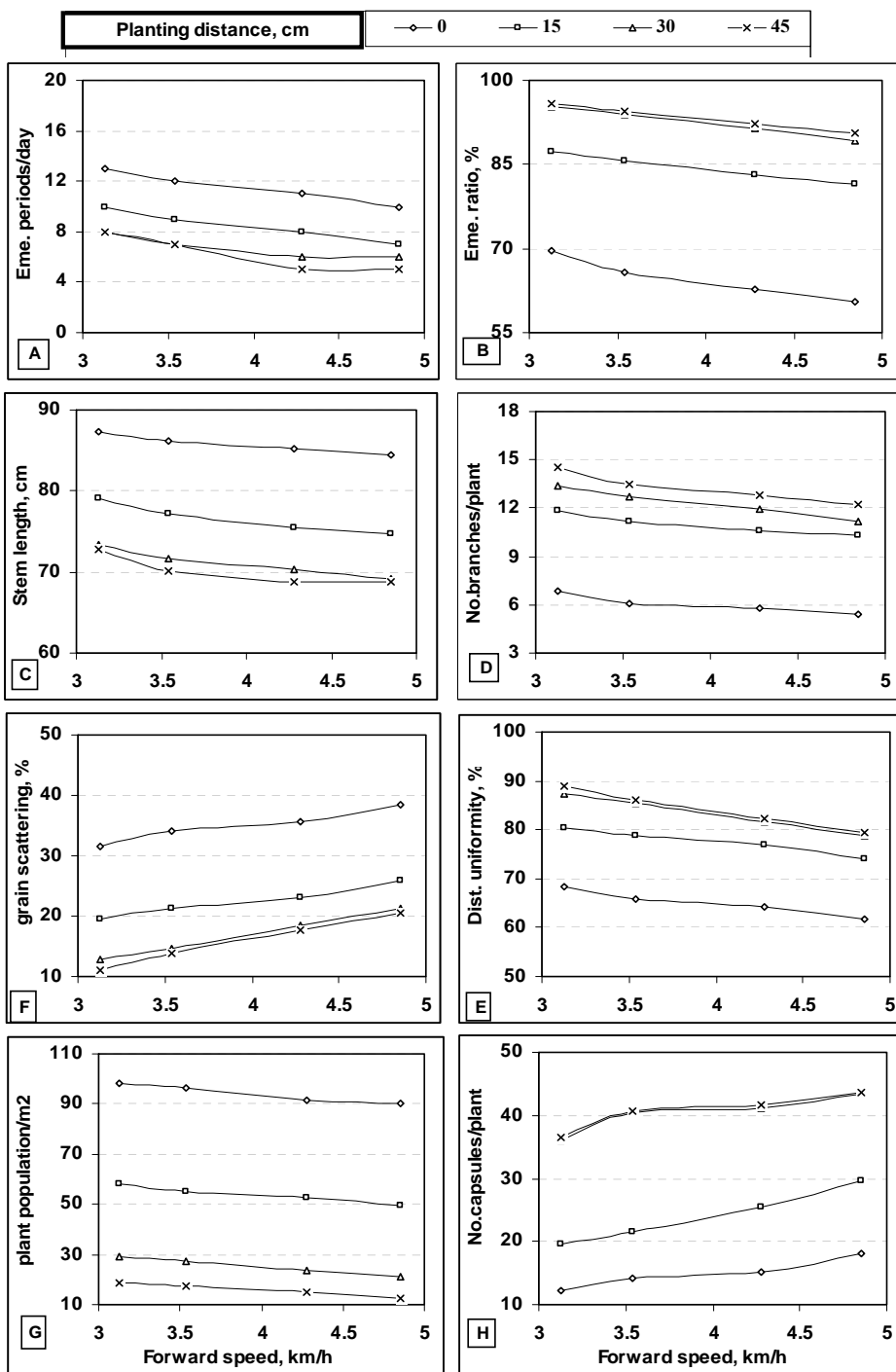

**Fig. (6): Effect of the distance between plants and forward speed of developed seed drill on some physical characteristics of ' black seed' plants.**

with grain scattering as shown in **Fig. (6F)**. It noticed that increasing the forward speed of developed seed drill from 3.13 to 4.85 km/h increased the grain scattering by 21.26, 32.69, 65.88 and 85.08 % under the distances between seeds of zero, 15, 30, and 45 cm respectively. While increasing the distance between seed from zero to 45 cm decreased also the grain scattering by 65.01, 59.22, 50.36 and 46.60 % under the forward speeds of 3.13, 3.54, 4.28, and 4.85 km/h respectively.

**7. Plant populations per square meter**: Increasing the forward speed of developed seed drill from 3.13 to 4.85 km/h decreased the plant populations per square meter by 8.35, 14.23, 27.57 and 32.32 % under the distances between seeds of zero, 15, 30, and 45 cm respectively. That is due to low germination ratio. Also increasing the distance between seed from zero to 45 cm decreased the plant populations per square meter as illustrated in **Fig. (6G)** by 80.99, 82.16, 83.96 and 85.96 % under the forward speeds of 3.13, 3.54, 4.28, and 4.85 km/h respectively. That is due to the limited seed rate for each treatment

**8. No. of capsules per plant** : Data illustrated in **Fig. (6H)** showed that increasing the forward speed of developed seed drill from 3.13 to 4.85 km/h increased the number of capsules per plant by 50.21, 52, 20 and 19.45 % under the distances between seeds of Zero, 15, 30, and 45 cm respectively. Also increasing the distance between seed from zero to 45 cm increased also the number of capsules per plant by 201.73, 186.32, 174.13 and 139.96 % under the forward speeds of 3.13, 3.54, 4.28, and 4.85 km/h respectively. That is due to low emergence period and stem length that help the plant to exist increasing number of capsules quickly.

**9. Weight of seed per plant** : The weight of seed per plant increased by 5.17, 11.35, 18.20 and 19.60 % as increasing the forward speed of developed seed drill from 3.13 to 4.85 km/h under the distances between seeds of zero, 15, 30, and 45 cm respectively as demonstrated in **Fig. (6I)**. Also, increasing the distance between seed from zero to 45 cm increased the weight of seed per plant by 600, 594.68, 634.40 and 696.05 % under the forward speeds of 3.13, 3.54, 4.28, and 4.85 km/h respectively. This increase is attributed to the increase in capsules number

**10. Seed yield** : Increasing the forward speed of developed seed drill from 3.13 to 4.85 km/h decreased the seed yield by 3.61, 4.50, 14.40 and

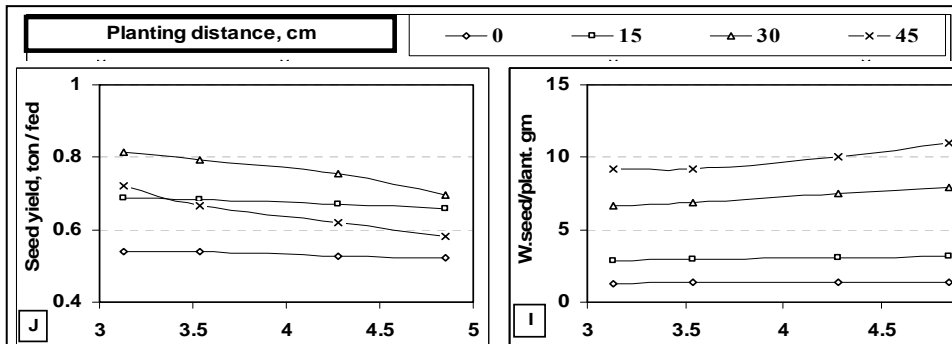

**Fig. (6)cont.:** Effect of the distance between plants and forward speed of developed seed drill on some physical characteristics of ' black seed' plants.

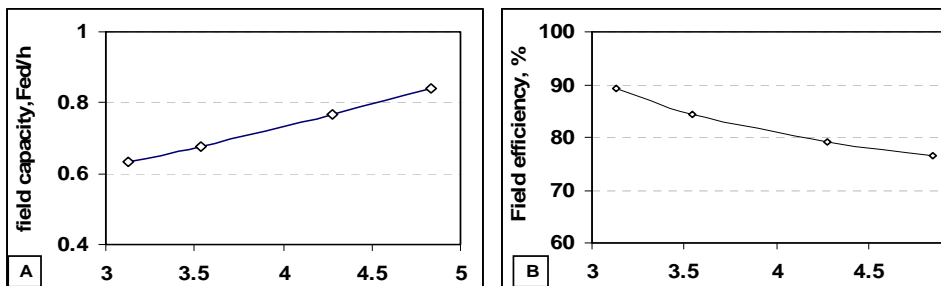

**Fig. (7):** Effect of the distance between plants and forward speed of developed seed drill on effective field capacity and field efficiency.

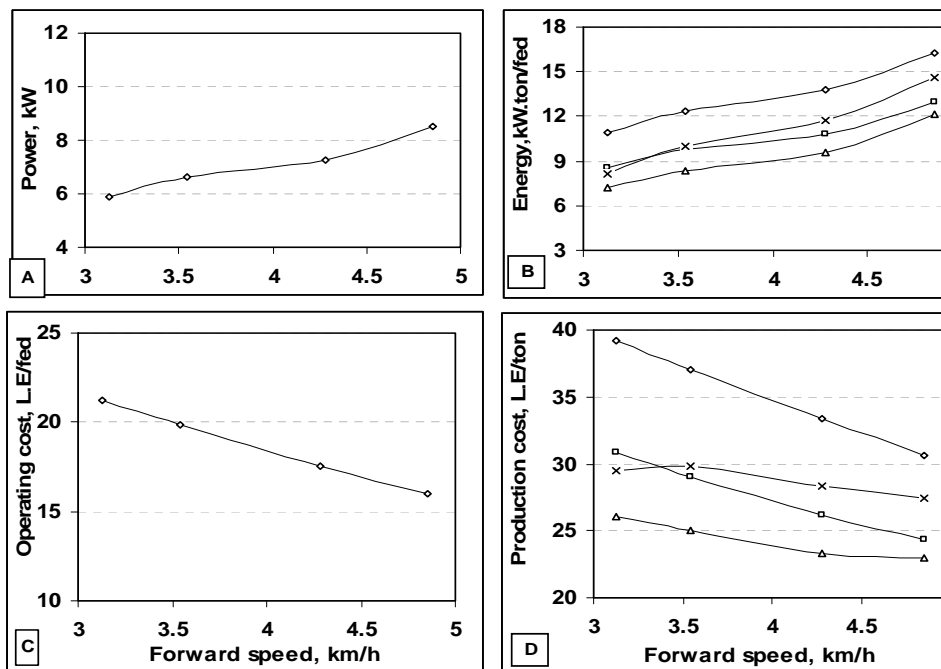

**Fig. (8):** Effect of the distance between plants and forward speed of developed seed drill on energy requirement production cost

19.05 % under the distances between seeds of zero, 15, 30, and 45 cm respectively as illustrated in **Fig. (6J)** . That is due to low plant number. While increasing the distance between seed from zero to 45 cm increased the seed yield by 33.07, 23.91, 17.83 and 11.75 % under the forward speeds of 3.13, 3.54, 4.28, and 4.85 km/h respectively. That is due to the increase in seed weight in plant

**11. Effective field capacity and Field efficiency:** Data in **Fig. (7A and B)** showed that increasing the forward speed of developed seed drill from 3.13 to 4.85 km/h increased the effective field capacity by 32.70 % . While decreasing the field efficiency by 14.35 % under the different distances between seeds in the same row where there is no effect the distance between plant in row was remarked

**12. Power and energy requirements:** Refereeing to **Fig. (8A)**.it is noticed that increasing the forward speed of developed seed drill from 3.13 to 4.85 km/h increased the required power by 44 % under the different distances between seeds the same row . On the other hand, The energy requirements increased by 49.46, 50.86, 68.29 and 77.98 % as increasing the forward speed of developed seed drill from 3.13 to 4.85 km/h under the distances between seeds of zero, 15, 30, and 45 cm respectively. That is due to the decrease the seed yield as illustrated in **Fig.(8B)**. While decreasing by 24.85, 19.30, 15.13 and 10.52 % as increasing the distance between seed from zero to 45 cm under the forward speeds of 3.13, 3.54, 4.28, and 4.85 km/h respectively. That is due to the increase in seed yield

**13. Operating and production cost:** Notifying to **Fig. (8C)** it is remarked that increasing the forward speed of developed seed drill from 3.13 to 4.85 km/h decreased the operating cost by 24.64 % under the different distances between seeds the same row . That is due to the increase in effective field capacity as increasing the forward speed. The obtained data in **Fig. (8D)** viewed that increasing the forward speed of developed seed drill from 3.13 to 4.85 km/h decreased the production cost by 21.82, 21.09, 11.97 and 6.91 % under the distances between seeds of zero, 15, 30, and 45 cm respectively. That is due to the decrease the operating cost vise versa the forward speed. But increasing the distance between seed from zero to 45 cm decreased the Production cost by 24.85,



19.30, 15.13 and 10.52 % under the forward speeds of 3.13, 3.54, 4.28, and 4.85 km/h respectively. That is due to the increase in seed yield

### CONCLUSION

This study aimed to develop the fluted feeding device of seed drill equipment to accommodate the planting of seed in hills especially the medical and aromatic seeds which favored by abundant branches such as "black seed " seed. The results concluded that the optimum distance between hills was 30 cm to achieve higher seed yield, lower energy, lower production cost and higher germination ratio with higher field efficiency at forward speed of 3.13 km/h .so the results recommended using the distance between hills of 30 cm and ranged forward speed of 3.13~ 3.54 km/h although of raising the cost per ton slightly at this range but compensate that the high raising in seed yield and money value for medical seeds.

### REFERENCES

**Abo El-Ees, N. A. (1985).**The effect of seed-bed preparation and method of planting on crop yield. Misr J. Agric. Eng. Vol.2 NO. (4): 131 – 136.

**Adbou, F. M. (1995).** Design of a combination unit for cultivating, ridging, and spraying pesticide and fertilizer. Misr J. Agric. Eng. Vol. 12 No. (3): 601-623.

**Afify, M. K., M. M. A. El-Sharabasy, and M. M. A. Ali (2007)** Development of a local threshing machine suits for threshing black seed (*nigella sativa*). Misr J. Agric. Eng. Vol. 24 No. (4): 699-724.

**Awady, M. N; E.Y. Ghoniem, and A. I. Hashish (1982):** Agriculture comparison between wheat combine harvesters under Egyptian conditions. Res.Bul.Ain-Shams Univ.:13p.

**Bamgboye, A. and A. Mofolasayo(2006).** Performance evaluation of a two-row okra planter. Agricultural Engineering International: the CIGR journal. Manuscript PM 06 002. Vol. VIII. July.

**Barger, E. L; R. A. Kepner and R. Bainer (1982):** Principles of farm machinery. Willey and Sons Inc.New York.

**Coates, W. (1992)** Performance evaluation of a pendulum spreader. Trans. ASAE, 8 (3): 285 – 288.

**Dickey, E.C. and P. Jasa (1989).** Row Crop Planters: Equipment Adjustments and Performance in Conservation Tillage. NebGuide G83-684, University of Nebraska Cooperative Extension, Lincoln, NE 68583.

**El-Raie, A. E. S; N. A. Hendawy and A. Z. Taib (1996):** Study of physical and engineering properties for some agricultural products. *Misr. J. Agric. Eng.* 13(1): 211-226.

**El-Shafy, M. W. (1986)** Mechanization of onion and pulps production. Report ( In Arabic ) *Agric. Eng. Res. Inst.*, p: 30- 40.

**Gamal, H. E.; M. A. El-Attar; S. E. Bader and I. Yahia(2001).** Effect of mechanical planting system on Canola crop yield. *Misr J. Agric. Eng.* Vol.18 NO. (4): 163 – 172.

**Gupta, C. P. and Totok Herwanto(1992).** Design and development of a direct paddy seeder. *Agricultural Mechanization in Asia, Africa and Latin America.* Vol. 23, No. 1, Pp. 23-27.

**Ibrahim, M.M.; H. N. Abd El-Mageed and T. H. Abd- Alla (2008).** Development and evaluation a small machine for soaked rice direct planting. *Misr J. Agric. Eng.* Vol. 25 No. (3): 655-676.

**Khan, A.U. and A.F. El-Sahrigi, (1990).** Selective mechanization of rice farming system in tropical Asia. *Agric. Eng. Today* 14(3,4): 40,52.

**Ministry of Agricultural and land reclamation (2007)** Economic affair sector, *Agricultural statistics crops.*

**Nour, H.M., (1990).**Evaluation of rice harvesting. Unpublished M.Sc. Thesis, Ag. Mech. Dept., Faculty of Agric., Mansoura Univ. Egypt.

**Panning, J. W.; M. F. Kocher; J. A. Smith and S. D. Kachman (2000).** Laboratory and field testing of seed spacing uniformity sugar beet planters. *Applied Engineering in Agriculture.* Vol (16) No. (5): 7 – 13.

**Parish, R. L.; P. E. Bergeron and R. R. Bracy (1991).** Comparison of vacuum and belt seeders for vegetables planting. *Applied Engineering in Agriculture.* Vol (7) No. (5): 537 – 540.

**Rao, A.N. ; D.E. Johnson ; B. Sivprasad ; J.K. Ladha and A.M. Mortimer (2007).**Weed management in direct-seeded rice. *Advances in Agronomy,* volume 93(2007): 152 - 255.

وزارة الزراعة واستصلاح الأراضي. مركز البحوث الزراعية . الإدارة المركزية للإرشاد الزراعي (2005) "خدمة وزراعة حبة البركة" . معهد بحوث البساتين – قسم بحوث النباتات الطبية والعطرية- نشرة رقم 984.

## الملخص العربي

### تطوير جهاز التغذية في آلة تسطير البذور لتناسب الزراعة في جور

أحمد خطاب عفيفي<sup>1</sup>

تحتاج النباتات الطبية والعطرية إلى خبرة في عمليات الزراعة لما تمثله بذورها من قيمة نقدية عالية سواء عند شراء التقاوي أو تصديرها أو دخولها في عمليات التصنيع المختلفة. وحتى الآن مازال جميع المزارعين يتجهون للزراعة اليدوية في زراعة بذور النباتات الطبية والقليل منهم يتجه لاستخدام آلة تسطير البذور لأن المشكلة التي تواجههم في استخدام آلة التسطير هو عمليات الخف المتتالية نتيجة التفريع العزير لهذه النباتات مما يشكل عقبة وتكلفة كبيرة والتي تضعف النبات وتجهده وتؤدي إلى موته وتقلل إنتاجه من البذور ولذلك يفضلون دائما الزراعة اليدوية بالرغم من ارتفاع معدل التقاوي للقدان لتجنب موت النباتات وحفاظا على التقاوي والإنتاج. ولذا كان الهدف من هذه الدراسة هو تطوير جهاز التغذية في آلة تسطير البذور بسيطة مكونة من خمس وحدات تغذية بما يضمن أقل معدل للتقليم وأعلى إنتاجية وأقل طاقة مستهلكة مع أقل تكاليف. وقد تم التطوير لعمود التلقيم وجهاز النقل ليشمل الآتي :

- 1) تطوير ترس التلقيم بقطر 6 سم ومزود بأربعة غرف موزعة على المحيط الكامل بزوايا 90°
  - 2) تركيب مانع للتقليم من البلاستيك المدمج الصلب ليقفل من خدش البذور.
  - 3) تزويد فتحات نزول البذور بالصندوق بحواجز رأسية لمنع نزول البذر لوحدة التغذية للتحكم في المسافة بين الصفوف بسهولة
  - 4) تزويد الآلة بحاجز أفقي يمنع نزول البذور للأنياب ويوجهها لصندوق تجميع لإجراءات المعايير المعملية.
  - 5) تركيب عجل للآلة بقطر 40 سم وتزويد عمود العجلة بمسنن قطر 10 سم وعمود التلقيم بثلاث مسننات قطر 5 ، 10 ، 15 سم للتحكم واختيار أفضل مسافة بين الجور على الصف.
- تم اختبار الآلة المطورة على أربعة سرعات أمامية (3.13 ، 3.54 ، 4.28 ، 4.85 كم/ساعة) وأربعة مسافات بين الجور (صفر (قبل التطوير) ، 15 ، 30 ، 45) (بعد التطوير) ومسافة بين الصفوف ثابتة (40 سم). وتم قياس المواصفات النباتية المختلفة للمحصول : فترة الإنبات ، نسبة الإنبات ، طول الساق ، عدد الفروع للنبات ، انتظامية التوزيع ، نسبة التشتت ، عدد الكبسولات للنبات ، عدد النباتات في المتر المربع ، وزن البذور للنبات ، المحصول الكلي للبذور . كما تم قياس السعة الحقلية والكفاءة الحقلية ، احتياجات القدرة والطاقة المستهلكة ، تكلفة إنتاج البذور .
- وقد أظهرت النتائج أن أفضل مسافة بين الجور لزراعة بذور حبة البركة باستخدام هذه الآلة كانت (30 سم) حيث تحقق عندها أعلى نسبة إنبات (95.37 %) أعلى إنتاجية للبذور (0.815 طن / فدان) وأقل طاقة مستهلكة (7.24 كيلوات.فدان/طن) وتكلفة إنتاج (26.44 جنيه/طن) ويوصى بمتوسط سرعة أمامية للآلة يتراوح من (3.13 ~ 3.54 كم/ساعة) لزيادة الإنتاج من البذور بمعدل عالي وارتفاع سعر الكيلو جرام من البذور مقارنة بالسرعات العالية التي ينخفض عندها إنتاج البذور بمعدل مرتفع وارتفاع التكلفة ضئيل جدا .

<sup>1</sup> أستاذ مساعد الهندسة الزراعية – كلية الزراعة – جامعة الزقازيق