

## **DESIGN AND FABRICATION OF A SIMPLIFIED MECHANICAL HANDLING SYSTEM OF RICE STRAW BALING OPERATION TO REDUCE ENVIRONMENT POLLUTION**

**El-Gindy, A. M.<sup>(1)</sup>, Baiomy, M. A.<sup>(2)</sup>, Abdelhamed, M. M.<sup>(3)</sup>**

**And Mosa, Sahar, A.<sup>(4)</sup>**

### **ABSTRACT**

*The burning of crop residues is one of national problems in Egypt especially after harvesting or threshing operations to the different crops. The main objective in the present study is: Design, fabricate and evaluate the mechanical system of threshing and handling rice straw directly to the baler. A conveyor belt was designed to transport the rice straw from threshing machine to the baler. Selections of all bearings of the mechanical system were done according to the load carrying capacity. Welding joints were checked against the stresses. The fuel consumption was measured for the system. The power requirement to operate the belt conveyor and baler was calculated. All power calculations were provided to indicate the size of tractor and evaluate the performance of the proposed system. Several experiments and tests were carried out at different speeds. The conveyor dimensions were determined to be 3000 mm length, 750 mm width and the height was variable to be adjusted opposite to the machine throw and the feeding of baler. The belt conveyor was covered with a canvas to reduce dust broadcasting.*

### **INTRODUCTION**

**I**n Egypt, there are about 1.6 millions feddans cultivated with rice each year (The Agricultural Magazine 2007). This produces about 4 to 5 million tones of rice straw. This quantity presents a sizable problem to the farmers, government and the environment. The output of the threshing operation contain different fine particles sizes, and several types of microorganisms, such as *Aspergillus niger*, *Penicillium*, *Yeasts*, *Alternaria*, *cladosparium* and *Mucor*

---

\*Prof., Agr. Eng. Dept., Faculty of agric. Ain Shams Unl.

\*\*Senior Researcher, Agric., Eng. Res. Inst., Agric. Res. Center.

\*\*\*Prof., Faculty Of Engineerng, Ain Shams Univ.

\*\*\*\*En., Agric., Eng. Res. Inst., Agric. Res. Center.

considered environmental pollution. (El-Gindy et al. 2005). In general dust particles, in the straw consist of finely divided solid particles, fine size suspended in the atmosphere and coarse size deposited on the plants and soil. The straw dust also pollutes the water at the rural areas, which has bad effect on human and animals' health. (El-Gindy et al. 2001). Farmers usually burn their straw yield at the end of the rice harvesting season for the fields be prepared for the next crop. Burning rice straw may increase the soil surface layer temperature, causing a sharp drop in winter crop seedling emergence. The frequent straw burning may cause subsoil hard pan, which makes the drainage difficult, restricts seedlings emergence (Agricultural magazine 1999). One tone of rice straw burning would produce about 56 kg of carbon monoxide (CO). Therefore, if only one million tones have been burnt each year, the total amount of carbon monoxide (CO) would have reached to 56,000 tones. This indeed, will cause increased the rate of air pollution which is considered the primary reason of infection by cancer disease. (California Agricultural Magazine 1991). There are great efforts towards recycling rice straw to reduce the environmental pollution during rice threshing season and rapidly clear the fields from straw for useful applications as animal feeds and in paper and wood industry. Other utilization techniques may be represented in composting to produce organic fertilizers (Saher 2008)

Alexandrov (1981) mentioned that belt conveyors are suitable for wide-speed application in various fields for moving diverse unit loads and bulk materials. They cope with hauling loads from one location to another within the process in inline production. It is of high handling capacity, simple construction, light weight, operational reliability, convenience, and comparatively low power consumption which are other advantages.

Srivastava, et al. (1993) mentioned that the bale density of the straw is affected by the type of material being baled, its moisture content at time of baling and the resistance provided by convergence of the bale chamber. They also proposed the following equation to determine the baling rate of a rectangular bale as follows:

$$m_f = \frac{d_c w_c d_s p_c n_c}{60}$$

where:

mf = baling rate (kg/s)      dc = depth of bale chamber (m)  
wc = width of bale (m)      ds = thickness of compressed hay (m)  
pc = density of hay of bale (kg/m<sup>3</sup>)      nc = crank speed (rpm)

Baiomy et al (1999) reported that the rice crop property has following parameters: physical properties of rice (Giza 175), the height 110, average diameter 3.5 mm and moisture content (straw 25%, grain 16.1%) and found that the cylindrical type thresher gave the least grain losses, highest capacity, lower cost than the other types and high cleaning efficiency.

Afify, et al. (2002) stated that the baler productivity and the bale density increased by about 25% and 30% as the baler feeding rates increased from 1.5 to 1.8 ton/h. and from 1.8 to 2.2 ton/h, respectively. The total cost of baling decreased with an increase of the baler feeding rates. The highest value of the total cost of baling 682.5 L.E. /h. was obtained at the lowest level of the baler-feeding rate 1.5 ton/h. The total cost of baling decreased by about 30% when the baler-feeding rate increased from 1.8 to 2.2 ton/h. The average value of the total cost of balling using manual picking up increased by about 40% compared with that at the mechanical picking up. These may be due to the increase in the total workers required for collecting the straw and feeding the baler with manually.

Abd El-Mottaleb (2002) found that the pick up baler requires minimum values of fuel, power and energy 7.5 lit/fed., 13.8 kW and 20.3 kW.h/fed of rice straw, while maximum values were noticed with the use of both round baler 14 lit/fed. 27 kW and 38 kW.h /fed of rice straw and stationary baler 28 lit/fed. 19 kW and 76 kW.h/fed of rice straw.

### **MATERIALS AND METHODS**

The objectives of this study are to design a proposed mechanical system attached to the output of cylindrical thresher to convey and feed rice straw directly to the baler to reduce the pollution in the rural farm. The experiments were carried out during seasons (2005 and 2006) at El-Gemmiza Research Station in El-Gharbia Governorate.

First-trial design of the proposed mechanical system. It consists of the cylindrical thresher machine, the belt conveyor with two sheet metal boxes, baler and two tractors as shown in fig. (1). There is a clothing tube was connected between the thrower output of the threshing machine (first box) and the feeding opening of baler (second box).

Second design of the proposed mechanical system: It consists of cylindrical thresher machine, a belt conveyor; clothe tube, a baler and two tractors as shown in fig. (2).

Design of the belt conveyor: The actual belt conveyor length was designed to be 3000 mm, which is suitable for a thresher thrower type. Its width is 750 mm, which was designed to be suitable for baler feeding. The height was variable to be adjusted opposite to the site of the machine thrower outlet and the height of feed opening of the baler. The belt conveyor was designed to be telescopic. This design is to facilitate the changing process of the length according to the operating condition and to easily transported from place to another. The main frame consists of two main units: lower frame and upper frame. Fig. (3) shows a photo of the proposed belt conveyor, Fig. (4) shows a 3-D drawing of the belt conveyor and Fig. (5) shows the main assembly of the belt conveyor.

- Lower frame of the belt conveyor: It was fabricated from steel sheets of thickness 3 mm. It forms a rectangular shape 1500 x 820 mm and formed in the shape of C channel 100 x 50 mm.

Legs: Four legs were fabricated from steel angles (50x50x5 mm)

Wheels: Four wheels were fixed to the lower frame to facilitate its movement in the field.

- Upper frame of the belt conveyor The upper frame of the belt conveyor was fabricated from steel sheets, of 3 mm thickness. The upper frame consists of the belt frame, drums, transmission system, belt, and linen cover

i-Belt frame of the belt conveyor: It was fabricated from steel sheets, of 3 mm thickness, with the shape of C channel (240 mm x 50 mm).

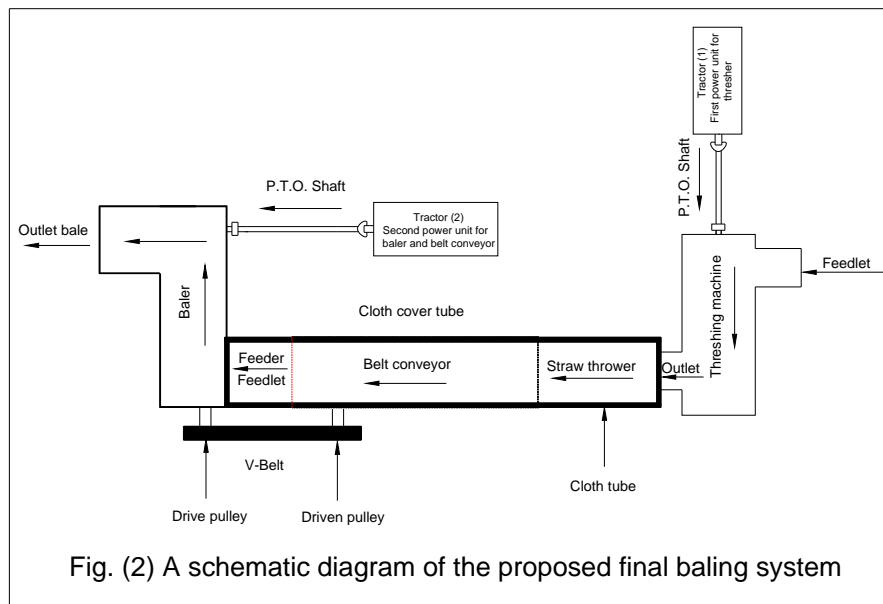
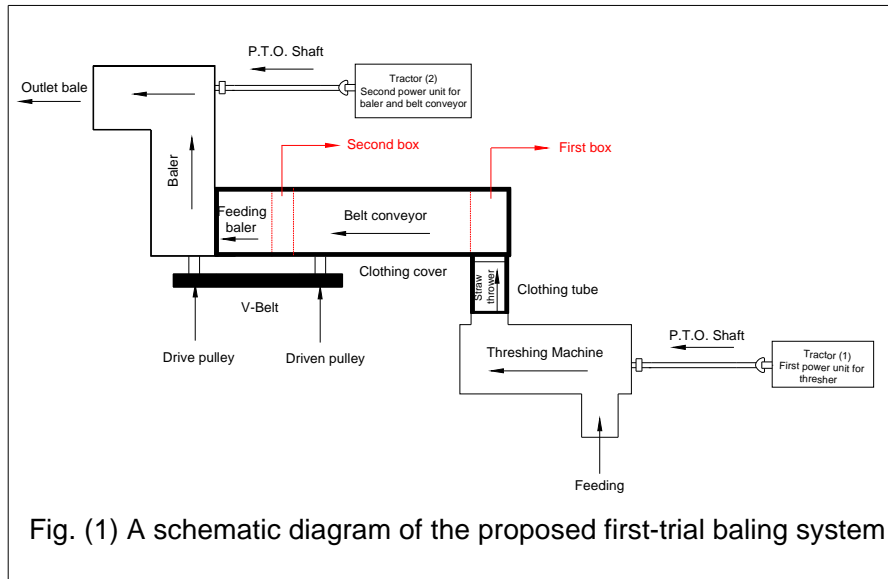
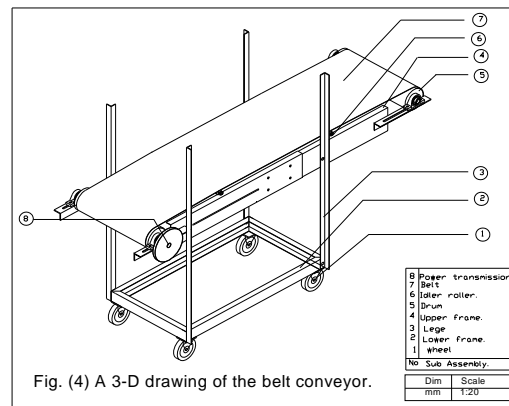

Fig. (3) Photo of the proposed belt conveyor.



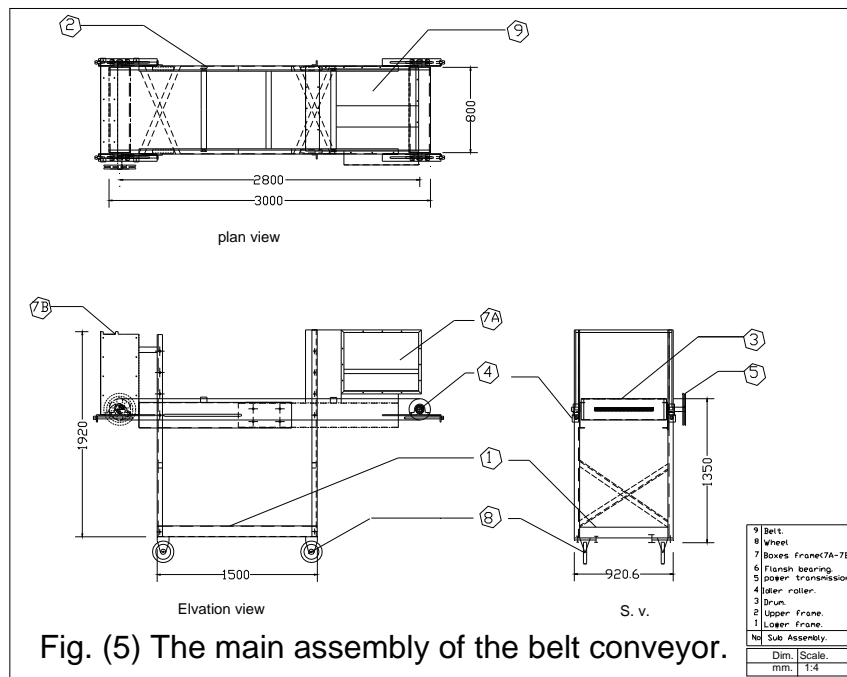

Fig. (5) The main assembly of the belt conveyor.

**ii-Drums:** Two drums were fabricated from steel pipe. Upper frame was provided with three idlers rollers 50 mm diameter to support the upper frame and bear the belt.

**iii-Transmission system:** The required power for the belt conveyor were taken from baler, via a v-belt connecting between the baler pulley, after modification and a pulley was mounted on the belt conveyor.

**iv- Belt:** It was chosen as advantages were; high elasticity, high strength and resistance of the operation conditions. The dimension of the belt were: Length 6000 mm. Width, 750 mm. Thickness 3 mm. Weight 8 kg.

**v- Linen cover:** A linen cover was used over the belt conveyor to prevent pollution during operation. The dimensions of the linen cover were 6000 mm length and 2000 mm width. It was made from linen. Its weight is 4 kg.

**Design calculations and procedures in building up the proposed mechanical systems.:**

Both of the description and design calculations of the proposed systems are introduced. Power calculation and the design calculation of each member used in constructing the conveyor are present. The velocity of the belt in m/s was calculated from equation:  $v = \pi n d / 60$

The velocity of  $v_1, v_2, v_3, v_4$  and  $v_5$  are 0.39, 0.71, 0.79, 1.47, and 1.68 m/s were used at design calculation and experiments. Design calculations were included all the following:

-The power requirements of belt conveyor without and with load were calculated from equations presented by (El-Sahrigi, 1997). And the Total power of belt conveyor =  $P_1$  without load +  $P_2$  with load

-Forces and moments imposed on each leg of the belt conveyor by using the following free body diagram and their calculations at two axes y and x

$F_{total} = \text{resultant force} = (W_{straw} + W_{belt} + W_{steel} + W_{drum} + W_{bearing})$   
Weight of straw on the belt conveyor was calculated from the following equation:

$Q = 3.6 W \cdot V$  (El-Kady and El-Shazaly, 1971) cited by (Mosa, 1998). Steel, belt, rollers and bearing weights are calculated from the following equation:  $m = \rho \cdot v$  -  $F_x$  can be determined from the equation:  $H = F_1 \cdot v$        $F_1 = F_1 + F_2 / 2$        $F_x = F_1 + F_2$

- Bending moment at the leg of the belt conveyor (BM). can be calculating by using the following Equation:  $(BM) = F_x \cdot L$

- Normal stress at the leg of the belt conveyor. It can be calculated from the following equation

- The shear stress at the leg of the belt conveyor can be calculated  $\sigma_N = \frac{F_y}{4} / A$   
 $\tau_s = \frac{F_x}{4} / A$  from the equation (Shigley 1989).

- The bending stress at the leg of the belt conveyor. It was calculated from equation  $\sigma_B = \frac{MY}{I}$  (Shigley 1989).

- The combined stress imposed on the leg of the belt conveyor ( $\tau_L$ ) can be calculated from the equation:  
 $\tau_L = \sqrt{(\sigma_N + \sigma_B)^2 + (\tau_s)^2}$

-The combined stress imposed on the end drum was calculated as:

1- Force resultant on the drum  $F_{res.} = \sqrt{F_x^2 + F_y^2} =$

2- Torque on the drum: It is calculated from the equation:  $T = \frac{P}{\omega}$

3- The shear stress at the drum ends ( $\tau_s$ ) The

transmission shaft diameter based on tensional stress with the selected material chosen to be 40 mm. The shear

stress at the drum ends can be calculated

from the equation: represented by (Hall et al. 1980).  $\tau_s = \frac{16T}{\pi d^3}$

- The bending stress at the drum ends ( $\delta_b$ ) can be calculated using the following free body diagram of drum  $\delta_b = \frac{MC}{I}$ .

-The combined stress imposed on the end drum ( $\tau$ ) can be calculated from the equation.

$M = F_{res} \cdot L/2$        $\tau = \sqrt{\left(\frac{16T}{\pi d^3}\right)^2 + \left[\frac{F_{res}}{A} + \frac{Mc}{I}\right]^2}$

- Checking the welding joint checked against the stresses from were through the equation:  $\tau = \sqrt{\left(\frac{F_y}{A}\right)^2 + \left[\frac{F_x}{A} + \frac{My}{I}\right]^2}$

- Length of the belt can be determined from equation:

$$L = \pi (r_1 + r_2) + 2x + (r_2 - r_1)^2 / 4x \quad (\text{Paul 1983}).$$

**Equipments:**

**Threshing machine:** The cylindrical threshing machine was selected. Threshers' specifications is:

Type : Axial flow system;      Manufacture : Local.

Power source: 35 – 65 Hp tractor PTO shaft belt pulleys.

Feeding : all crop (panicle and straw)

Overall dimensions: Length:285 cm., Width:135., Height:200 cm.

**Baler:** John Deere baler was chose to facilitate obtaining the power from it, to operate the belt conveyor. Baler specifications is:

Cross section : 35.6 x 45.7 cm      Bale length : 30 to 127 cm

Source of power : P.T.O. 540 rpm.

Plunger stroke : 80 (strokes per min)

**Tractors:** Two John Deere tractors 65 hp are used in the experiments. The first tractor is used to operate the cylindrical threshing machine. The second tractor is used to operate the baler and the belt conveyor.

Tractor specifications is: Model tractor: 4055 DSI, type of engine water cooled diesel turbo charger and 6 cylinders



### **Experiments of the proposed mechanical systems:**

The performance of the proposed mechanical system during the baling process was measured. Such measurements included determination of the optimum speed of the belt conveyor, the consumed time of the bale. The impact of the proposed mechanical systems on the environment was also studied. Comparisons between the pollution produced from the mechanical systems with the pollution produced from the traditional system were performed.

**i- First-trial of the proposed system:** It was operated. But this system caused a higher pollution than the final proposed mechanical system.

**ii- Final proposed mechanical system:** The cover extends to be fixing on the outer frame of the feeding opening of the baler, in order to prevent the spreading of dust. The final mechanical system achieved minimum pollution to environment.

**4-Measurements:** The currently factors surrounding the environment of experiments, and the measurements were recorded during the operation. As shown in table (1)

**Table (1) The measurements of factors recorded during the experiment.**

<b>Factors</b>	<b>Measurements</b>
Type of rice	Sakha 101
Grain/straw ratio	1.1 : 1
Machine capacity (ton/h)	2.9 ton/h
Air speed (m/s),	2.2 m/s
Temperature atmospheric ( <sup>0</sup> c)	20 <sup>0</sup> c
Humidity atmospheric (%)	29.8 %

**i- Physical properties of rice straw:** Thirty stalks of rice straw plan were chosen after thresher as a random sample; some measures were processed on them as length, diameter and weight. The average values were calculated.

**ii- Mechanical properties of rice straw:** Coefficient of friction and load-extension property of rice straw (stiffness) were measured at two different moisture content samples. A Hay moisture tester measured moisture content and temperature. Model (HTM-1) and range of (1% to 40 %).

**Coefficient of friction of rice straw:** A local device was used to measure the suitable angle to operate the belt conveyer. It was measured with three different surfaces (metal sheet, wooden sheet and linen belt sheet). It was estimated from the following equation:  $\mu = \tan \theta$

Where:  $\mu$  = coefficient of friction.  $\theta$  = the friction angle.

**Load-Extension property of rice straw (stiffness):** Force-deformation test model (universal tester-Lloyd x Instrument type LR 5 KN load cell) was used for the force-deformation test, extension tests and compression-extension tests. Load-extension property of rice straw (stiffness) was determined at two different moisture contents samples 18% and 25%. The stiffness (K) of the rice straw was calculated from equation:-

$$K = \frac{F}{L} \quad N/mm$$

where:

K = stiffness, N/mm. F = load, N. L = extension, mm.

**Density of bale:** The obtained bales were weighed. The density was calculated by dividing the bale weight by the bale volume (500 mm x 400 mm x 1000 mm),

**iii-speeds of straw:** A Hygro-thermo-anemometer was used to measure air velocity, temperature and relative humidity. Model: (407412). Air velocity range is (0.4 – 25.00 m/s) accuracy ( $\pm 2\% + 0.2$  m/s), and temperature range (0 °c to 50 °c). Relative humidity range is (10 to 80 % RH). Speeds were measured, at variable distances from thresher, into the cloth tube, 0, 1, 2, and 3 m. It is important to push the straw from the thresher machine.

**iv- The belt conveyer speed:** A photo/contact tachometer was used to measure the rotary speed of the threshing machine, baler and belt conveyer. It ranged from 0.5 to 19,999 rpm., accuracy  $\pm 0.05\%$ . The experiments were applied at different drum speed of the belt conveyer, the speed were 0.39, 0.71, 0.79, 1.47, and 1.68 m/s, to get suitable drum speed for transport the straw from threshing machine to baler.

**v- The power required for baling:** The required power was calculated by using the following equation (Hanna, 1985)

$$HP = F_c \cdot \sigma_f \cdot C_v \cdot (4270 / 750) \cdot 0.735 \quad KW$$

where:

HP =The required power, kW

$F_c$  =The fuel consumption, L/s(depends on the engine condition)

$\sigma_f$  =Density of the fuel, kg/L (for solar fuel = 0.85 kg/L)

C.v = Calorific value of fuel, k. cal /Kg (average C.v (calorific value of solar fuel is 10000 k. cal /Kg);

4270 = Constant (thermo-mechanical equivalent of heat, kg. m/Kcal.

### **vi- Energy requirement for baling**

Energy requirement was calculated using the following equation:

$$\text{Energy requirement (kW.h./fed)} = \frac{\text{Baling power (kW)}}{\text{Actual field capacity (fed./h)}}$$

### **vii- Baling costs**

To estimate the system cost, the belt conveyor cost and the baling cost were determined as follow: Baling costs was determined using the following equation: (Awady, 1982):

$$C = \frac{P}{h} \left( \frac{I}{a} + \frac{I}{2} + t + r \right) + (1.2 w.f.s.) + \frac{m}{144}$$

where:

C = Hourly LE/h P =Price of the machine, LE

H= Yearly working hours

A= Life expectancy of the machine, years. I = Interest rate/year

t =Taxes over heads ratio, r =Repairs and maintenance ratio

w=Power, hp f =Specification fuel consumption, Lit/hp

s=Fuel price, LE/lit m =Operator monthly salary.

1.2 =Factor accounting for lubrications

144 =The monthly average working hours

### **-Measuring the dust during the operation**

The personal dust sampler was used to measure dust during operations. The suction flow rate of the dust sampler was adjusted to be at 1.5 L/min, before the beginning of work the filter was weighed and weighed at the end of working day, to determine the difference between the two weights. The following equations were used. Flow rate = 1.5 L / min = 0.09 m<sup>3</sup>/h.

Respiratory air volume during workday (m<sup>3</sup>/day):

$$(\text{m}^3/\text{day}) = 0.09 \times \text{work hours per day} .$$

Dust weight (mg/h) = measured dust weight, mg/work Hours.

Dust weight per air volume (mg/m<sup>3</sup>) = dust weight mg/h/air Volume (m<sup>3</sup>/h).

## RESULTS AND DISCUSSION

### 1- Features of the belt conveyor

The height of the outlet of the thresher from the ground was 1250 mm; the height of the input of the baler from the ground was 1000 mm. The experiments have been carried out at five the speed of the conveyer belt (0.39, 0.71, 0.79, 1.47, and 1.68 m/s).

The design calculations proved that the design of the belt conveyor is very safe. The dimensions of the belt were 2.8 m effective length, 0.75 m width. The force imposed on the belt conveyor was 1067 N. shear stress ( $\tau_s$ ) was 0.014 M Pa, Bending stress ( $\sigma_b$ ) was 1.09

MPa, the combination force imposed on the leg of the belt conveyor ( $\tau_L$ ) was 1.13 M Pa. The require power to operator the belt conveyor was 1.98 kW.

### 2- Physical and mechanical properties of rice straw:

Physical properties of stalks straw were measured and recorded as shown in table( 2 )

**Table (2) Physical properties of stalks rice straw**

Characteristics	Average of rice straw before threshing	Average of rice straw after threshing
Diameter	2 mm	2 mm
Length	650.6 mm	350 to 460 mm
Moisture content	20%	18%

**Coefficient of friction of rice straw on three surfaces was 0.9** with (Metal sheet),1.07 with Wood sheet and 1 with Linen sheet

**Load-Extension property of rice straw (stiffness)** Load-extension tests of straw were measured and recorded as shown in table (3). As the humidity increases, the elasticity increases. While the stiffness decreased. Thus, means the optimum threshing process will be carried on at dry rice straw very low humidity percentage.

**Table (3): Effect of moisture content on stiffness of rice straw.**

Moisture content %	Max. Load N	Extension mm	Stiffness (K) N/mm
18 %	118.2 N	2.686 mm	44
25 %	92.16 N	3.456 mm	27

## **Performances analysis of the mechanical systems**

**1- Effect of distance in front of the throw opening on the straw throw speed through a tube:** The straw thrower speed decreases as the distances increase. When distances in throwing opening from threshing machine were 0.0, 1.0, 2.0 and 3.0 m the straw thrower speeds were slightly decreased and dropped in at about 3000 mm, through the cloth tube. For this reason the length of the conveyor belt is 3000 mm. .

**2- Determination of the optimum speed of the belt conveyor:** Two factors affect the determination of the belt conveyor speed: To minimize, the consumed time of the bale and to avoid accumulation of rice straw at the inlet of the baler.

Table (4) shows the relationship between the belt conveyor speed (m/s) and the consumed time of the bale (s). Fig. (6) shows the relationship between the belt conveyor speed (m/s) and the consumed time of the bale (s).

**Table (4):The relationship between the speed (m/s) of the belt conveyor and the consumed time of the bale (s).**

<b>Belt conveyor speed (m/s)</b>	<b>Consumed times of the bale (s)</b>	<b>Accumulation of rice straw</b>
0.39	930	No stacking
0.71	375.6	No stacking
0.79	152.4	No stacking
1.47	78	No stacking (optimum)
1.68	37.2	Stacking appear

## **3- Effect of inclination angle of the belt conveyor on the baling process**

Changing the inclination angle of the belt conveyor leads to accumulating the straw inside the clothing tube. Thus, the horizontal position of the belt conveyor is must to avoid such difficulties.

## **4- Impact of the function of the proposed mechanical systems on the environment.**

The pollution was measured due to operating the proposed mechanical systems, to surrounding environment and operators. In addition, a comparison between the pollution produced from

the mechanical system with the pollution produced from the tradition system

The total dust collected during operating the first proposed system was about 12.6 g/m<sup>2</sup>.h, while the total dust collected during operating the final proposed system was 7 g/m<sup>2</sup>.h.

Table (5) shows the relationship between the of the belt conveyor speed (m/s) and the quantities of dust (mg/m<sup>3</sup>) inhaled during operating the mechanical systems. Fig. (7) shows the relationship between the belt conveyor speed (m/s) and quantity of dust

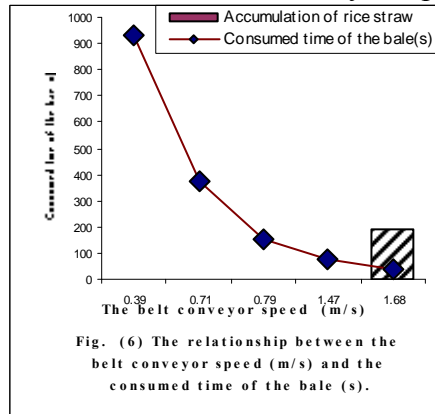

Fig. (6) The relationship between the belt conveyor speed (m/s) and the consumed time of the bale (s).

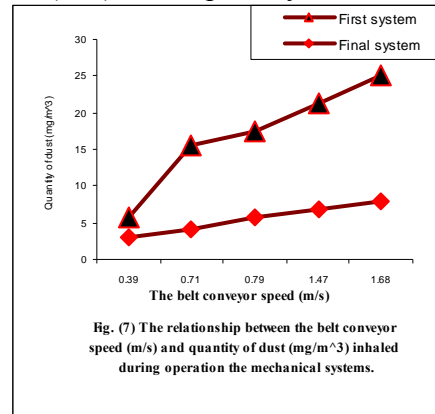

Fig. (7) The relationship between the belt conveyor speed (m/s) and quantity of dust (mg/m<sup>3</sup>) inhaled during operation the mechanical systems.

(mg/m<sup>3</sup>) inhaled during the operating the mechanical systems.

**Table (5) The relationship between the belt conveyor speed (m/s) and the quantity of dust (mg/m<sup>3</sup>) inhaled during operating the mechanical systems.**

The belt conveyor speed (m/s)	Quantity of dust (mg/m <sup>3</sup> )	
	First system	Final system
0.39	4.5	3
0.71	15.5	4.2
0.79	17.5	5.6
1.47	21.4	6.7
1.68	25	8

Figure 6 and table 5 shows that the increase of belt speed with increase the dust in the area around the system. The rate of increasing dust speed was higher in case of the angle feeding of the mechanical system. Also, the value of dust around the system was much higher in case of angles feed. Dust speed in the area of labor inhalation was graduated 4.5 to 25 mg/m<sup>3</sup> as the belt speed increased from 0.39 m/s to 1.68 m/s. In contrast the value of dust

speed in the area by the direct feeding mechanical system increased with the range 3 to 5 mg/m<sup>3</sup> at the same range of speed. The increase of dust pollution due to higher speed is understood because the belt motion move the ambient air and cause more disturbance of the dust. Also at higher speed more forces generated when straw falling on the top of the belt that may stir dust. The difference of dust pollution due to the feeding system is also clear. In case of angle feeding the straw has to change the direction of motion suddenly. The straw hit the wall of the canvas and fall down to the top of the belt. More dust throw height from the straw due to the impact against the canvas tube. The straw change direction of motion when it hit to the end of the canvas to be conveyed in a perpendicular direction by the belt. On the other hand, the direct feed enables the straw to move in the some direction of the belt motion. The straw still suspended in the air inside the canvas tube until it settle down on the top of the belt. The dusts also settle down where no change in the direction motion and no impact to an objecting canvas.

Table (6) shows a comparison between the pollution rate for the traditional system and the proposed systems running. Also between the quantity of dust inhaled by operators during running traditional system and the proposed mechanical systems at the optimum speed.

**Table (6): A comparison of the pollution rate for the traditional system and the proposed mechanical systems**

Comparison	Suspended, g/m <sup>2</sup> .h	Deposited, g/m <sup>2</sup> .h	Total, g/m <sup>2</sup> .h	Quantity of dust ( mg/m <sup>3</sup> )
Traditional system	588.08	929.55	1517.63	32
First system	9.4	3.2	12.6	21.4
Final proposed system	5.6	2.4	8	6.7

**6- Power requirement**

From equation the power requirement was calculated for operating the belt conveyor (HPB) and for operating the baler and the belt conveyor (HPT) at different speed by measuring fuel

consumption at same speed as shown in table (7) the power requirement increases as the speed belt conveyor increases.

**Table (7) The relationship between fuel consumption, power requirement, energy and the belt conveyor speed\*.**

belt conveyor speed (m/s)	FCT (Lit/h)	FCB (Lit/h)	HPT (kW)	HPB (kW)	Energy KW. h/ton	Energy KW. h/bale
0.39	1.98	0.06	19.56	0.593	117	5
0.71	2.016	0.096	19.92	0.95	48.3	2
0.79	2.1	0.18	20.75	1.78	20.5	0.88
1.47	2.21	0.2	21.84	1.98	11	0.48
1.68	2.3	0.38	22.73	3.76	5.5	0.24

**8- Cost estimation:** From equation the total cost of baling is 85 LE/h. Tractor cost is 15.8 LE/h. Cost fabricated and the components the belt conveyor was 2000 LE.

Using the mechanical system leads to reduce the cost of baling, because it saves the transport, collection, and feeding the baler labors, by comparing the traditional processes.

The mechanical system needed one labor to feed the thresher. Baling costs less than the comparison of the traditional processes. As a result no labors in this system

Increasing the baler feed rate to 2 ton/h by using the proposed mechanical system.

Using the proposed mechanical system leads to reduce the pollution during threshing process on the surrounding environment.

### **Conclusions And Recommendations**

1- The best distance between the thresher and the belt conveyor was 2 m that is due to the thrower straw drop at the 3 m far from the thrower opening.

2- Best optimum speed of the belt conveyer was 1.47 m/s, the best baler feed rate "2 t/h" the optimum consumed time 78 s/ bale.

3- Best inclination angle of the belt conveyer was horizontal (0).

4- The proposed mechanical system reduced the pollution to 80%.

5- The mechanical system leads to reducing the cost of baling.

The recommendation to use the mechanical system is for the following reasons:



- 1- Reduction of pollution arising from the thresher machines
- 2- Saving the labors from one by the mechanical system to 15 by the traditional system.
- 3- Avoiding getting rid of the rice straw by the recent methods as burning or accumulation on the road sides.
- 4- Rapid cleaning of rice straw from the field during the threshing process.
- 5- Rapid preparation of the field for the next crop, which increase the usefulness of the area.

#### REFERENCES

- **Abd El-Mottaleb, A. F. 2002.** Comparative study between pick up, stationary and round balers. *Misr J. Ag. Eng.*, 19 (1) pp. 23-39
- **Afify, M. T.; A. H. Bahnasawy and S. A. Ali, 2002.** Effect of rice straw picking up method on the performance of a rectangular baler. Written for presentation at the AIC 2002 Meeting CASE /SCGR program Saskatoon, Saskatchewan July 14-17. pp. 1-15
- **Agricultural Magazine, 1999.** The scientific face to the black cloud towards best investment of the agricultural residues. Dec., Year 41 (493) pp. 17-20.
- **Awady, M. N.; 1982.** Engineering of tractors and agricultural machinery. Arabic Text. 5<sup>th</sup> Ed. Pp 161- 164.
- **Baiomy, M. A. and Y. F. Sharobeemm, 1999.** Comparative evaluation of rice harvesting and threshing of small farms. The Center for Research and Technological Development Studies. The first conference. and the challenges of the next century. Helwan university. Egypt.
- **California Agriculture Magazine 1991.** 199 Volume 47 part 4 (July, August),
- **El-Gindy, A. M.; M. A. Gad alaa; M. A. Baiomy and Sahar, El- S. Mosa, 2001.** A study on the effect of threshing mechanization systems on environmental pollution. *Journal of environmental science*, 3 (2) pp. 415-435.
- El-Gindy Abd-El-G. M., Mohsen Abd-Gad-Allah, Magdy A. Baiomy and Sahar E. A. Mousa 2005,** Environmental Pollution Caused by Cereal Crops Threshing Mechanization Systems Affecting Human Health. International Conference of Agric. Mechanization, Yasmine Hamm mat – Tunise 9 – 11 November, P: 323-333.

- **El Sahrigy, A. F. and Z. A. El-Haddad, 1982.** The national plan of form mechanization in Egypt from (82/83 to 86/87) prepared by Technical Office of Agric. Mechanization project attachment (3b) pp7.
- **Hanna, G. B.; A. M. Berry; and M. M. Danasory, 1985.** Intensifying the use of mowers under Egyptian conditions, J. of Cairo Univ.
- **Mosa, Magda M. 1998.** Engineering factors affecting the development of grading machine for citrus. Ph. D. Thesis faculty of agriculture, Cairo University.
- **Paul H.B. and O.E. Adams, 1983.** Machine design. Mc Graw-Hill International Book Company. Third edition. pp. 287.
- **Saher El. A. M. 2008.** Design of Mechanical System Hooked with Threshing Machines to Convert Rice Straw into Bales to Reduce Pollution of Environment, Unpublished Doctor of Philosophy, Ain Shams University, Institute of Environmental Studies and Research
- **Shigley, J. E. and C.R. Mischke, 1989.** Mechanical engineering design. Mo Graw- Hill Publishing Company. New York.

### المراجع العربية

- السهرجي، أ. ف. 1997 أساسيات هندسة التصنيع الزراعي- المكتبة الأكاديمية- القاهرة

### الملخص العربي

" تصميم, وتصنيع منظومة ميكانيكية لتداول قش الأرز في بالات للحد من التلوث البيئي "

يعتبر المنتج الثانوي (قش الأرز) ذي قيمة غذائية عالية والذي يمكن استخدامه مباشرة كغذاء للحيوان دون إضافات بهدف تعظيم الاستفادة من المحصول ككل. وعلى الرغم من الأهمية الاقتصادية لمحصول الأرز، إلا أنه يتسبب في مشكلة بيئية بالغة الخطورة نتيجة لحرق قش الأرز بعد الحصاد. ولذلك كان الهدف الأساسي من البحث هو تصميم منظومة ميكانيكية ملحقة بآلات الدراس والتذرية، لنقل قش الأرز أثناء الدراس مباشرة إلى المكبس، فتعمل كل من ماكينة الدراس والسير الناقل المصمم (المنظومة الميكانيكية) والمكبس كوحدة واحدة في نفس الوقت، مع المحافظة على البيئة المحيطة والعامل من التلوث إلى أقل قدر ممكن. تم تصميم سير ناقل للربط بين ماكينة الدراس والمكبس، وكانت أبعاد السير (3 متر) طول و(0.75 متر) عرض، أما الإرتفاع فكان متغيرا ليناسب إرتفاع فتحات الطرد والتغذية في ماكينات الدراس والمكابس. وتم تغطية

النظام بالقماش لعدم تسرب الأتربة. تم تحليل قوة السير. وتقدير كل الإجهادات على كافة القطاعات المختلفة ثم فحصها وتقديرها. تم إختيار كراسى رومان بلى طبقا لقدرة حمل النقل. وتم فحص لحام الوصلات ضد الإجهادات. وتم الإمداد بكل حسابات القوى للدلالة على قدرة الجرار.

لتقييم أداء النظام المقترح أجريت كثير من التجارب والإختبارات، تم تشغيل السير على سرعات مختلفة للوصول إلى أنسب سرعة للموامة بين كمية القش الناتجة من الماكينة وكمية القش المغذية للمكبس للحصول على باله فى زمن مناسب لعدم إهدار الطاقة للماكينة والمكبس. وكانت سرعات التجربة للسير هي (0.39 ، 0.71 ، 0.79 ، 1.47 ، و 1.68 متر/ثانية) والزمن المستهلك لخروج الباله عند هذه السرعات هو (930، 375.6، 152.4، 78 و 37.2 ثانية) على التوالي .

- تم تشغيل المكبس على سرعة ثابتة 160 لفة/ دقيقة ، وكانت سرعة درفيل الدراس للماكينة 600 لفة/ دقيقة (سرعة ثابتة) .

- كانت أبعاد الباله الناتجة من المكبس هي: 100 سم ، 50 سم ، 40 سم طول ، عرض وإرتفاع على التوالي . وكان متوسط وزن الباله 43كجم .

- تم قياس كمية الأتربة المستنشقة عند مصدر تسرب الهواء الأوحد فى النظام عند السرعات المختلفة فكانت (4.5 ، 15.50 ، 17.50 ، 21.40 ، 25 مجم/م<sup>3</sup> ) بالنسبة للنظام المقترح بينما كانت كميات الأتربة بالنسبة للنظام المعدل هي ( 3 ، 4.2 ، 5.6 ، 6.7 ، 8 مجم/م<sup>3</sup>) وذلك عند سرعات للسير المغذى مقدارها 0.39 ، 0.71 ، 0.79 ، 1.47 و 1.68 متر/ ثانية على التوالي . علما بأن أقصى معدل تلوث بالأتربة مسوح به بالهواء طبقا للوائح منظمة الصحة العالمية هو 9.20 مجم/م<sup>3</sup> . وفى دراسة سابقة (EI- Gindy, et al., 2001) سجلت ماكينة الدراس البرميلية أعلى تلوث للبيئة المحيطة والمستنشقه بواسطة العامل ومقارنتها بالنتائج الحالية.

- تقليل العمالة حيث يحتاج النظام المقترح إلى عامل واحد لتغذية الماكينة فى حين تحتاج النظم التقليدية إلى 15 عامل للتجميع الكمية المطلوبة حيث يقوم هؤلاء العمال بعملية نقل قش الأرز وتغذية المكبس. وبالتالي خفض تكاليف عملية كبس القش مما يسهل عملية نقله وتداوله ويشجع المزارع على الإهتمام به كمنتج ثانوى ذو مردود إقتصادى.