

## PERFORMANCE EVALUATION OF FLOPPY SPRINKLERS

El-Sayed<sup>\*</sup>, A. S.; Hegazi<sup>\*\*</sup>, M. M.; El-Sheikh<sup>\*</sup>, I. H. and Khader<sup>\*</sup>, A. F.

### ABSTRACT

*The aim of this research was to evaluate the performance of two types of floppy sprinklers, original type and local type to determine optimum operating conditions that achieve high application efficiency. The coefficient of uniformity (CU), distribution uniformity (DU) and application efficiency of low quarter (AELQ) were evaluated under different levels of operating pressure and riser height. It was concluded that the operating conditions that achieved high coefficient of uniformity, distribution uniformity and application efficiency of low quarter were operating pressure of 200 kPa and riser height of 2.0 m for both types of floppy sprinklers. The corresponding values of CU, DU and AELQ were 70.65, 52.59 and 44.33 % for original and 66.67, 44.31 and 37.46 % for local, respectively. Also, to achieve high percentage of overlap simulation model was used, it appeared that the spacing between sprinklers should be higher than or equal 50 % of wetted diameter to avoid water lose and minimize irrigation system cost.*

### INTRODUCTION

Sprinkler, trickle and subsurface irrigation methods are relatively modern techniques which have many advantages. Sprinkler irrigation is a relatively new method in Egypt especially in the newly reclaimed areas due to its high control of water distribution and suitability to most of soil and crop types. Also, sprinkler irrigation distributes water more uniformly than any other methods (**El-Ansary et al., 2003**). **Keller and Bliesner (1990)** stated that there are several factors affect the water application efficiency of sprinkler irrigation system such as variation of individual sprinkler discharge throughout the lateral lines, variation in water distribution within the sprinkler spacing area, loss of water by direct evaporation from the spray and evaporation from the soil

---

<sup>\*</sup>Prof., Assistant Prof., and Demonstrator of Agric. Eng., Agric. Eng. Dept., Fac. of

Agric., Suez Canal Univ.

\*\*Prof. of Agric. Eng., Agric. Eng. Dept., Fac. of Agric., Ain Shams Univ.

surface before the water is used by the plants. Also, the sprinkler performance is affected by operating pressure and riser height. **Ismail (1985)** showed that when the operating pressure increased from 220 to 275 kPa, the application efficiency of low quarter (*AELQ*) values ranged between from 75.70 % to 52.70 % under low-pressure center pivot sprinkler irrigation system.

**Tarjuelo et al. (1999)** investigated two types of sprinkler soiled-set and center pivot system. They showed that when the operating pressure increased from 210 to 480 kPa, the average value of (*CU*) was 84.59 % for soiled-set system and when the operating pressure increased from 55 - 375 kPa, the (*CU*) values decreased from 87.16 % to 84.25 % for center pivot system. **El-Sherbeni (1994)** found that when riser height increased from 50 to 150 cm, the coefficient of uniformity (*CU*) values decreased from 78.50 % to 72.0 % for Rain Bird sprinkler and from 84.60 % to 65.0 % for developed sprinkler under the same operating pressure of 150 kPa and nozzle size of 3.5 x 2.4 mm. **Abo-Ghobar (2003)** investigated the spray losses from three low-pressure center pivot sprinkler irrigation systems under field operating conditions. The evaporation losses during sprinkling were determined at three different spray-nozzle heights from ground surface. The average values were 15.63, 21.19 and 35.77 % for heights of 1.25, 1.75 and 2.5 m, respectively. **Ismail (1985)** showed that when the operating pressure increased from 220 to 275 kPa, the application efficiency of low quarter (*AELQ*) values ranged between from 52.70 % to 75.70 % under low pressure center-pivot sprinkler irrigation system.

**Griffiths and Lecler (2001)** evaluated of seven floppy sprinklers and 27 sub-surface drip (SSD) systems in terms of field distribution. They found that the coefficients of uniformities of floppy sprinkler were ranged from 66.0 % to 84.0 % and ranged from 53.0 % to 98.0 % for (SSD) system. Meanwhile, the distribution uniformities of floppy sprinkler were ranged from 59.0 % to 78.0 % and ranged from 33.0 % to 94.0 % for (SSD) system. **ITRC (1991) and Schwankl et al. (2003)** suggested (*DU*) values

as excellent (75.0 - 85.0 %), good (65.0 - 75.0 %) and poor (50.0 - 65.0 %). The upper, lower limits and middle values are for multi-stream, single-stream rotor and fixed-spray sprinkler respectively. **Aboamera and Sourell (2003)** attempted to achieve good water distribution for a new sprinkler nozzle called floppy sprinkler at an acceptable irrigation intensity. They found that the averaged Christiansen coefficient of uniformity (*CU*) and distribution uniformity (*DU*) was 88.01 % and 80.94 %, respectively for the 8.0 m of sprinkler and lateral spacing at 1.5 m sprinkler height and 200 kPa operating pressure. **Badr (1992)** found that the distribution uniformity (*DU*) values under fixed sprinkler irrigation system were increased from 69.0 % to 94.6 % for square pattern, from 53.0 % to 83.90 % for rectangular pattern and from 57.0 % to 96.70 % for triangular pattern at operating pressure of 250 kPa.

**Ascough and Kiker (2002)** studied that the application uniformity of different irrigation systems in the sugar industry in five sugar-growing regions in South Africa. The average low-quarter distribution uniformity (*DU*) of center pivot, dragline, micro-irrigation, floppy and semi-permanent sprinkler systems was 81.40 %, 60.90 %, 72.70 %, 67.40 % and 56.90 %, respectively. **Dukes and Perry (2006)** studied the uniformity along the length of a center pivot and a linear move irrigation system. They found that the averaged values of the low quarter distribution uniformity 90.0 % and 74.0 %, respectively for the center pivot and the linear move irrigation system. **Ismail (1995)** found that the best operating conditions were achieved under light wind speed, with 4.0 m distance between the two sprinklers, overlapping 50 % and operating pressure of 200 kPa. **Amer (2006)** found that high degree of water distribution uniformity optimal spacing between spinner sprinklers was found to be as 60 % from diameter of throw in square layout and in range from 50 to 70 % from diameter of throw in triangular. For impact sprinklers, spacing was recommended to be as 50 % from diameter of throw in square layout and in range from 50 to 60 % in triangular. Triangular layout achieved higher uniformity than square even for the same served area.

To design an efficient sprinkler system, it is necessary to determine the optimum operating conditions that achieve high *CU*, *DU*, *AELQ* and excellent distribution efficiency, therefore the main objective of this study was to (1) compare irrigation performance of local floppy sprinkler with original floppy sprinkler and (2) simulate the experimental data to determine sprinkler spacing that achieves optimum water distribution.

### MATERIALS AND METHODS

The experimental work was carried out at the research Farm, Faculty of Agriculture, Suez Canal University. The experimental setup is schematically shown in Figure 1. It consists of a 0.75 kW electric-centrifugal pump connected with a water tank which gives a steady flow of water. Two valves were fitted after the pump to control the flow rate reaching the sprinkler device. A manual pressure regulator (Model 100-PRV) was installed in series to regulate the supply pressure to the test unit of sprinkler system. Pressure gauge (up to 600 kPa) and flow meter were used to approximate the desired pressure at the sprinkler nozzle. An aluminum pipe has diameter of one inch was used to transmit water from pumping set to sprinkler device.

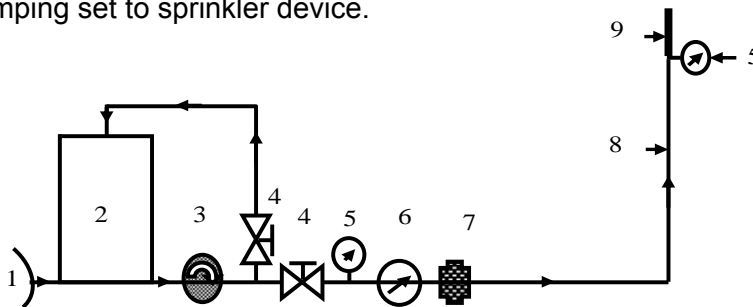

- |                   |                     |                         |
|-------------------|---------------------|-------------------------|
| 1 - Water source. | 4 - Control valve.  | 7 - Pressure regulator. |
| 2 - Water tank.   | 5 - Pressure gauge. | 8 - Riser.              |
| 3 - Pump.         | 6 - Flow meter.     | 9 - Floppy sprinkler.   |

Figure 1: Schematic diagram of the experimental unit.

Two devices of floppy sprinkler, one original type ( $F_1$ ) and other local type ( $F_2$ ) were installed as a permanent system. The unique floppy sprinkler design is suitable for different installation options as required for the crops. The floppy sprinkler consists of a plastic pipe with a flexible silicon

tube mounted inside sprinkler body. When water passes through the tube, it snakes during slowly rotating 360° forming uniform droplets.

Plastic catch cans 120 mm diameter, 80 mm height were located under sprinkler in an across the full circle of sprinkler within the range of the spray nozzles throw to collect the water. The catch cans were distributed according to **(ASAE Standard, 2001)** as it is presented in Figure 2. Spacing of collectors (catching cans) for radius of throw determination is given in Table 1. The floppy sprinkler was evaluated at different levels of operating pressure (100, 150, 200, 250 and 300 kPa) and riser height (1.0, 1.5, 2.0 and 2.5 m) under Egyptian conditions.

Table 1: Spacing of collectors according to ASAE Standard, 2001.

Sprinkler Radius of Throw, m(ft)	Maximum Collector Spacing Center to Center, m(ft)
0.3 - 3 (1 - 10)	0.30 (1.0)
3 - 6 (10 - 20)	0.60 (2.0)
6 - 12 (20 - 39)	0.75 (2.5)
> 12 (> 39)	1.50 (5.0)

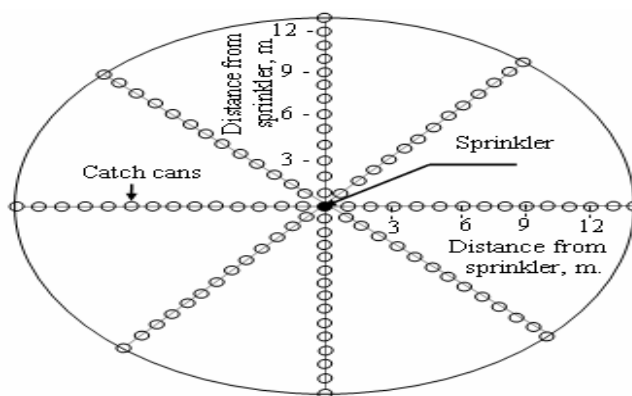

Figure 2: Schematic diagram representing distribution of catch cans. Operating pressure was measured using a pressure gauge with attached pressure pitot tube. The measurement was conducted by centering the pressure needle in the jet 3 mm from the sprinkler nozzle and recording the highest observed pressure.

Flow rate of sprinkler was measured by connecting a flexible tube to the sprinkler nozzle and collecting known volume of water in a container over a specified period (5 min), The flow rate was calculated using the following formula (**Melvyn, 1983**):-

$$Q = \frac{V}{t} \quad (1)$$

Where,  $Q$  is the flow rate of sprinkler in  $\text{m}^3 \text{h}^{-1}$ ,  $V$  is the collecting water volume in  $\text{m}^3$  and  $t$  is time of collecting water in h.

Water application of individual sprinkler was collected by catch cans installed across the full circle of sprinkler under different treatments. The application rate of sprinkler was calculated by the following formula (**James, 1988**):-

$$A = k \frac{Q}{a} \quad (2)$$

Where,  $A$  is the application rate in  $\text{mm h}^{-1}$ ,  $Q$  is the flow rate of sprinkler in  $\text{l min}^{-1}$ ,  $a$  is the wetted area of sprinkler in  $\text{m}^2$  and  $k$ : unit constant ( $k=60.0$  for  $A$  in  $\text{mm h}^{-1}$ ,  $Q$  in  $\text{l min}^{-1}$  and  $a$  in  $\text{m}^2$ ).

The distribution uniformity  $DU$  was calculated by the following formula (**Heermann et al., 1990**):-

$$DU = 100 \frac{Z_{lq}}{Z_{av}} \quad (3)$$

Where,  $DU$  is the distribution uniformity in %,  $Z_{lq}$  is the average catch can depth in the low quarter of the field in mm and  $Z_{av}$  is the average catch can depth in the entire field in mm.

Uniformity tests were conducted by placing several identical collectors in an equally spaced grid in the field around sprinkler. The amount of water caught in each can was measured and recorded and the coefficient of uniformity was calculated by the following equation, **Christiansen (1942)**:-

$$CU = 100 \left( 1 - \frac{\sum |X_i - \bar{X}|}{n \bar{X}} \right) \quad (4)$$

Where,  $CU$  is the Christiansen's coefficient of uniformity in %,  $X_i$  is the individual collector amount in mm,  $\bar{X}$  : mean of collectors amount in mm,

$\Sigma$  is the summation of  $n$  values,  $| |$  is the absolute value and  $n$  is the number of measuring collectors.

Application efficiency of low quarter ( $AELQ$ , %) was calculated by the following formula (**Merriam and Keller, 1978**):-

$$AELQ = 100 \frac{\sum Z_{r,lq}}{D} \quad (5)$$

Where,  $Z_{r,lq}$  is the average low quarter depth of collected water in mm and  $D$  is the average depth of water applied in mm.

The computer software Catch-3D Utah State University Catch-3D (**Allen, 1992**) was used to estimate water application uniformity from catch-can testes. Contour maps were constructed to present water depths, water distribution for all treatments using SURFER program (**Golden Software, 2000**). The computer software was used to draw 3-dimensional curves for the water application patterns to determine the sprinkler spacing that achieves optimum performance.

### RESULTS AND DISCUSSION

The effect of operating pressure on flow rate for two types of floppy sprinklers, original type ( $F_1$ ) and local type ( $F_2$ ), is presented in Figure 3. It is apparent that the flow rate from individual sprinkler was highly affected by operating pressure.

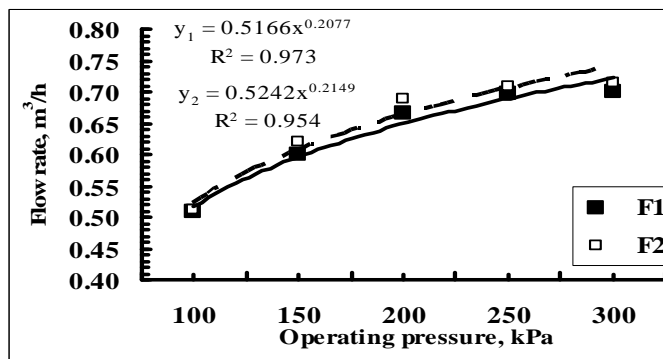

Figure 3: Relationship between operating pressure and flow rate for two types of floppy sprinkler, within the tested domain.

The application rate increased with increasing operating pressure under the same riser height. Meanwhile, the application rate decreased with increasing of riser height as shown in Table 2. The application rate

increased by 12.34 % and 18.94 % for  $F_1$  and  $F_2$ , respectively, when the operating pressure increased from 100 to 300 kPa at riser height of 1.0 m. Similar trend was observed for riser heights of 1.5, 2.0 and 2.5 m. The application rate decreased by 18.51 % and 9.25 % by increasing riser heights from 1.0 to 2.5 m at operating pressure 100 kPa for  $F_1$  and  $F_2$ , meanwhile decreased by 24.04 % and 17.04 % for  $F_1$  and  $F_2$ , respectively at operating pressure 300 kPa. Based on the obtained results, it can be seen that the high application rate could be achieved by combination of high operating pressure with low riser height for the two types of floppy sprinkler,  $F_1$  and  $F_2$ , respectively.

Table 2: Average of application rate under different levels of operating pressure and riser height for floppy sprinkler original type ( $F_1$ ) and local type ( $F_2$ ).

Type of floppy sprinkler	Operating pressure (kPa)	Application rate (mm/h)			
		Riser height (m)			
		1.0	1.5	2.0	2.5
Original type ( $F_1$ )	100	4.70	4.21	3.77	3.83
	150	5.04	4.57	4.05	3.85
	200	5.19	4.74	4.15	3.96
	250	5.27	4.87	4.16	3.97
	300	5.28	4.90	4.18	4.01
Local type ( $F_2$ )	100	4.54	4.32	4.25	4.12
	150	5.21	4.80	4.44	4.25
	200	5.35	4.96	4.51	4.38
	250	5.36	4.97	4.54	4.46
	300	5.40	5.00	4.57	4.48

### **Water application uniformity**

The uniformity of application is considered as a primary concern in the sprinkler irrigation design procedure. The coefficient of uniformity, distribution uniformity and application efficiency of low quarter were determined at different levels of riser height and operating pressure. Figure 4, 5 and 6 show the relationship between coefficient of uniformity,



distribution uniformity, application efficiency of low quarter and operating pressure at different levels of riser height.

In general, for all tested operating pressures and riser heights, the *CU* increased with increased operating pressure until its maximum at 200 kPa, but the operating pressure higher than 200 kPa, the *CU* decreased again. It can be seen that increasing of operating pressure from 100 to 200 kPa at riser height 2.0 m, the *CU* values increase from 58.17 % to 70.65 % for  $F_1$  and from 56.86 % to 66.67 % for  $F_2$ , respectively. In contract, when the operating pressure increased from 200 to 300 kPa, the *CU* values decreased from 70.65 % to 61.25 % and from 66.67 % to 58.80 % for floppy sprinkler  $F_1$  and  $F_2$ , respectively at the riser height 2.0 m. Also, the values of *CU* at the same operating pressure increased when the riser height increases from 1.0 to 2.0 m and decreased at the riser height of 2.5 m. In addition, it is clear that the coefficient of uniformity (*CU*) was affected by riser height of sprinkler too.

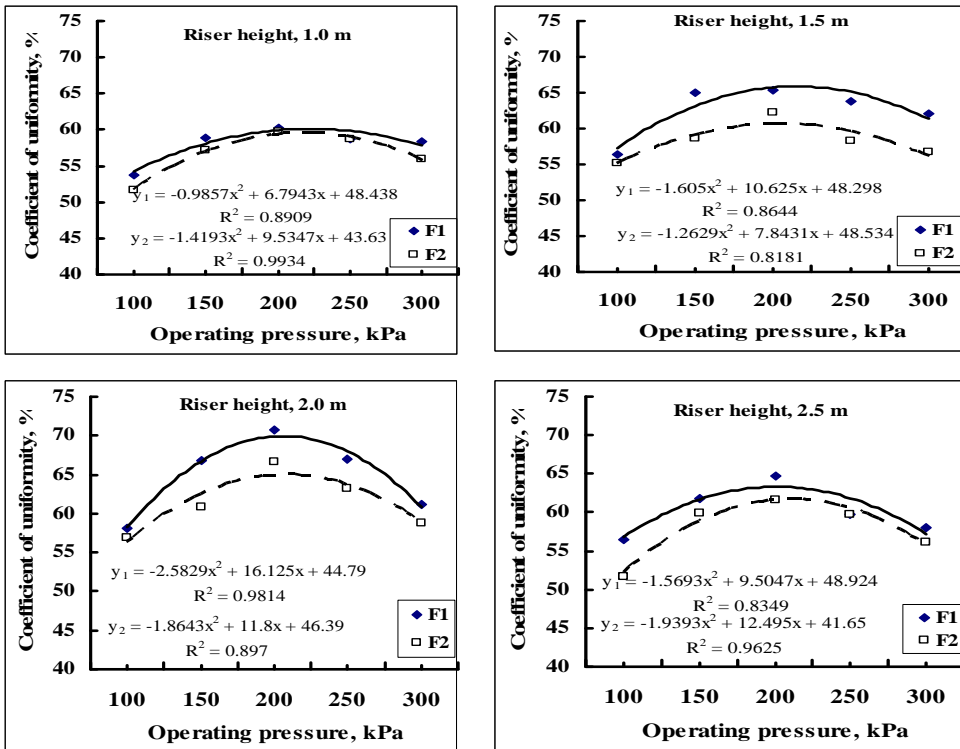

Figure 4: Relationship between operating pressure and coefficient of uniformity at different levels of riser height for the two types of

floppy sprinkler, within the tested pressures.

At the operating pressure 200 kPa, it was found that when riser height increased from 1.0 to 2.0 m, the  $CU$  increased from 60.24 % to 70.65 % for  $F_1$  and from 59.65 % to 66.67 % for  $F_2$ . On the other hand, when the riser height increases from 2.0 to 2.5 m, the values of  $CU$  decreased from 70.65 % to 64.71 % and from 66.67 % to 61.60 % for  $F_1$  and  $F_2$ , respectively. The decreased of the coefficient of uniformity with increase of riser height could be due to evaporative effect and drift of water drops.

When operating pressure were increased from 100 to 200 kPa at riser height 2.0 m, the  $DU$  values increase from 37.76 to 52.59 % for  $F_1$  and from 33.62 to 44.31 % for  $F_2$ . Meanwhile, the operating pressure increased from 200 to 300 kPa, and  $DU$  values decreased from 52.59 to 39.84 % and from 44.31 to 35.13 % for floppy sprinkler  $F_1$  and  $F_2$ , respectively at the riser height 2.0 m are presented in Figure 5.

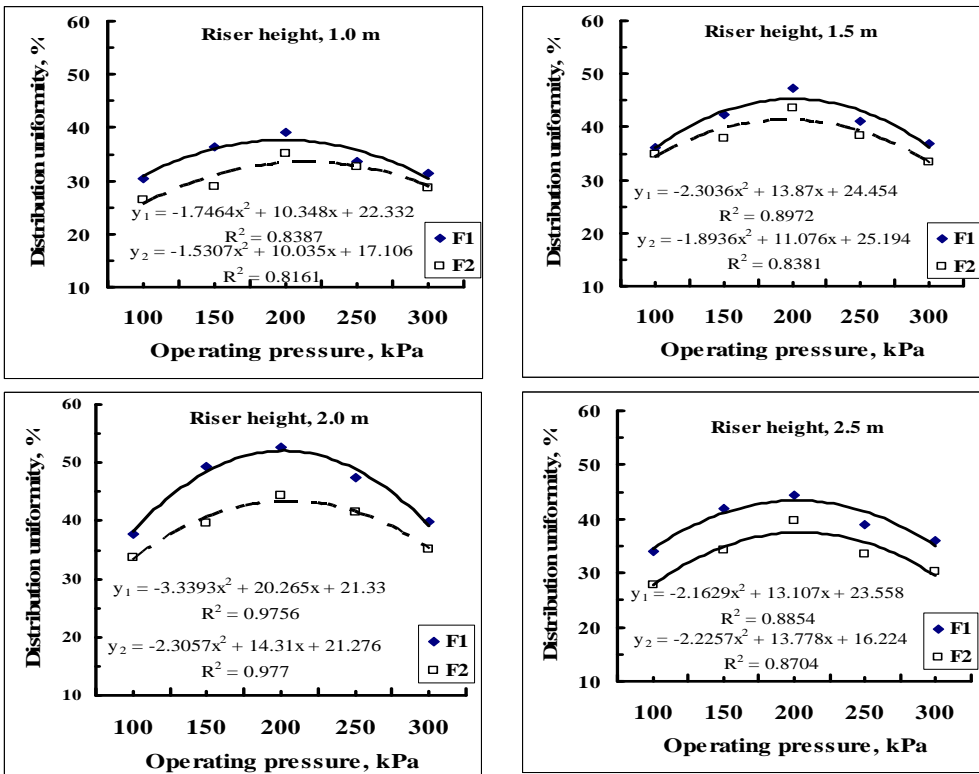

Figure 5: Relationship between operating pressure and distribution uniformity at different levels of riser height for the two types of floppy sprinkler within the tested data.

Also, the values of  $DU$  at the same operating pressure increased when the riser height increases from 1.0 to 2.0 m and decreased at the riser height of 2.5 m. At the operating pressure of 200 kPa, the values of  $DU$  were 39.09, 47.29, 52.59 and 44.51 % for  $F_1$  sprinkler and were 39.22, 43.56, 44.31 and 39.69 % for  $F_2$  sprinkler at riser heights of 1.0, 1.5, 2.0 and 2.5 m, respectively.

The values of application efficiency of low quarter ( $AELQ$ ) at different levels of operating pressure and riser height of  $F_1$  and  $F_2$  are presented in Figure 6.

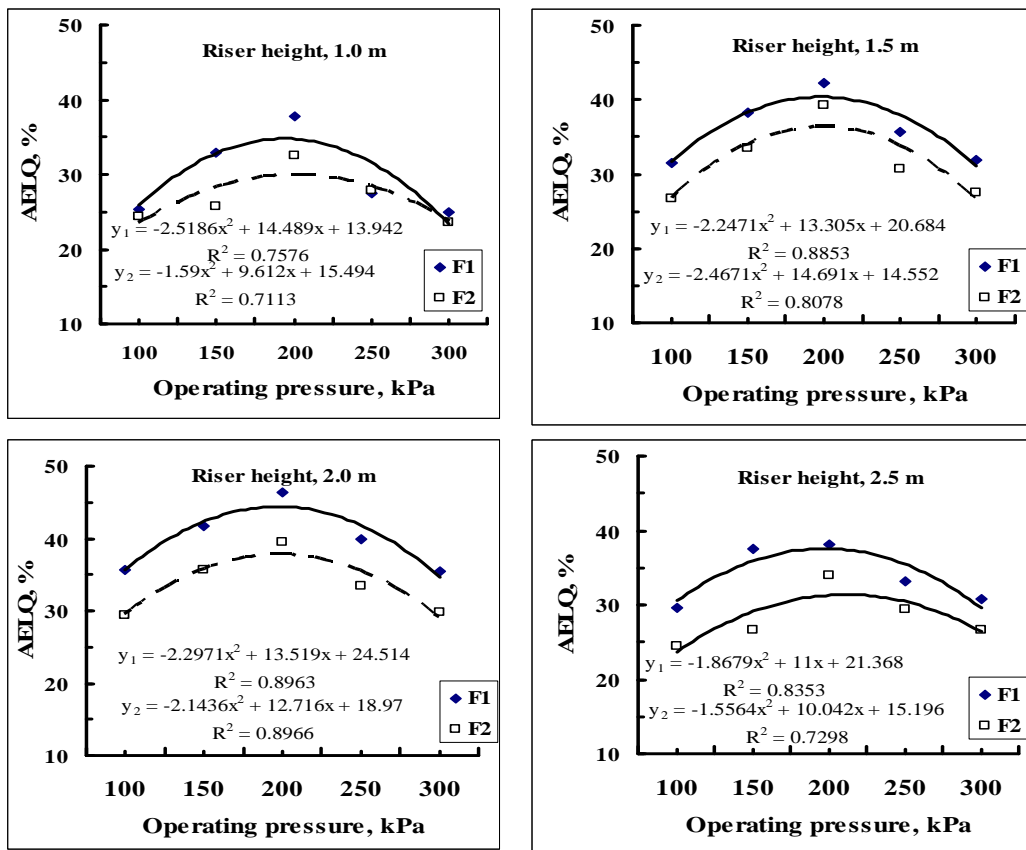

Figure 6: Relationship between operating pressure and application efficiency of low quarter at different levels of riser height for the two types of floppy sprinkler within the tested pressures.

When operating pressure increased from 100 to 200 kPa, the *AELQ* values increased from 35.69 to 46.33 % and from 29.34 to 39.46 % for  $F_1$  and  $F_2$ , respectively. Meanwhile, when the operating pressure was increased from 200 to 300 kPa at the riser heights of 2.0 m the *AELQ* values decreased from 46.33 to 35.37 % and from 39.46 to 29.71 % for  $F_1$  and  $F_2$ , respectively. The same trend was found for riser heights of 1.0, 1.5 and 2.5 m, but with different values. In addition, the increases of riser height from 1.0 to 2.0 m lead the *AELQ* to be increased from 37.84 to 46.33 % for  $F_1$  and from 32.45 to 39.46 % for  $F_2$ , respectively. However, when the riser heights increase from 2.0 to 2.5 m at operating pressure of 200 kPa the values of *AELQ* decreased from 46.33 to 38.12 % and from 39.46 to 33.94 for  $F_1$  and  $F_2$ , respectively. The same trend was found for operating pressures of 100, 150, 250 and 300 kPa, but with different values.

The decrease of coefficient of uniformity, distribution uniformity and application efficiency of low quarter at low and high operating pressures may be due to non-uniform water distribution. Thus, at low operating pressure level, the water jet did not break up easily and large water drops were formed and fall close to the sprinkler and sprinkler throw was reduced. Also, at high operating pressure level, the jet broke up too much and small water drops were produced which were easily to be blown and threw away from the sprinkler.

The results indicated that, there is a parallel trend of *CU*, *DU* and *AELQ* the highest values of *CU*, *DU* and *AELQ* were achieved with operating pressure of 200 kPa and riser height of 2.0 m. This means that the more improved water application uniformity could be achieved under previously mentioned operating pressure and riser height. Also, the  $F_1$  sprinkler improved water application uniformity compared with  $F_2$  under all tested levels of operating pressure and riser height. Thus may be due to the manufacturing reliability of  $F_1$  sprinkler.

## Optimization of water distribution uniformity for floppy sprinkler

The spacing of spray sprinkler is a limited factor to design the sprinkler systems. Therefore, it is relevant to predict sprinkler spacing that achieves optimum water distribution. Distribution uniformity ( $DU$ ) is considered as a basic indicator for water application uniformity for each sprinkler and it is affected by overlapping between sprinklers. The experimental data related to  $F_1$  and  $F_2$  sprinklers were simulated using computer software (Catch-3D) and (SURFER program) at operating pressure ranged from 100 kPa to 300 kPa, riser height ranged from 1.0 m to 2.5m, overlap percentage ranged from 30 % to 100 % and wind speed ranged from 0.31 to 1.83  $m\ s^{-1}$ .

It is clear that the overlapping improved water distribution uniformity. The  $DU$  for individual at operating of 200 kPa and riser height of 2.0 m, sprinkler were 52.59 % and 44.31 % and the corresponding values at overlap percentage 60 % were 77.90 % and 76.10 % for  $F_1$  and  $F_2$  sprinkler, respectively as shown in Figures (9 and 10). This means that the overlapping improved distribution uniformity by 25.31 % and 31.79 % for  $F_1$  and  $F_2$ , respectively.

The highest values of  $DU$  for  $F_1$  and  $F_2$  sprinkler were achieved at overlap percentage 60 % and operating pressure of 200 kPa, the  $DU$  values were 77.90 % for  $F_1$  and 76.10 % for  $F_2$  at riser height of 2.0 m respectively. This means that the  $DU$  was in excellent according to **ITRC (1991)** and **Schwankl et al. (2003)** for  $F_1$  and  $F_2$  at overlapped percentage of 60 %.

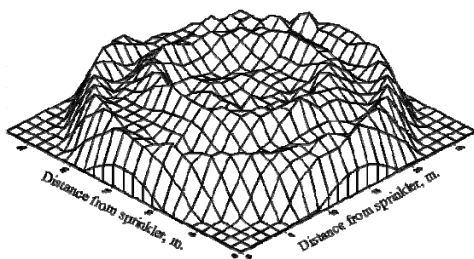

$DU = 52.59\%$

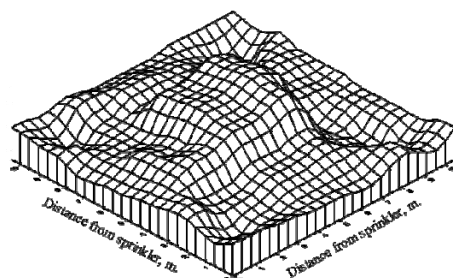

$DU = 77.90\%$

a - Original data from a single sprinkler. b - Overlap pattern for 60 %

(Simulated).

Figure 9: Water distribution profiles at operating pressure 200 kPa and riser height of 2.0 m for floppy sprinkler ( $F_1$ )

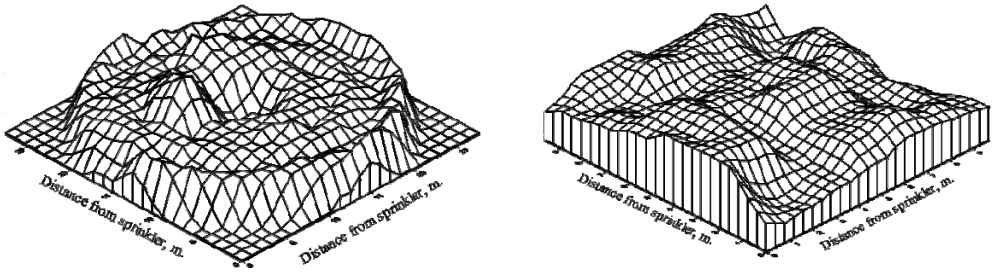

$DU = 44.31 \%$

a - Original data from a single sprinkler.

$DU = 76.10 \%$

b - Overlap pattern for 60 %

(Simulated).

Figure 10: Water distribution profiles at operating pressure 200 kPa and riser height of 2.0 m for floppy sprinkler ( $F_2$ ).

### CONCLUSION

It has been concluded that the performance of two types of floppy sprinklers, original and local was affected by operating pressures and riser heights. The results led to the following concluded points.

- 1- Flow rate and application rate were increased by increasing operating pressure for both types floppy sprinklers, is it need more energy.
- 2- The high of water distribution uniformity was achieved at operating pressure of 200 kPa and riser height of 2.0 m of floppy sprinkler
- 3- The values of distribution uniformity for original sprinkler are higher than the values of at the same conditions of operating pressures and riser heights.
- 4- Optimal spacing between sprinklers was found to be overlap percentage 60 % from wetted diameter for floppy sprinkler (Simulated data).

Based on the obtained results we concluded that, the high performance of floppy sprinkler can be achieved at operating pressure of 200 kPa and riser height of 2.0 m.

## **REFERENCES**

- Aboamera, M. and H. Sourell (2003).** Characteristics of water distribution and irrigation intensity for floppy sprinklers. The 11<sup>th</sup> Annual Conference of Misr Society of Agricultural Engineering, Egypt, 15-16 Oct., 20(4): 937 - 948.
- Abo-Ghobar, M. A. (2003).** A study on selecting the proper applied water under different irrigation systems. Misr Journal of Agricultural Engineering, Egypt, 20(3): 320 - 327.
- Allen, R. G. (1992).** Catch 3D-software sprinkler-pattern overlap program, Version 4.60. Biological and Irrigation Engineering Department, Utah State University, Logan, Man. PP: 16.
- Amer, K. H. (2006).** Water distribution uniformity as affected by sprinkler performance. Misr Journal of Agricultural Engineering, Egypt, 23(1): 82 - 95.
- ASAE Standard (2001).** Procedure for sprinkler testing and performance reporting. ASAE, Standard S398.1 JAN01: 880 - 882.
- Ascough, G. W. and G. A. Kiker (2002).** The effect of irrigation uniformity on irrigation water requirements. Water SA, 28(2): 235 - 241.
- Badr, A. E. (1992).** Water distribution from different sprinkler arrangements and its effect on yield (under fixed sprinkler irrigation system). Misr Journal of Agricultural Engineering, Egypt, 9(3): 398 - 419.
- Christiansen, J. E. (1942).** Irrigation by sprinkler. Bulletin 670. California Agricultural Experiment Station. University of California. Berkeley, California.
- Dukes, M. D. and C. Perry (2006).** Uniformity testing of variable-rate center pivot irrigation control systems. Precision Agriculture, 7(3): 205 - 218. (Agricultural Engineering Abstract).
- El-Ansary, M. Y.; A. M. El-Gindy; M. A. Awad and E. A. Wasif (2003).** Evaluation of the alternate sets management of sprinkler irrigation. The 11<sup>th</sup>

- Annual Conference of Misr Society of Agricultural Engineering, Egypt, 15-16 Oct., 20(4): 236 - 250.
- El-Sherbeni, A. M. (1994).** Design of sprinkler and drip irrigation systems in newly reclaimed soils. Ph. D. Thesis in Agricultural Engineering, Faculty of Agriculture, Zagazig University, Egypt, PP: 141.
- Golden Software (2000).** Contouring and 3D-surface mapping for scientists and engineers Version 7. Golden Software, [Inc., www. goldensoftware.com.](http://www.goldensoftware.com)
- Griffiths, B. A. K. and N. L. Lecler (2001).** Irrigation system evaluation. Proceeding of the Annual Congress South African Sugar Technologists Association, 75: 58 - 67.
- Heermann, D. F.; W. W. Wallender and G. M. Bos (1990).** Irrigation efficiency and uniformity. (C. F. Hoffman, G. J., Howell, T. A., Solomon, K. H. (Eds.), Management of Farm Irrigation Systems. ASAE, St. Joseph, MI. 125 - 149).
- Ismail, E. E. (1995).** Field performance of a simplified wheel-mounted sprinkler lateral. Misr Journal of Agricultural Engineering, Egypt, 12(2): 321 - 333.
- Ismail, S. M. (1985).** Water distribution under low pressure-center pivot sprinkler irrigation system. Misr Journal of Agricultural Engineering, Egypt, 2(4): 81 - 96.
- ITRC (1991).** Landscape water management principles, Version 1.01, Irrigation Training and Research Center, Cal Poly State University, San Luis Obispo, California: 140P. (C.f. **El Awad, M. N.; E. G. Vis.; R. Kumar and S. Mitra (2003).** Distribution uniformity from pop-up sprinklers and landscape water-saving. The 11<sup>th</sup> Annual Conference of Misr Society of Agricultural Engineering, Egypt, 15 - 16 Oct.: 181 - 194).
- James, L. G. (1988).** Principles of farm irrigation system design. New York: John Wiley and Sons. PP: 545.
- Keller, J. and R. D. Bliesner (1990).** Sprinkler and trickle irrigation. Van Nostrand, Reinhold, New York. PP: 643.
- Melvyn, K. (1983).** Sprinkler irrigation, equipment and practice. Batsford Academic and Educational, London. PP: 120.
- Merriam, J. L. and J. Keller (1978).** Farm irrigation system evaluation. A guide for management. Logan, Utah: Agricultural and Irrigation Engineering Department, Utah State University.



**Schwankl, L. J.; D. A. Shaw; M. A. Harivandi and R. L. Snyder (2003).**  
Evaluating turfgrass sprinkler irrigation system, Coop. Ext., University of  
California, Division Agricultural and Nat. Resources, Leaflet 21503: 18p.

**Tarjuelo, J. M.; J. Montero; F. T. Honrubia; J. J. Ortiz and J. F. Ortega  
(1999).** Analysis of uniformity of sprinkler irrigation in a semi-arid area.  
Agricultural Water Management, USA, 40: 315 - 331.

#### الملخص العربي

#### تقييم أداء الرشاش المرن

أ. د. عادل سالم السيد\* أ. د. محمود محمد حجازي\*\* د. إسلام حسن الشيخ\* م. أحمد فتحى خضر\*

الهدف الأساسى لهذا البحث تقييم أداء نوعين من الرشاش المرن. حيث تم إنشاء وحدة إختبار تجريبية بمزرعة كلية الزراعة جامعة قناة السويس بالإسماعيلية. وتم دراسة إنتظامية توزيع المياه للرشاش المرن المستورد والمصنع محلى تحت تأثير ضغوط تشغيل (100، 150، 200، 250، 300 ك باسكال)، و ارتفاعات رأس الرشاش (1.0، 1.5، 2.0، 2.5م). أظهرت النتائج أن أعلى قيم لمعامل إنتظامية التوزيع  $CU$ ، كفاءة إنتظامية التوزيع  $DU$ ، وكفاءة إضافة المياه  $AELQ$  تم الحصول عليهما للرشاش المرن المستورد  $F_1$  كانت 70.65 %، 52.59 %، 44.33 % والرشاش المرن المحلى  $F_2$  وصلت إلى 66.67 %، 44.31 %، 37.46 % على ارتفاع 2.0 م و ضغط تشغيل 200 ك باسكال على التوالي.

و يوصى بتشغيل الرشاش المرن عند ضغط تشغيل 200 ك باسكال، ارتفاع رأس الرشاش 2.0 م للحصول على أعلى قيمة لمعامل إنتظامية التوزيع، كفاءة إنتظامية التوزيع، وكفاءة إضافة المياه. و للحصول على نسبة تداخل لتحديد البعد المناسب بين الرشاشات و تم تمثيل البيانات الفردية للرشاش على الحاسب الآلى و اظهرت أنه يجب أن تكون  $\leq 50\%$  من قطر الإبتلال وذلك لتقليل فقد المياه و تكاليف نظام الرى بالرش وذلك لزيادة معدل الرش عن معدل تسرب التربة وتقليل تكاليف النظام.

\* أستاذ الهندسة الزراعية - قسم الهندسة الزراعية - كلية الزراعة - جامعة قناة السويس.

\*\* أستاذ الهندسة الزراعية - قسم الهندسة الزراعية - كلية الزراعة - جامعة عين شمس.

\* مدرس- قسم الهندسة الزراعية - كلية الزراعة - جامعة قناة السويس.

\* معيد- قسم الهندسة الزراعية - كلية الزراعة - جامعة قناة السويس.