

FILTERS AND EMITTERS PERFORMANCE UNDER TREATED WASTEWATER

*EI-Tantawy M.T. *Matter M.A. **Arafa Y. E.

ABSTRACT

The experiment was carried out under open field conditions in sandy soil at Ismailia Wastewater Treatment Plant in “Sarapeum” to study the field performance under different quality of wastewater on different types of emitter's performance to irrigate woody trees. The filtration units consist of gravel filter followed by disk filter. The present study included twelve treatments which represented the combination between two treatments of wastewater (A) (with different organic and chemical concentrations), two emitters (B) (inline and online) and three times of operation (C) (0.0, 50.0 and 100 h). The measured data included organic mater such as BOD₅ (mg/l) and TSS (mg/l) and chemical such as Ca⁺⁺ and Mg⁺⁺, partial and total clogging emitters percentage. The collected data were analyzed by using MSTATc program, in a split split plot design with three replications.

The results show that on-line emitter is better than in-line emitters. In-line emitters were more sensitive to clogging than on-line in partial and total percentages of emitters clogging were found. A significant difference due to increasing concentration of wastewater organic materials such as BOD₅ and TSS mg/l and some chemical analysis such as Calcium and Magnesium content .

The gravel media filter followed by the disk filter gave better performance in T1 than T2 after 100 h of operation time respectively due to increasing for organic and chemical matters in the treated wastewater. The partial clogging percentages of gravel filter in T2 more than in T1 by ratios 14.6 % and in disk filter 11.3 %, and the mean discharge reduction percentages 4.3 % in gravel filter and 3.2 % in screen filter. Emitters emission uniformity percentage in T1 better than T2 especially in online and inline emitters and especially in on line emitters The highest mean manual operation and lowest back flushing operation was recorded in disk filters due to low concentration of BOD₅ (mg/O₂) and TSS (mg/l) in T1 compared with T2.

Keywords: Drip irrigation, Treated wastewater and Water quality

*Ag. Eng. Res. Inst., Ag. Res. Center, MALR

** Ag. Eng. Dept., Faculty of Agriculture, Ain Shams University

INTRODUCTION

Agriculture is the main user of water in Egypt, where it is more difficult to meet the agricultural water demand with conventional resources, using treated wastewater represents a viable option. **Capra and Scicolone, (1998)** mentioned that clogging and mitigation procedures are closely related to the quality of the water used. When wastewater is used, clogging problems depend on treatment level and on high temporal variability (time of day, season, etc.). Suspended solids and organic matter content can cause emitter clogging **Barbagallo et al. (2002)** discourage wastewater reuse by drip systems, mainly in southern areas where, advanced wastewater treatment is not used. Farm water treatment systems are generally very elementary (screen filters only on most farms) and irrigators prefer large-sized emitters such as sprayers and sprinklers. At present, analytical methods to forecast the clogging risk do not exist. Very little information is available for clean water. **Nakayama and Bucks (1991)** classified the clogging risk for common drippers (discharge from 2 or 4 L h⁻¹ at an operating pressure of 101.2 kPa). The water quality parameters taken into account such as suspended solids, dissolved solids, pH, manganese, total iron, hydrogen sulfide and number of bacteria; **Boswell (1993)** uses manganese, total iron and hydrogen sulfide; and **Capra and Scicolone (1998)** take into account the same factors as **Nakayama and Bucks (1991)**, plus calcium and magnesium. All authors classify the hazard rating in three classes: minor, moderate and severe. A temporary classification of the emitters clogging according to BOD₅, to be classified as follow: low when BOD₅ is <15 mg l⁻¹ of O₂, medium between 15 and 40 mg l⁻¹, and high >40 mg l⁻¹. The values are calculated as the mean of a minimum of four samples analyzed during each treatment (at the start, in the middle and at the end of the treatment). The emitters range was evaluated according to the classification **Keller and Bliesner (1990)** classified the total physical suspended solids (TSS) in irrigation water used in trickle irrigation system as follow: low when TSS <50 ppm medium 50-100 ppm, and high >100. The clogging of drip emitters is the largest maintenance problem with drip systems It is difficult to detect and expensive to clean, or replace clogged emitters. Partial or complete

clogging reduces emission uniformity and, therefore, decreases irrigation efficiency. In many cases, to assure that irrigated plants receive their water requirement, it is necessary to put up with water loss due to over irrigation. Disk filters also are simple and economical, but they have only recently been introduced. Gravel-sand media filters are particularly suitable for water with high-suspended solids content, but they are more complex and expensive. **Ravina et al. (1992)** said that the clogging process generally started with emitters located at the far end of the lateral and partial emitter clogging was more common than complete plugging. Overflow was also found in most emitter types and was more common in regulated emitters. **Bahri (1999)** used treated wastewater to irrigate a variety of field crops and orchards and intensive effort was being made to expand crops that can be irrigated with wastewater. **Friedler, (2001)** reported that in Israel wastewater irrigation uses more than 65% of the total municipal sewage production of the country. **Al-Jamal et al. (2002)** said that the effective solution for both needs is the reuse of municipal effluents for irrigation. Wastewater has been applied to crops, rangelands, forests, parks and golf courses in many parts of the world. **El-Berry et al. 2003** mentioned that the granular foam media was more efficient in the removal efficiency such as TSS mg/L, VSS mg/L, BOD₅ mg/L, F. coliform N/100 ml and chlor (A) with increasing by percentages of 16.2, 20.8, 2.7, 18.5, and 6.1 respectively than those of the crushed one, with head losses of 0.3 bar. The all hydraulic parameters (flow rate reduction percentage, time consumed for filtering cubic meter, mean flow rate and filtration cycle time related to removal efficiency were in general better in granular media under different inlet pressures (2.0 bar and 1.0 bar) and those under 2.0 bar inlet operating pressure were better than those under 1.0 bar. **Capra and Scicolone (2004)** mentioned that the existing clogging risk classifications proposed for clean water could only be considered reliable for wastewater when labyrinth emitters and gravel or good quality disk filters are used. They are not adequate for vortex emitters or screen filters.

The aim of this research was to determine the effect of different qualities of treated wastewater on performance of different types of filters and emitters.

MATERIALS AND METHODS

The experiment was carried out under open field conditions in sandy soil at Ismailia Wastewater Treatment Plant in “Sarapeum” to study the field performance under different quality of wastewater on different types of emitter's performance. The filtration units consist of gravel filter followed by disk filter. The present study included twelve treatments which represented the combination between two treatments of wastewater (A) (with different organic and chemical concentrations), two emitters (B) (inline and online) and three times of operation (C) (0.0, 50.0 and 100 h). The measured data included organic mater such as BOD5 (mg/l) and TSS (mg/l) and chemical such as Ca and Mg, partial and total clogging emitters percentage. The collected data were analyzed by using MSTATc program, in a split split plot design with three replications.

The values of some chemical and organic analysis of the two-treated wastewater as analyzed in laboratory at Ismailia Wastewater Treatment Plant in “Sarapeum” are presented in table 1 and 2.

Table (1): Some chemical analysis of wastewater treatments (secondary stage).

Treatments	pH	EC dS/m	Soluble Cations meq/l,				Soluble Anions, meq/l			
			Ca ⁺⁺	Mg ⁺⁺	Na ⁺	K ⁺	CO ₃ ⁻	HCO ₃ ⁻	SO ₄ ⁻⁻	Cl ⁻
T (1)	7.8	1.65	9.2	7.10	0.3	0.9	-	2.60	9.90	4.0
T (2)	7.9	1.75	9.3	7.20	0.5	0.5	-	2.70	11.80	3.0

Table (2): Some organic analysis of two types of treated wastewater.

Treatments	BOD ₅ mg/l	TSS mg/l	VSS mg/l	TDS mg/l	Chlor. A mg/l	F. Coliform No/ 100 ml
T (1)	65.9	105.2	25.3	560	0.32	59376
T (2)	103	196.31	30.8	585	0.35	119478

*(BOD₅): The biological oxygen demand,

*VSS: Volatile suspended solids ,

*Chlor.A.: Chlorophyll,

*TSS: Total suspended solids,

*TDS: Total dissolved solids.

*F. Coliform: Fical Coliform

In surface drip irrigation system two emitter local types fitted in and on

laterals polyethylene pipe of O.D.= 20 mm under operating pressure, H=101.2 kPa the specifications of tested emitters in National Irrigation Lab, ARC, Dokki, Giza is shown in table (3). Table (4) shows the specifications of the gravel and disk filters.

Table (3): Hydraulic characteristics of the two emitter types.

Types of Emitters	Emitters discharge (L h ⁻¹)	Emitters discharge exponent (x)	Emitters manufacture coefficient of variation (C.V.)	Type of Emitters discharge
On line	3.9	0.4272	4.55	Turbulent
In line	3.99	0.453	4.3	Turbulent

Table (4): Specifications of the gravel and disk filters.

- Specifications	Gravel filters	Disk filter
-Number of filters	2	2
-Recommended maximum flow rate (m ³ h ⁻¹).	18	30
-Maximum operating pressure (bar).	10	5
-Filtration capacity (m. ³ m ⁻² h ⁻¹).	53.1	-
-Inlet and outlet diameters (inch).	2	3
-Length (mm).	1100	60
-Tank diameter (mm).	500	25
-Wall Thickness (mm).	5.0	3
-Thickness of media layers (mm).	600	-
-Back washing diameter (inch).	2	-
-Up drain types.	cylindrical	-
-Up drain diameter (inch).	2	-
<u>Specification of media</u>		
- Bed area (m. ²)	0.952	
-Effective diameter of granular media (mm).	1.0-1.5	

The disk filter used with diameter 3 inch, 120 mesh and maximum flow rate 30 m³ h⁻¹

Experimental design

The present study included twelve treatments represented the combination between 2 treatments of wastewater (with different concentrations of organic and chemical), 2 emitters (inline and online) and 3 times of operation (0.0, 50.0 and 100 h) to analyze irrigation water some organic mater such as BOD₅ (mg/l) and TSS (mg/l) and chemical such as Ca , Mg , partial and total clogging emitters percentage. The collected data were analyzed, using MSTATc program, in a split plot

design with three replication. Two different types of filters Gravel and disk filters and two types of emitters inline and online were tested. The treatments layout consisted of a flow meter, two pressure gauges installed before and after each filter and three polyethylene lateral lines two for each type of emitters. Lateral line was 40 m long and had 80 emitters connected at a spacing of 0.5 m. The external diameters (O.D) of the laterals were 20 mm with wall thickness 1.2 mm. During each treatment, the system was in operation for about 100 h with daily operation (4h). On each day of operation and for each type of filter, the exact time of operation, the total flow volume, clogged emitter's percentage partially and totally were recorded. The numbers of filter cleaning operations were recorded. Because the head loss in lateral lines was very small, the pressure along the lateral can be considered essentially constant. Each filter type was doubled and connected in parallel to allow it to continue operating during cleaning (one filter was operating while the other was being cleaned). The filters were cleaned by back flushing whenever the pressure drop caused by partial clogging of the filter increased to 20.24 kPa (Keller and Bliesner, 1990). Disk filters were also manually cleaned, by pulling out the filter disks and washing it. All types of filters were manually cleaned and dried at the end of each day of operation.

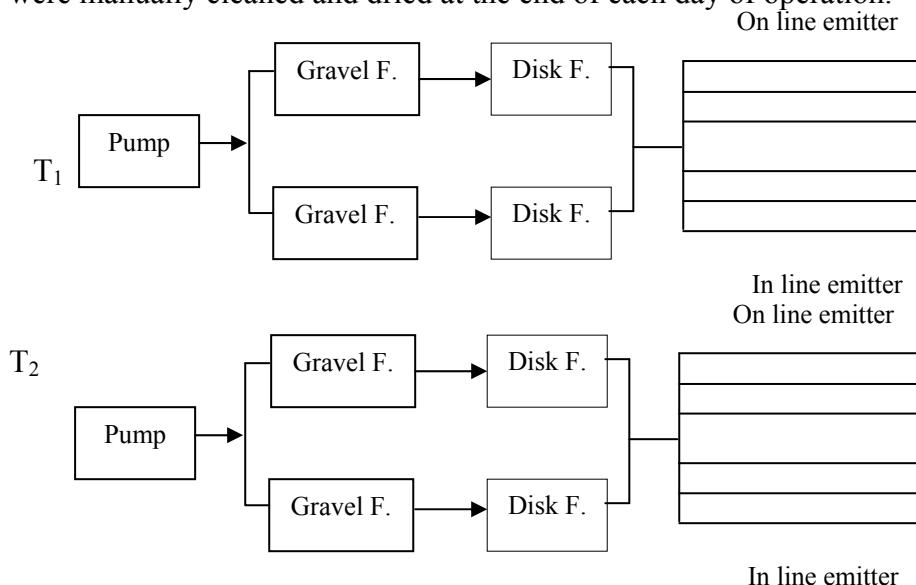

Fig. (1): Lay out of experiment.

Assessment of emitter performance:

- The reduction of mean discharge R_d (%).

The partial clogging of the emitters was calculated as follows:

$$R_d = (1 - Q_m / Q_t) 100 \dots\dots\dots (1)$$

Where: Q_m is the measured mean discharge of last operation ($m^3 h^{-1}$) and Q_t the discharge of 400 new, unclogged emitters at the same operating pressure ($m^3 h^{-1}$).

-Manufacturer's variation (CVm).

The manufacturer's coefficient of emitter's variation is a measure of the variability of discharge of a random sample of a given make, model and size of emitter as produced by the manufacturer and before any field operation or aging has taken place (ASAE 1996). The manufacturer's coefficient of emitter's variation (CVm) is defined as follows:

$$CVm = s/q_a \dots\dots\dots (2)$$

Where

CVm = the manufacturer's coefficient of emitter's variation,
 s= standard deviation of emitter discharges rates at a reference pressure head.

q_a = average flow rate of emitters at that reference pressure head (lh^{-1})

The manufacturer's variation is mainly caused by pressure and heat instability during emitter production. In addition, a high CVm could occur due to a heterogeneous mixture of the materials used in the production of emitters. Typical values for CVm range from 2.0 to 15 %, although higher are possible (Boswell, 1985). Classification of (CVm) values according to ASAE standers are shown in table (6).

Table (6): ASAE recommended classification of emitter manufacture coefficient of variation " CV_m ".

Classifications	Excellent	Average	Marginal	Poor	unacceptable
CVm (%)	<5.0	5.0 – 7.0	7.0 - 11.0	11.0 – 15.0	>15.0

The emitter manufacture coefficient of variation " CV_m " is one of the

statistical terms, which can be used to show the trickle irrigation system uniformity. Numerous guidelines have been suggested for "CV", but those recommended by (ASAE, 1996) include:

Field emission uniformity coefficient, EU (%),

At the end of treatments the discharge of 25 emitters discharges within an irrigation block and is shown by equation (4) for treatment was measured to estimate the field emission uniformity coefficient, EU (%). as follows :

$$EU = (q_{min} / q_a) 100 \dots\dots\dots (3)$$

Where:

- EU= the emission uniformity, %,
- q_{min}= measured mean of the lowest ¼ of the emitter discharge(l/h),
- q_a= measured mean of all emitter discharge(l/h).

Emitter Exponent

The emitter is the most important part of drip irrigation tubing. An emitter with a high degree of pressure compensating (x =0) is technically possible, although the ideal emitter has not yet been invented. Emitter flow rate may fluctuate as pressure along the lateral line varies due to friction, evaluation, and accidental restriction, resulting in a non- uniform water application (Braud and Soon, 1980).

Emitter discharge rate is a function of operating pressure as described in the power law

$$q = k H^x \dots\dots\dots (4)$$

Where:

- q= emitter discharge rate, l/h,
- k= emitter constant, including factors to make units constant,
- H= operating pressure (KPa), and x= emitter exponent.

For a fully laminar flow regime, emitters must be very sensitive to pressure head changes and the value of x must be 1.0. This means that a pressure variation of 20.0 % may result in ± 20.0% emitter flow rate variation. Most non compensating emitters are always fully turbulent with an x level of about 0.5, indicating that a pressure variation of approximately 10.0 %. On the other hand, for compensating emitter pressure variation causes little discharge variation. Compensating emitter

has an x level ranging from 0.1 to 0.4. An ideal pressure compensating emitter would have an x level equal to 0 (**Braud and Soon, 1980 and Boswell, 1985**). Equation (4) was utilized to calculate the x values in this study.

-Emitter flow rate variation (q_{var})

Emitter flow rate variation (q_{var}) (**Camp et al., 1997**).

$$q_{var} = \left(\frac{q_m - q_n}{q_n} \right) 100 \dots\dots\dots (5)$$

Where:

q_{var} = variation of the average flow rate from the nominal,(%),

q_m = average flow rate, (l/h),

q_n = nominal flow rate at pressure of 1.0 bar and the same water temperature.

RESULTS AND DISCUSSION

1- Water quality

The characteristics of wastewater used to evaluate the mean emitters clogging during time of operation (h) up to 100 hours are shown in tables (7 a & b) and (8). The previous results show a good correlation between the total suspended solids and the performance indices measured, whereas the organic matter content, expressed by BOD₅, is the worst correlated. A temporary classification of the emitters clogging ranged according to BOD₅, to be classified as follow: low when BOD₅ is <15 mg l⁻¹, medium between 15 and 40 mg l⁻¹, and high >40 mg l⁻¹. In table (7a), the water quality parameters that show the greatest difference between the wastewater used in the different treatments are total suspended solids and BOD₅. The difference between the two treatments of water and the two emitter types were insignificant. Otherwise the combination between all treatments were significantly different due to concentration of BOD₅ more than 40 mg/O₂ classified high according to **Nakayama and Bucks (1991)**. In case of total soluble solids TSS (mg/l), the combinations between all treatments were significantly different due to different concentration, which classified T1 (medium) and T2 (high) according to **Keller and Bliesner (1990)**. While the differences between emitter types time of operation, wastewater treatments, emitters types and times of

operation were insignificant in their different concentration of TSS, emitters types and wastewater treatments.

Table (7a) : The characteristics of wastewater used to evaluate the mean emitters clogging due to BOD₅ (mg/l) and TSS (mg/l).

Treat-ments	Emitters types	BOD5 mg/l				TSS mg/l			
		Time of operation (h)			Mean	Time of operation (h)			Mean
		0	50	100		0	50	100	
T1	In line	43.00	48.00	58.00	49.67	87.00	98.00	101.33	95.44
	On line	40.00	42.00	52.00	44.67	81.00	94.00	97.00	90.67
Mean		41.50	45.00	55.00	47.17	84.00	96.00	99.17	93.06
T2	In line	61.00	73.00	87.00	73.67	154.00	171.00	177.00	167.33
	On line	56.00	68.00	81.00	68.33	145.33	163.00	170.00	159.44
Mean		58.50	70.50	84.00	71.00	149.67	167.00	173.50	163.39
Mean	In line	52.00	60.50	72.50	61.67	120.50	134.50	139.17	131.39
	On line	48.00	55.00	56.50	56.50	113.17	128.50	133.50	125.06
Mean		50.00	57.75	69.50	59.08	116.83	131.50	136.33	128.22

L.S.D at 0.05 level
for:

A	0.83	1.10
B	0.47	0.72
C	0.58	0.88
AxB	N.S	1.02
AxC	0.82	1.25
BxC	0.82	N.S
AxBxC	1.16	N.S

In table (7b) the influence of some chemical analysis such as Ca⁺⁺ and Mg⁺⁺ (mg/l) in wastewater on emitters clogging were significantly different due to wastewater differences, emitters types, time of operation and combination between wastewater and operation time. While the combination difference between wastewater and emitters types, emitter's types and time of operation, wastewater, emitters types, and operation time were insignificant due to differs emitter types, wastewater types.

In table (8), the characteristics of wastewater used to evaluate the mean partial and total emitters clogging percentages. In case of partial emitters, clogging percentages, the differences between all treatment wastewater types, emitter's types and operation time were significant differences accept the combination differences between wastewater types and emitter types were insignificant in their influences on emitters partial clogging percentage.

Table (7 b): The characteristics of wastewater used to evaluate the mean emitters clogging due to Mg (mg/l) and Ca (mg/l)

Treat-ments	Emitters types	Mg ⁺⁺ (mg/l)				Ca ⁺⁺ (mg/l)			
		Time of operation (h)			Mean 50	Time of operation (h)			Mean
		00	50	100		00	50	100	
T1	In line	5.90	6.60	7.20	6.60	9.10	9.50	1.01	9.57
	On line	5.30	6.10	6.70	6.03	8.50	8.97	9.50	8.99
Mean		5.60	6.35	6.95	6.32	8.80	9.23	9.80	9.28
T2	In line	2.20	2.50	2.90	2.53	10.40	10.90	11.70	11.00
	On line	1.70	2.17	2.40	2.09	9.70	10.10	11.10	10.30
Mean		1.95	2.33	2.65	2.31	10.05	10.50	11.40	10.65
Mean of	In line	4.05	4.55	5.08	4.56	9.75	10.20	10.90	10.28
	On line	3.51	4.13	4.56	4.06	9.10	9.53	10.30	9.64
Mean		3.78	4.34	4.82	4.31	9.42	9.87	10.60	9.94

L.S.D at 0.05

A	1.81	1.86
B	0.82	0.88
C	1.00	1.08
AxB	N.S	N.S
AxC	1.42	1.52
BxC	N.S	N.S
AxBxC	N.S	N.S

Table (8): The effect of wastewater treatments and emitter types on partial and total clogging of emitters.

Treat-ments	Emitters types	Partial clogging %				Total clogging %			
		Time of operation (h)			Mean 50	Time of operation (h)			Mean 50
		00	50	100		00	50	100	
T1	In line	9.80	14.50	35.47	19.92	5.0	12.46	15.53	11.0
	On line	7.40	12.33	30.33	16.69	3.06	10.4	11.76	8.59
Mean		8.60	13.42	32.90	18.31	4.3	11.4	13.65	9.79
T2	In line	13.20	16.33	37.50	22.34	6.60	10.26	13.23	10.03
	On line	10.20	13.33	33.47	19.00	5.23	9.77	11.33	8.68
Mean		11.70	14.83	35.48	20.67	5.9	10.02	12.28	9.40
Mean	In line	11.50	15.42	36.48	21.13	5.8	11.37	14.38	10.16
	On line	8.80	12.83	31.90	17.84	4.4	10.08	11.55	8.68
Mean		10.15	14.13	34.19	19.49	5.1	10.73	12.97	9.6

L.S.D at 0.05

A	0.12	0.12
B	0.12	0.16
C	0.15	0.19
AxB	N.S	0.22
AxC	0.21	0.27
BxC	0.21	0.27
AxBxC	0.30	0.39

In case of total emitters, clogging percentages, the differences between all treatment wastewater types, emitter's types and operation time were significantly different except the combination differences between

wastewater types and emitter types were insignificant in their influences on partial emitters clogging percentage. The Partial and total of emitters were significantly different due to the different concentration of wastewater organic and chemical and effect on total emitters clogging. The results obtained that the on line emitters were better than in line emitters under different treatments were analyzed. The data given show low percentage of clogged emitters range especially in treatment (1) was medium than treatment 2 was high respectively.

In Fig.(2) represented the effect different treated wastewater treatments on partial filters clogging percentages (gravel and disk). The partial clogging percentages of gravel and disk filters ranged from 6.0 to 18.6 % and 4.0 to 15.6% in T1 and 10.0 to 33.2 %, and 8.0 to 26.9 % in T2 respectively due to increasing of organic matters and chemical contents in the treated wastewater. The partial clogging percentages of gravel filter in T2 more by ratios 14.6 % and in disk filter 11.3 % after time of operation 100 h respectively.

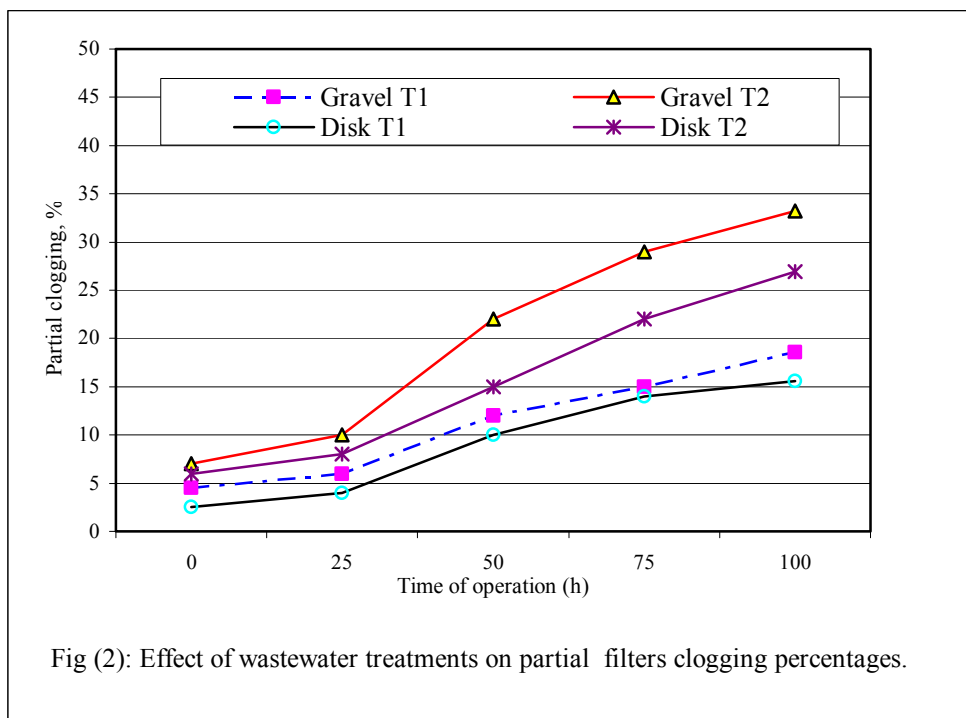

2- Mean discharge reduction percentages for different types of filters.

In Fig. (3) Show the reduction of the mean discharge percentages for different types of filters (gravel and disk filters) at start and end of the experiment during time of operation 100 h. The reduction of mean discharge percentages of gravel filter ranged from 9.4 to 31.2 % in T1 and 11.8 to 35.5 % in T2 due to increasing for organic matters and chemical contents in the treated wastewater. The partial clogging percentages of gravel filter in T2 more than in T1 by ratios 12.11 % and in disk filter 14.0 % after time of operation 100 h respectively.

That means increasing discharge reduction of filters increases filtration efficiency due to preventing organic and non-organic sedimentations in the treated wastewater and effects on clogged emitters. The clogged emitters range is not sufficient to account for the reduction in the mean discharge, so there must be problems of partial clogging as well. In fact, a certain discharge reduction was also observed in line emitters operating with wastewater filtered by gravel and disk filters.

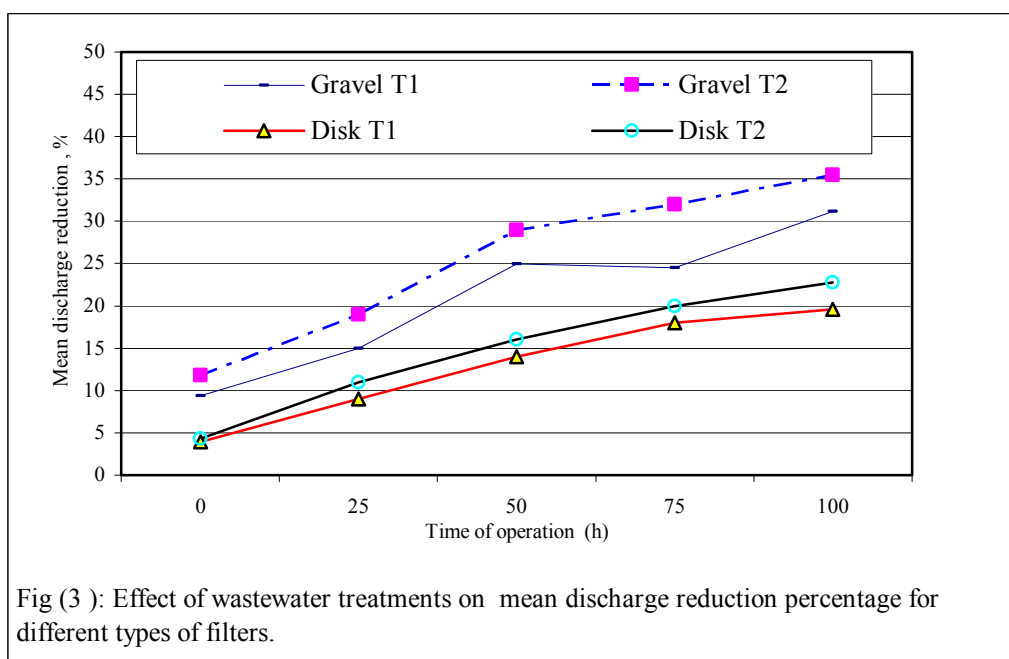

3- Field Emission uniformity coefficients EU (%)

Field Emission uniformity coefficients (%) measured at the end of four two wastewater treatments shows in Fig.(4). EU (%) classification is more than 90.0% (excellent), 80.0 - 90.0 % (good), 70.0 - 80.0 % (fair), 60.0-70.0% (poor) and less than 60.0 % unacceptable, (ASAE, 1996). Emission uniformity coefficient values equal to zero mean that at least one quarter of the emitters tested were completely clogged. In treatment (1) was generally better than treatment T2 in both inline and online emitters, and on line emitters better than in line emitters respectively. In T1, EU % were fair in both inline and online emitters until hours operating time ≤ 75 hours and ≤ 25 hours operating time respectively and more than were poor. While In T2, EU percentage was fair in both inline emitters until hours operating time ≤ 25 hours and poor in T2. The previous results showed increasing the total suspended solids and BOD₅ and chemical analysis in T2 more than T1 led to decreasing EU percentage

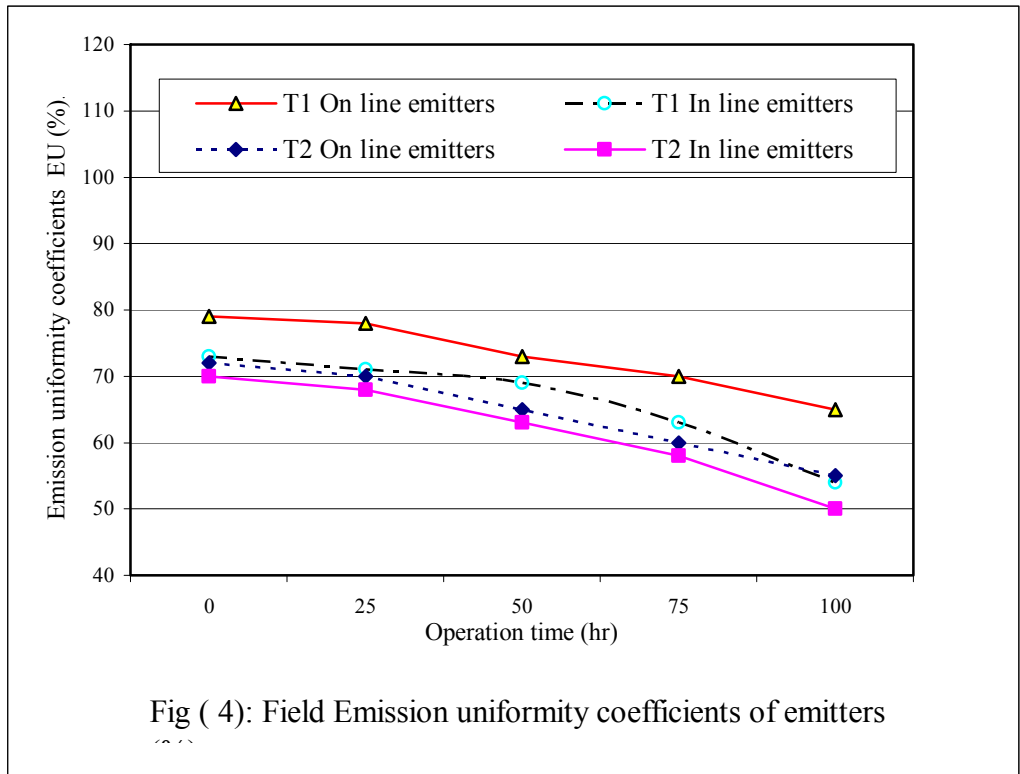

4- Mean manual operation and back flushing time of the filters

The duration of mean manual operation time (M) (min) between two successive back flushing operations (BF) is shown in Fig.(5), the operating time is clearly dependent on both the water quality and the type of filter. Treated wastewater especially in treatment (2) needed more back flushing time comparable to T1, that mean short operating times caused filtration problems. The manual operating time of the disk filter was longer with percentages 5.7 %, 8.33 % and lowest with percentages 50.0 %, 12.5 % back flushing time than the gravel filter in both T1 and T2 respectively. The highest mean manual operation and lowest back flushing operation was recorded in disk filters due to low concentration of BOD₅ (mg/l) and TSS (mg/l) in T1 compared with T2. While in T2 decreased by increasing sequence BOD₅ (mg/l) and TSS (mg/l). There were direct relation between the content of wastewater and some operational defects considering the great emitter clogging problems that means the clogging particles were not blocked by the filter.

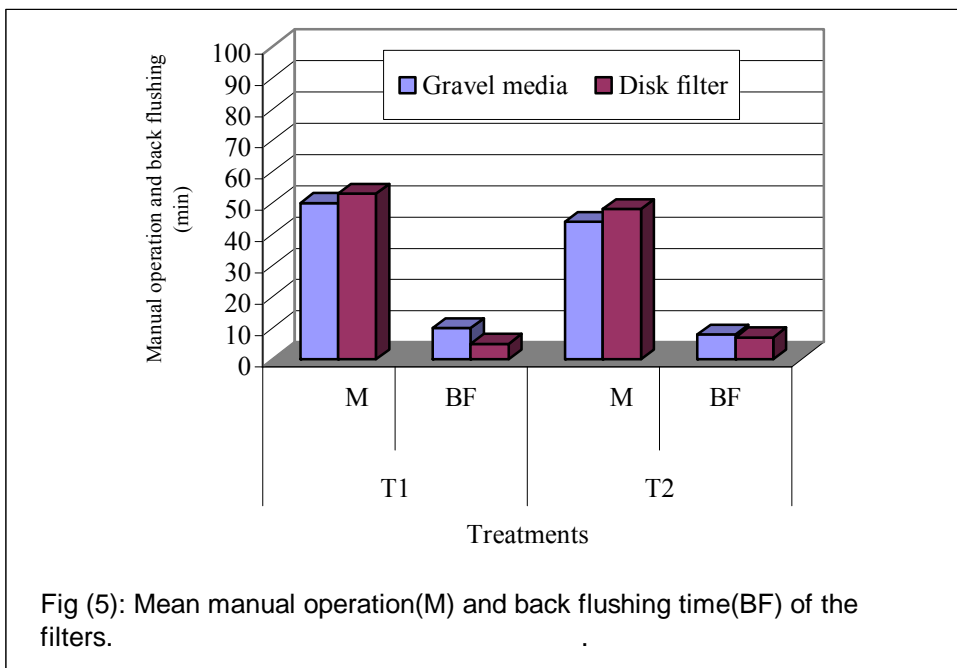

5- Influence of wastewater characteristics on emitter and filter performance

The influence of wastewater characteristics on emitter and filter performance indicated the previous discussion of the results. The previous results show a good correlation between the total suspended solids and the performance indices measured, whereas the organic matter content, expressed by BOD₅, is the worst correlated. The treatment (1) with low BOD₅ (mg/l), TSS (mg/l), Calcium (mg/l), and Magnesium (mg/l), so that the emitters performance of on line labyrinth was generally better than the on line emitters especially in large diameters pipes. The inline emitters with a similar discharge were more sensitive to clogging than online emitters. Generally the emitters in and on pipes with a smaller diameter were more sensitive to clogging compared with the same types of emitter in pipes with a greater diameter.

The results showed there was great influence of the treated wastewater quality on the performance of drip irrigation systems: for the same type of emitter and filter. When the total suspended solids and organic matter content increased, the percentage of totally clogged emitters also increased, whereas the mean emitted discharge, the emission uniformity coefficient, and the operating time of the filters between cleaning operations decreased in the test.

The theoretical discharge of filters, suggested by the manufacturers for clean water, is not adequate for wastewater of the types used were very short. The test shows that the existing clogging risk classifications proposed for clean water can only be considered reliable for wastewater when labyrinth emitters and gravel or good quality disk filters are used.

CONCLUSION

The experiment studied influence of the water quality on the performance of drip irrigation systems for the different types of emitter and filter. When the total suspended solids and organic matter content increased, the percentage of total clogged emitters also increased, whereas the mean

discharge of emitters, the emission uniformity coefficient, and the operating time of the filters between cleaning operations decreased the emitters with a similar discharge, online emitters were more sensitive to clogging than inline emitters. Gravel media filter decreased the emitter clogging and increasing performance. The disk filter, of good quality, is cheaper and simpler to manage, and assured performance levels similar to those of the gravel media filter. Automatic back flushing systems are also preferable to avoid contact between the wastewater and the irrigator with short operating times of the filters between manual cleaning operations. The water characteristics, total suspended solids and organic matter content are sufficient to classify clogging risk with treated wastewater not submitted to advanced treatment. The variability of the water quality of the same treatment system caused certain variability in the performance of the irrigation systems. Increasing the total suspended solids and BOD₅ and chemical analysis in T2 more than T1 led to decreasing EU percentage.

The theoretical discharge of filters, suggested by the manufacturers for clean water, is not adequate for wastewater of the types used were very short. The test shows that the existing clogging risk classifications proposed for clean water can only be considered reliable for wastewater when labyrinth emitters and gravel or good quality disk filters are used.

REFERANCES

- Al-Jamal, M.S., Sammis, T.W., Mexal, J.G., Picchioni, G.A. and Zachritz, W.H., (2002).** A growth-irrigation scheduling model for wastewater use in forest production. *Agric. Water Manage.* 56, p: 57–79.
- ASAE Standards, (1996).** Amer. Soc. Agric. Eng., St. Joseph, MI.:792-797.
- Bahri, A., (1999).** Agricultural reuse of wastewater and global water management. *Water Sci. Technol.* 40 4–5, p: 339–346.
- Barbagallo, S., Capra, A., Piccione, G., Scicolone, B., (2002).** Drip irrigation using municipal wastewater. Emitter and filter tests. In: Proc. of the Quinta Conf. Cientifica Int. UNICA, Ciego de Avila, Cuba, p:102–116

- Boswell, M. J. (1985).** Design characteristics of line source drip tubes. Proc. of the 3rd Int. Drip/Trickle Irr. Cong. , Vol.1 Ca., USA. p: 306-312.
- Braud, H.J and A.M. Soon (1980).** Trickle irrigation design for improved application uniformity. ASAE and CSAE Mtg. on trickle (drip) irri., paper no. 79-2571 , Winnipeg, Canada.
- Camp,C.R., E.J. Sadlerand W.J.Busscher, (1997).** A comparison of uniformity measure for drip irrigation systems. Trans Am. Soc. of Ag.Eng.40 (4), 1013-1020.
- Capra, A. and Scicolone, B., (1998).** Water quality and distribution uniformity in rip/trickle irrigation systems. J. Agric. Eng. Res. 70, pp. 355–365
- Capra, A. and Scicolone, B., (2004).** Emitter and filter tests for wastewater reuse by drip irrigation. Agricultural Water Management Vol. 68, Issue 2 p: 135-149.
- El-Berry A.M., M.T. El- Tantawy, A. I. Ghazy, and E. Wasef (2003)** Use of foam Media for filtering heavy sediments water. Egypt .J. of Ag. Res.;81 (4) p:1931-1945
- Friedler, E., (2001).** Water reuse—an integral part of water resources management: Israel as a case study. Water Policy 3, p:29–39.
- Keller, J., Bliesner, R.D., (1990).** Sprinkle and Trickle Irrigation. AVI Book, New York, USA, p: 652.
- Nakayama, F.S. and Bucks, D.A., (1991).** Water quality in drip/trickle irrigation: a review. Irrig. Sci. 12 4, pp. 187–192.
- Ravina' I. , E. Paz., Z. Sofer, A. Marcu, A. Shisha and G. Sagi (1992).** Control of Emitter clogging in drip irrigation with reclaimed wastewater. Irrigation Science . Vol. 13, No 3 p: 12-21

الملخص العربي

أداء المرشحات والنقاطات تحت تأثير مياه الصرف الصحي المعالج

* د/ مجدي توفيق الطنطاوي * د/ مجدي عبد الوكيل مطر ** د/ ياسر عزت عرفه

تم إجراء تجربة في محطة الصرف الصحي المعالج بسرابيوم - محافظة الإسماعيلية في تربة رملية لدراسة تأثير استخدام اثني عشر معاملة معاملتان لمياه الصرف المعالج بتركيزات شوائب عضوية وغير عضوية مختلفة نوعان من النقاطات وثلاث أزمنة تشغيل صفر، 50، 100 ساعة تشغيل علي كفاءة أنواع مختلفة من المرشحات (رملية - قرصية) وأنواع مختلفة من النقاطات داخلية وخارجية لري الأشجار الخشبية تحت نظام الري بالتنقيط. تم تصميم التجربة بنظام القطاعات المنشقة مرتين مستخدما برنامج التحليل الإحصائي MSTATc. ويعتبر نظام الري بالتنقيط مناسب لاستخدام مياه الصرف الصحي المعالج نتيجة عدم التلامس المباشر معها وكان المشكلة التي تواجه الفلاحين هي انسداد النقاطات والمرشحات نتيجة زيادة المواد العضوية مثل BOD₅ و TSS والمواد الغير العضوية مثل الكالسيوم والماغنسيوم خلال زمن تشغيل كلي 100 ساعة وتأثير ذلك علي الانسداد الجزئي والكلي للنقاطات وكذلك الانسداد الجزئي للمرشحات متوسط النسبة المئوية للفق في تصرفات المرشحات وانتظامية توزيع النقاطات وكذلك متوسط زمن تشغيل المرشحات وزمن الغسيل العكسي للمرشحات الرملية و تحت تركيزات مختلفة من مياه الصرف الصحي المعالج. وكانت أهم النتائج المتحصل عليها هي:

النقاطات الخارجية أفضل من الداخلية للأسباب التالية:

- أقل حساسية للانسداد الجزئي والكلي نتيجة تراكم المواد العضوية والغير عضوية وأقل في النسبة المئوية للفق في للتصرف وأعلي في انتظامية توزيع النقاطات مقارنة بمعاملة المياه الثانية تحت أزمنة التشغيل المختلفة حتى 100 ساعة تشغيل نتيجة انخفاض تركيزات المواد العضوية BOD₅ و TSS والغير العضوية بها مثل الكالسيوم والماغنسيوم.
- يفضل استخدام المرشح الرملي يتبعه المرشح الشبكي في المعاملة الأولى عن المعاملة الثانية لانخفاض التركيزات العضوية والغير العضوية أدي إلي انخفاض الانسداد الجزئي في المرشحات الرملية والشبكية بنسب مئوية 14.6% ، 11.3% وكذلك انخفاض النسبة المئوية للفق في التصرف بنسب مئوية 4.3% ، 3.2% علي الترتيب وزيادة زمن تشغيل وزمن الغسيل العكسي في المعاملة الأولى للمرشحات الرملية والشبكية مقارنة بالمعاملة الثانية نتيجة انخفاض المواد العضوية والغير العضوية.
- زيادة انتظامية التوزيع للنقاطات الخارجية بصفة عامة بصورة مقبولة في كلا المعاملتان الأولى والثانية مقارنة بالنقاطات الداخلية حتى زمن تشغيل كلي 75، 25 ساعة علي الترتيب وكذلك زيادة انتظامية التوزيع للنقاطات الخارجية في المعاملة الأولى مقارنة بالمعاملة الثانية علي الترتيب.

*معهد بحوث الهندسة الزراعية - مركز البحوث الزراعية - وزارة الزراعة واستصلاح الأراضي
**قسم الهندسة الزراعية- كلية الزراعة- جامعة عين شمس.