

# A STUDY ON AGRICULTURAL TRACTORS STEERING MECHANISM 1-THE STEERING ANGLES

\*Sarhan, A. M. M.      \*\*Al – Katary, H. S.      \*\*\*El- Awady, M. N.

## ABSTRACT

*The main aim of this research was to increase the operation efficiency of agricultural tractor to suit the conditions and potentials of the Egyptian farmer. This leads to increase the rates of the feddan production and raise the value of the yield per feddan. This meets the requirement to achieve the strategic goals of the agricultural development by modifying and developing the modern technology, especially the agricultural tractors to suit the local environment in all agricultural operations, including plowing. Laboratory experiments and statistical analysis for the data of the research were run and hydraulically steering was designed by using a closed hydraulic circuit for the tractor. The main results obtained from the experiments are summarized in the following main points:*

- 1. Mathematical equations are derived to find the steering angles.*
- 2. Decreasing the repeated technical problems in the steering equipments of the tractors.*
- 3. Decreasing the operation, maintain and used spare parts in the steering equipments of tractors. 4-The modification suits all the agricultural operations even for small holdings in Egypt.*

## INTRODUCTION

**T**he agricultural tractor is the backbone of the Egyptian agriculture because it does all the different field processes. It must be improved to suit the conditions and potentials of the Egyptian farmer to increase the efficiency of its operation. This study aims to develop steering in particular. It aims to design a mechanism which can be controlled hydraulically to work on the front land-wheels. **Louis and Kersey (1938)** mentioned that correct steering of wheels should be in planes which are tangential to their respective paths.

---

\*Ph. D. Stud. Dept. Eng., Fac. Agric., Al-Azhar Univ. Cairo Egypt .

\*\*Prof., Agric. Eng. Dept., Fac. Agric., Al-Azhar Univ. Cairo Egypt .

\*\*\*Emt. Prof., Agric. Eng. Dept., Fac. Agric., Ain Shams Univ.

This disposition of the wheels is obtained if, and only if, the axes of the two front wheels intersect at a point on the common axis of the back wheels. The point of intersection is then the instantaneous centre of rotation of the chassis and the wheel rolls without sidewise slipping. In Fig. (1),  $W_1$ , and  $W_2$  are the front wheels in the position for steering a straight course. The axles of  $W_1$  and  $W_2$  are pivoted at the points A and B, respectively, these points of  $W_1$  and  $W_2$  are pivoted at the points A and B respectively, these points being fixed to the car of steering gear, the wheels are moved relative to the chassis into the positions shown in full at  $W'_1$  and  $W'_2$  the car will move in circular course. The steering will be correct if, and only if, K, the point of intersection of the axes of  $W'_1$  and  $W'_2$  lies on the axis of the back wheels.

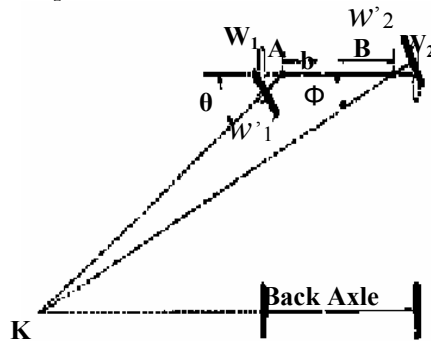

Fig. (1): Position of axles for correct steering,

**Louis and Kersey (1938).**

Let  $AB=b, H$ =distance between AB and the back axis, and let  $\theta$  and  $\phi$  be the acute angles between AK and BK, respectively and the line AB or AB produced. We have by a well-known trigonometric formula:

$$\cot \phi - \cot \theta = \frac{b}{H}$$

*Liljedahl and Strait (1962b)* indicated that Caster is produced when the vertical axis of rotation of the wheel is a distance ahead of the center of contact between the ground and the wheel, are shown in Fig.(2).

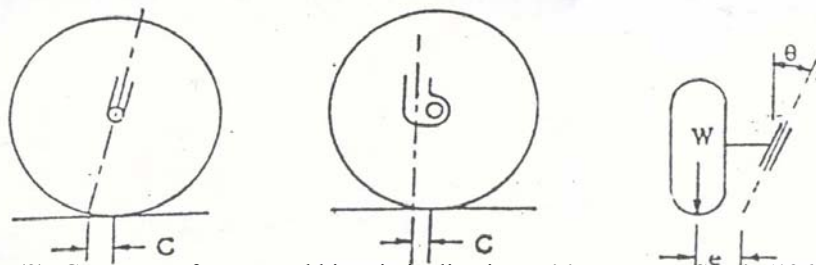

Fig.(2): Geometry of caster and kingpin inclination, **Liljedahl and Strait (1962b)**.

**Whitaker (1976)**: stated that caster, Fig. 3(a), helps to prevent wander. Camber, Fig.5 (b), gives greater stability on uneven surfaces. Tractors ordinarily are designed with a considerable amount of camber as they are frequently required to operate on uneven ground. Toe-in, Fig.3(c), largely counteracts the tendency of cambered wheels to turn outward as though they were large cones turning around their apexes. Kingpin inclination Fig. 3(b). helps to reduce road shocks such as those caused by holes, stones and high spots. As kingpin inclination tends to lift the front of a vehicle during a turn, the weight tends to bring the vehicle out of a turn into a straight path. **He also** indicated that the toe-out, Fig.(4). characteristic causes the radii of all four wheels to meet at an approximate common center during a turn. For any turn angle of the outer wheel, the correct angle for the inner wheel the correct angle for the inner wheel may be found graphically as shown in Fig. (4). or by the following equation:

$$\text{Cot } B = \text{Cot } A - \frac{TW}{WB}$$

**Where:**

**A**= the outer turn angle. **B**= the inner turn angle. **TW**= the tread-width.

**WB**= the wheelbase.

This equation may be used repeatedly to obtain as many pairs of turn angles (**A** and **B**) as are desired.

**Smith et al. (1985)** computed the “actual” position and orientation of the machine. The “correct” position and orientation, and steering angle of the machine were then computed relative to the desired path, and position error was used to compute a proportional adjustment for the steering angle.

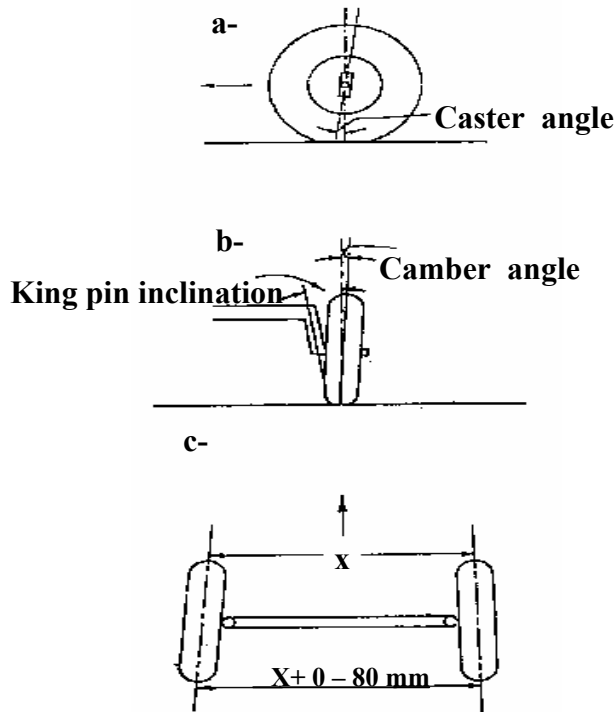

Fig. (3): [a]-Front wheel caster; [b]- Camber and king pin inclination; [c]-Front wheel toe-in, **Whitaker (1976)**.

They concluded that the “constant-turn” geometry techniques are useable for machine guidance; however, the resulting algorithms must be tested under real-world dynamic conditions to verify their adequacy.

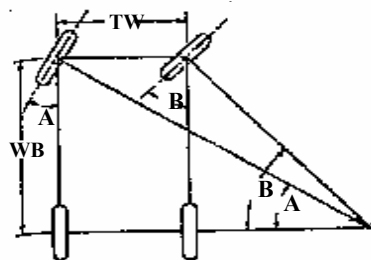

Fig. (4): Front wheel toe-out during a turn, **Whitaker (1976)**.

Using a computer program based on mathematical analysis for the coplanar linkage, deviations from the ideal Ackermann geometry were plotted, as shown in Fig.(5). (**Zhang, 1985**). This relationship is expressed by the following equation:

$$\text{Cot} \beta - \text{Cot} \alpha = M / L$$

Where:  $\beta$ =outside steering angle.  $\alpha$ =inside steering angle.  
 $M$ =distance between the two points of kingpin's extension on the ground  
 $L$ =wheelbase.

*Smith et al. (1987)* concluded that the analysis of steering geometry and machine motion using the concepts embodied in constant-turn geometry was adequate for defining the system of geometric relationships (algorithm) needed to guide agricultural machines.

They found that the performance of the guidance algorithms were influenced by the distance traveled between steering angle computations, and the magnitude of the steering angle gain factor.

*Zhang et al. (1988a)* found that mathematical relationships between inside an outside steering angle developed for coplanar and independent steering linkages can be used to optimize the design of steering linkage system.

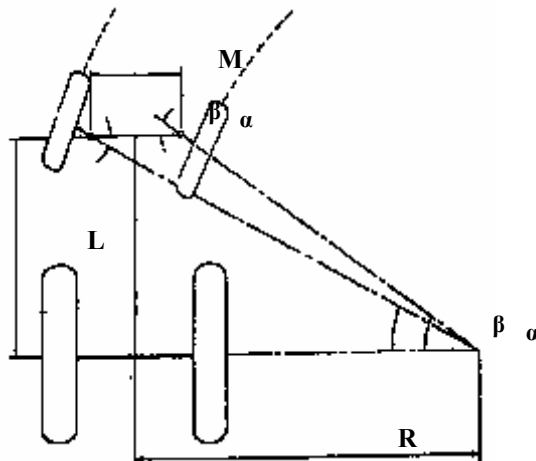

Fig. (5): Schematic of Ideal Ackermann geometry,(Zhang, 1985).

*Zhang et al. (1988b)* said that using steering systems can not comply with ideal Ackermann geometry even with those optimum designed ones. A new type of steering system to improve steering performance is needed.

Steering mechanism, called the **CCS** steering system, has been developed, which is able to satisfy the Ackermann geometry at any angle within the steering range. The features of the **CCS** steering box make are suitable for trucks and vans.

## **MATERIAL AND METHODS**

### **A- Tractor:**

The Belarus tractor, **65B.HP (48.2Kw)** was common and widespread under Egyptian local conditions. The tractor is all purpose of the model **10M3-6KM**. It was used in this research. The tractor was tested in plowing operation. After modification it was tested at agricultural tractors and machinery research laboratory, Agricultural Engineering Department, Faculty of Agriculture, Al-Azhar University.

### **A-1: The tractor before modification:**

1-Gasoline engine (65 Hp, 48.2Kw) at 1750 rpm. 2- Wheels (four wheels). 3-Minimum turning radius = 5m.

### **4- Steering system:**

#### **(A): The components:**

It consists of: **(1):**Front axle; **(2):**Steering wheel to track width adjustment mechanism, determining the front wheel toe-in and checking toe-in of steering wheels; **(3):**Sector, spool, bushing, steering gear case, rack and oil drain pipeline (Fig.6); **(4):** Steering column, shock absorbers, sleeve, steering wheel shaft and steering wheel; **(5):** Steering gear, steering arm, steering shaft and worm gear; **(6):**Hydraulic steering servo, housing, spring washer and front cover; **(7):**Mounted at the middle position on the tractor.

#### **(B): The disadvantages of power steering:**

1- Difficult to repair and maintain. 2-Costs of repair and maintenance. 3- The spare parts price is expensive. 4-Complex construction. 5-Mechanical steering system with addition to hydraulic steering servo.

### **A-2: The tractor after modification:**

The tractor was modified to overcome the problems encountered during the experimentation. The specifications of the tractor after modification are the same of tractor before modification but the different are follows:

### **Apparatus of power hydraulic steering system:**

It was power hydraulic steering circuit, Fig (7):

**The components:** It consists of: 1- Reservoir (Transmission housing); 2- Filter on intake; 2B-Filter on delivery; 3- Hydraulic pump. It consists of: A-Suction port; R-Lube fillets;

1): Bearings; 2):Seals; 3):Cover; 4):Key; 8):Bearing; 9):Bushes; 10):Pipe union; 11):Pump body; 12):Engine block; 13):Conductor pinion; 4-Rotary valve; 5, 9- Check valve; 6-Pressure relief valve; 7- Hydraulic steering control valve: It consists of: 1): Fixing screw; 2): Lower cap; 4):Spacer; 6):Stator; 7): Rotor; 8):Intermediate flange; 9):Non return valve; 10): Pressure limit valve; 14): Distributor; 15, 18):Anti-cavitations valve; 6):Distributor body; 17):Anti-shock valve; 19):Short circuit valve; 21):Grooved hub; 25):Upper cap. 8- Transfer pump/motor; 17-Sleeve; 18-Anti-shock valves (cylinder safety valves); 19-Anti-cavitations valves (Makeup valves); 22- Power cylinder (Fig. 16 and photo.4):It consists of: 1):Cylinder; 2):Locking; 3): Bearing; 4):Gland; 5):“O” Ring; 6, 12, 13):Seal; 7): Wiper seal; 8):Gland locking; 9):Cylinder rod; 10):Retaining Ring; 11):Piston.

23- Ducts: A-Intake; B- Delivery; C-Return; D-Users on LH side of power cylinder; E-Users on RH side of power cylinder; F-Anti-shock valve discharge; G- Transmission oil cooler; R-Flow regulator; W-Steering wheel.

**B-: Devices:**

**B-1: Surveying instruments:** Tape steel, arrows and steel ruler were used for measuring and determining longitudinal dimensions. Pins were used for hitching the dynamometer from both sides. Steel bolts and plastic threads were used for determining angle.

**B-2: The models:** Models were made at the central workshops in the Ministry of Agriculture and Land Reclamation, to measure the steering angles. Models for the mechanisms were made of wooden bars, for the various geometrical dimensions. They generally conform to as small scale of 1:2The model configurations had the variable dimensions shown in table1.

**Table (1):** The variable dimensions of the models.

Configuration No.	Dimensions in mm.					
	W	W/2 or W/3	TR	r	Cotφ - Cot θ	
1	960	W/2	480	912	192	0.39
2	1110		555	1050	222	0.45
3	1260		630	1200	252	0.51
4	1410		705	1340	282	0.58
5	1110	W/3 =370	1050	222	0.45	

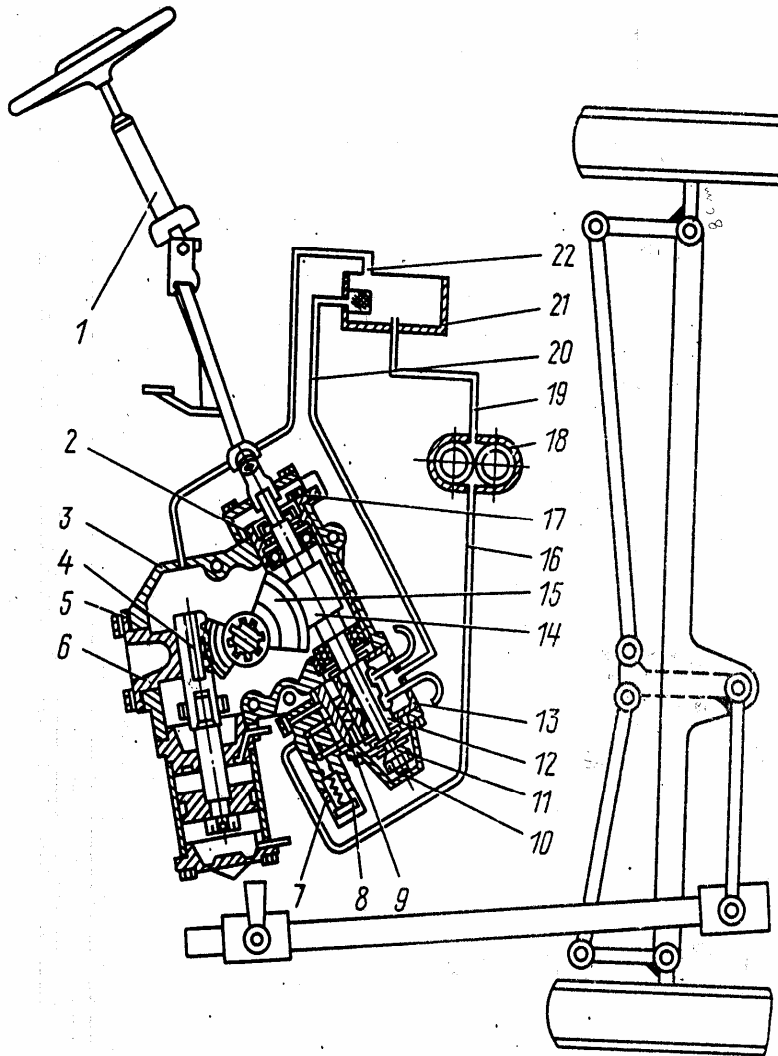

**Fig. (6): Diagram of steering gear hydraulic Booster:**

1- steering column ; 2- bushing ; 3- steering gear case ; 4- rack ; 5- gasket ; 6- rest 7- lock nut ; 8- screw ; 9- safety valve ; 10- cover ; 11- spherical nut ; 12 – spool ; 13- control valve housing ; 14- worm ; 15- sector ; 16- oil delivery pipeline ; 17- bolt ; 18- oil pum ; 19 – oil suction pipeline ; 20- oil return pipeline ; 21 – oil tank ; 22- oil drain pipeline (**Gurevich and Sorokin,1976**).





Their dimensions consist of fixed dimensions ( $\text{Cot}\theta = W/WB$ ,  $WB = 2450$ ,  $e = 70\text{mm}$ ,  $r/W = 0.2$ ,  $TR/W = 0.95$  and  $\gamma_0 = \pi/2 = 90^\circ$ ). The rest of dimensions are shown in (Fig.9).

A natural-size model was made of steel to Conform with the tractor modifications.

**Where:**  $WB$ =Wheel base,  $W$ =Steering pivots distance (1110mm),  $r$ =Steering arm length,  $TR$ =Tie-rod length,  $\phi$ = Outer front wheel steering angle,  $\theta$  = Inner front wheel steering angle,  $e$ =the distance between tie-rod and hydraulic cylinder base  $\gamma_0$ = Upright angle, equal ( $\pi/2$ ).

### C- Experimental procedures:

Steering angles was tested by measuring the average turning cycle of tractor under test. The steering angle of each cycle of the tractor was recorded to determine the steering angles by steel bolts, plastic threads, steel ruler and tape in fifteen replicates. The aim of this test was to determine the steering angle for piston, inner, and outer front wheels of the tractor under test at average speed at no traction loads over concrete traction surface (Fig. 8).

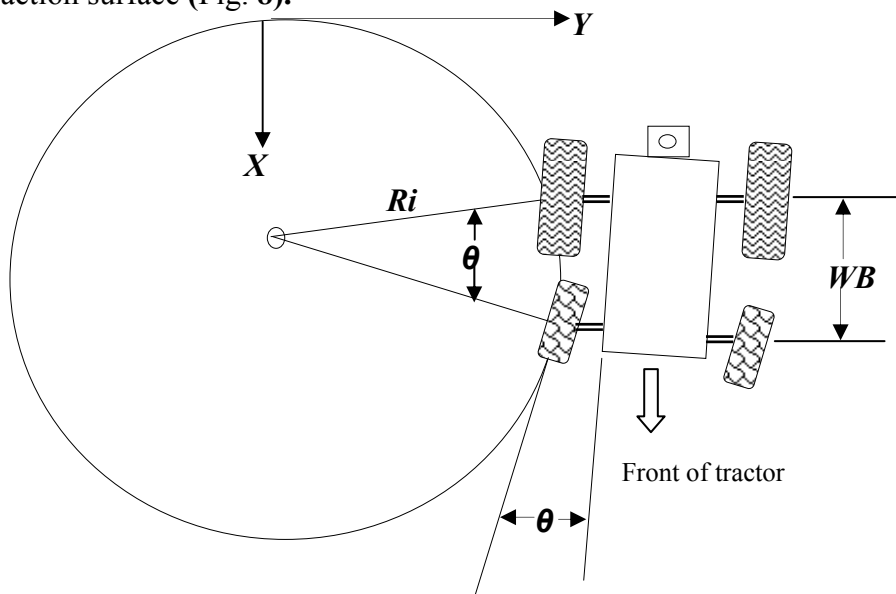

Fig. (8): Motion resulting from a constant steering wheel displacement

**D-Using mathematical analysis for the common-center-steering systems of tractors:**

Analytical program was derived for 4-bar mechanism (steering mechanism referring to Figs. (8 through 10) based on the mechanism data:

WB:wheel base(2450mm), W:Steering pivots distance(1110 mm), r:Steering arm length(222mm),  $\theta_0$ :Initial steering arm angle(8.29°), TR:Tie-rod length(105cm),  $\theta$ :Inner front wheel steering angle,  $\phi$ :Outer front wheel steering angle; I: Instantaneous center. Equations of the wheels steering angles are given as shown in Figs (8 through 10)

**RESULTS AND DISCUSSION**

The study was carried out to indicate effects of the cylinder length and the tractor dimensions at different geometric proportions on the following factors:

**1-Effect of the front wheels steering angles on steering angles:**

The inner and outer steering angles refer to those made by the radii of the wheels to the inside or outside of the turning curves reap, as shown in figures (8 through 12) illustrate the effect of front wheels steering angles and dimensions of the tractor on the steering angles at different geometric proportions. The steering angle equations can be derived, as follows:

$$\phi_{th} = \tan^{-1} \left( \frac{1}{\frac{W}{WB} + \frac{1}{\tan \theta}} \right); \phi_{act} = \tan^{-1} \left( \frac{W - x_0}{y_0 - 0} \right); \theta_{th} = \tan^{-1} \left( \frac{1}{\frac{1}{\tan \phi} - \frac{W}{WB}} \right)$$

Where:  $\phi_{th}$ : Perfect or the theoretical outer front wheels steering angles;  $\theta_{th}$ : Perfect Inner front wheels steering angle; **W**:Steering pivots distance(111cm); **WB**:Longitudinal wheel base(245cm);  $\phi_{act}$ : Actual outer steering angle equal( $\phi - \theta_0$ );  $\theta_{act}$ : Actual inner steering angle( $\theta_{act} = \theta + \theta_0$ );  $\theta_0$ :Initial steering arm angle(8.29°);  $\theta$ :Inner steering angle;  $\chi_0$ : The tie-rod length opposite of outer steering angle(arc sine  $\phi$ );  $y_0$ : Steering arm length adjacent of outer steering angle(arc cosine $\phi$ ).

From figures (11 and 12) it is clear that the theoretical outer front wheels steering angle ( $\phi_{th}$ ) increased with the inner steering angle ( $\theta$ ) at different values of **W/WB**. Meanwhile, values of ( $\phi_{th}$ ) decreased with

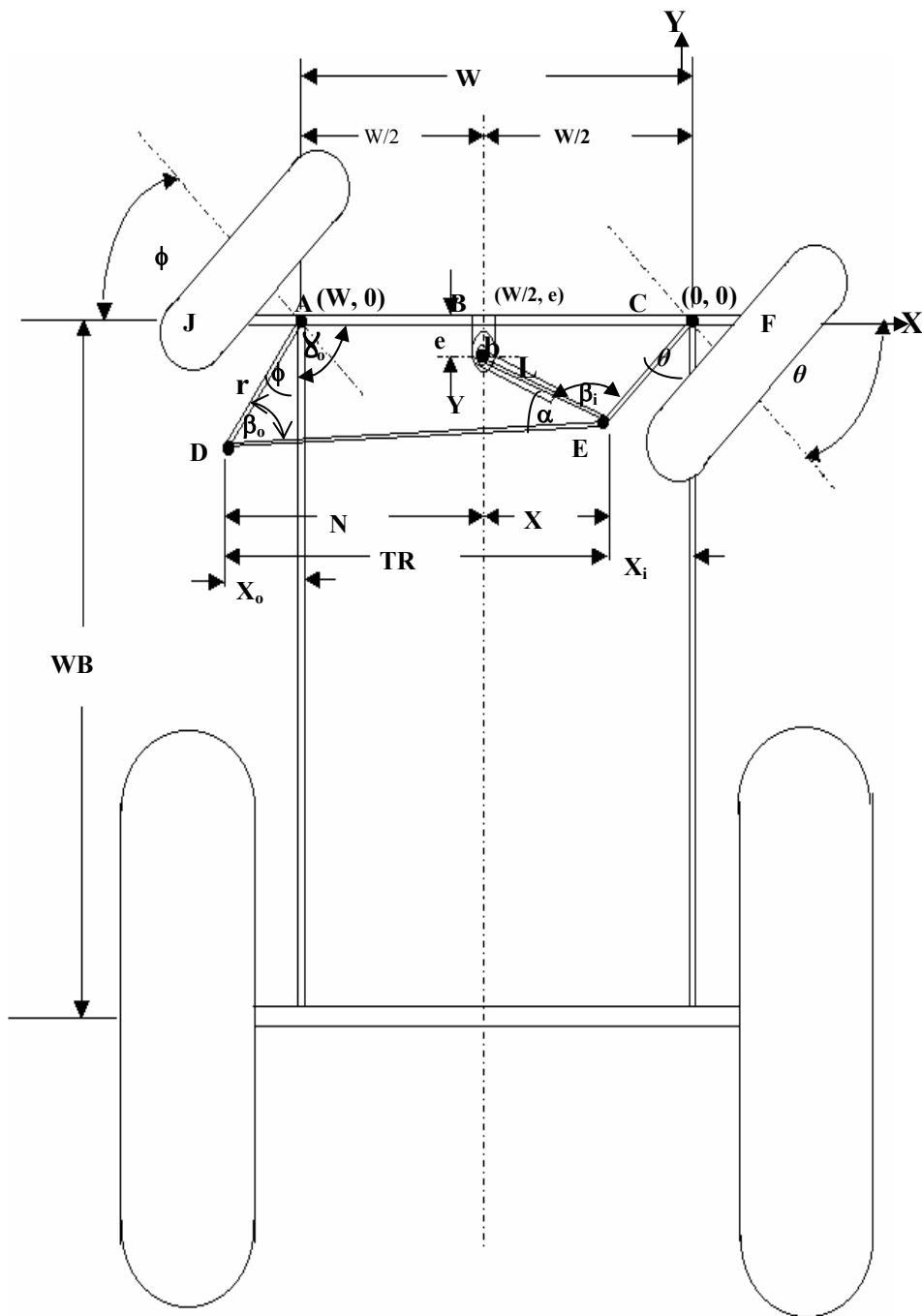

Fig. (9): Steering geometry during a turn of the tractor to the right direction and dimensions of the mechanism ( $\theta$ : inner;  $\phi$ : outer steering angles).

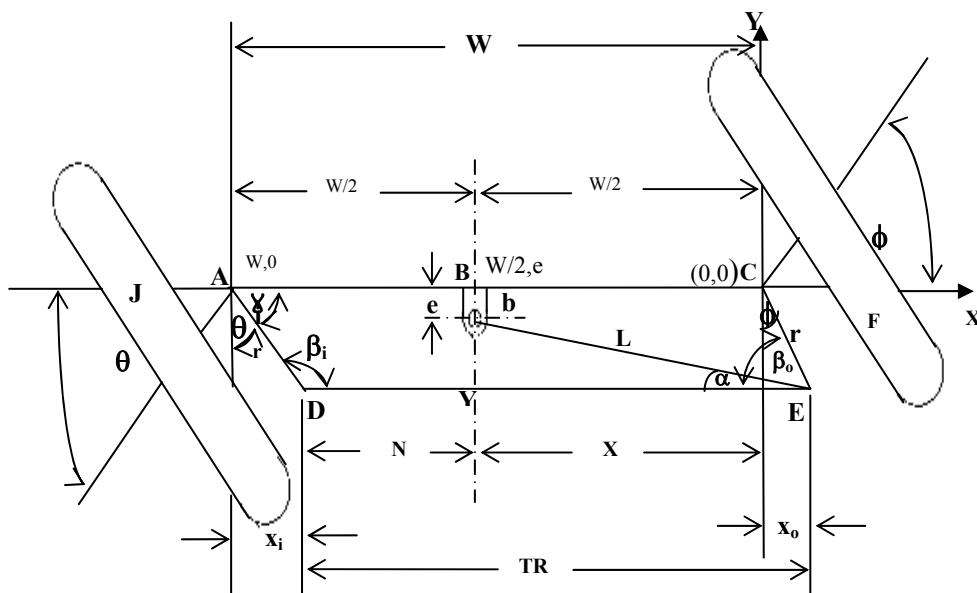

Fig. (10): Tie rod length ( $TR$ ) when wheels are turned to the left direction and steering arm angle ( $\alpha$ ).

Increasing values of  $W/WB$ . Values of  $(\phi_{th})$  varied from about [(43.90 to 36.75) degrees] at values of  $W/WB$  varying from about 0.20 to 0.50 respectively for value of  $(\theta)$  of about 50 degrees.

From Fig. (12). it is clear that the actual and theoretical outer steering angles ( $\phi_{act}$ ;  $\phi_{th}$ ) increased with the inner front wheels steering angles ( $\theta$ ). Values of  $(\phi_{act})$  varied from about 1.95 to 90.79 degrees higher than values of  $(\phi_{th})$  varied from about 1.97 to 37.74 degrees at values of  $(\theta)$  varying from about 2 to 50 degrees respectively for value of  $W/WB$  of about 0.45.

## **2- Effect of the hydraulic cylinder length on steering angles:**

Figures (8 to 10 and 13) illustrate effect of the hydraulic cylinder length, the piston steering angle ( $\alpha$ ), for constant dimensions of the tractor on the inner and outer front wheels steering angles ( $\phi_{th}$ ,  $\theta_{th}$ ) at different geometric proportions. The theoretical steering angles equations can be derived as follows:

**A-** The right direction (**R.H.Steer**):      **B-**The left direction (**L.H.Steer**):

$$\begin{aligned} \therefore \phi_{th} &= \sin^{-1} \left( \frac{TR - \frac{W}{2} - L \cos \alpha}{r} \right) & \therefore \theta_{th} &= \sin^{-1} \left( \frac{\frac{W}{2} - TR + L \cos \alpha}{r} \right) \\ \therefore \phi_{th} &= \sin^{-1} \left[ \frac{TR - \frac{W(wb)}{WB} - L \cos \alpha}{r} \right] & \therefore \theta_{th} &= \sin^{-1} \left[ \frac{\frac{W(wb)}{WB} - TR + L \cos \alpha}{r} \right] \\ \therefore \phi_{th} &= \sin^{-1} \left[ \frac{TR - \frac{W}{2} - \sqrt{L^2 - Y^2}}{r} \right] & \therefore \theta_{th} &= \sin^{-1} \left[ \frac{\frac{W}{2} - TR + \sqrt{L^2 - Y^2}}{r} \right] \\ \therefore \phi_{th} &= \sin^{-1} \left[ \frac{TR - \frac{W(wb)}{WB} - \sqrt{L^2 - Y^2}}{r} \right] & \therefore \theta_{th} &= \sin^{-1} \left[ \frac{\frac{W(wb)}{WB} - TR + \sqrt{L^2 - Y^2}}{r} \right] \end{aligned}$$

**Where:** L: The hydraulic cylinder length, cm; r: Steering arm length (22.2cm); TR: Tie-rod length(105cm);  $\alpha$ :Piston steering angle; Y: The tie-rod length adjacent of piston steering angle (arc sine  $\alpha$ ).

From Fig. (13). it is clear that the perfect inner and outer front wheels steering angles ( $\theta_{th}$ ,  $\phi_{th}$ ) increased with the hydraulic cylinder length. Values of ( $\theta_{th}$ ) varied from about 21.68 to 68.82 degrees, higher than the values of ( $\phi_{th}$ ) varied from about 18.82 to 49.95 degrees at the hydraulic cylinder length varying from about 58.9 to 70.4 cm respectively for value of W/WB of about 0.45. Also, Fig. (13). indicates that the perfect inner and outer front wheels steering angles ( $\theta_{th}$ ,  $\phi_{th}$ ) decreased with increasing values of W/WB. Values of ( $\theta_{th}$ ;  $\phi_{th}$ ) varied from about [(44.32 to 32.13) ;( 35.09 to 24.48) degrees] at values of W/WB varying from about 0.39 to 0.58, respectively. Also, Fig. (13), shows that the maximum values of the perfect inner and outer front wheels steering angle ( $\theta_{th}$ ;  $\phi_{th}$ ) were (74.48; 56.20 degrees) at value of W/WB of about 0.39 for the hydraulic cylinder length 61.9 cm. Meanwhile, the minimum values of ( $\theta_{th}$ ;  $\phi_{th}$ ) were (17.54; 14.97 degrees) at value of W/WB of about 0.58, for the hydraulic cylinder length 73.2 cm, respectively.

### SUMMARY AND CONCLUSION

The present study was carried out by using two tractors mounted type chisel plough of 7 tines in two rows locally industrial were used, the

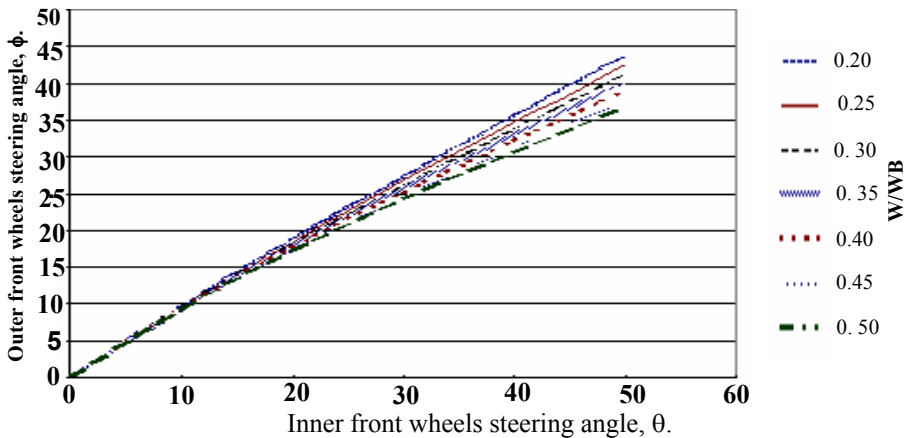

Fig.(11):The relationship between the inner and outer front wheels steering angles for 4-bar steering mechanism at the different values of W/WB

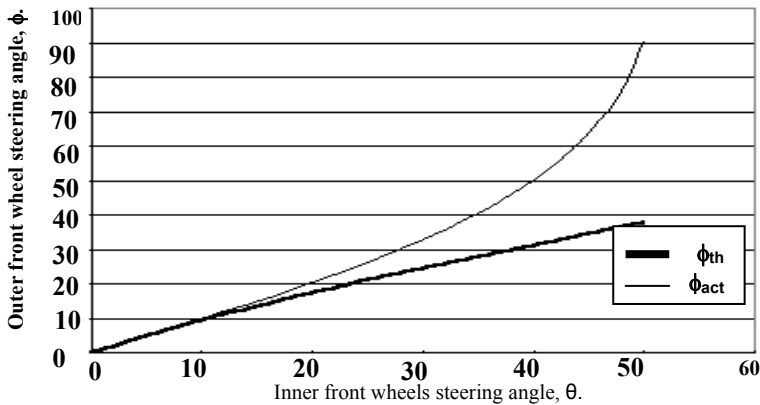

Fig (12): Effect of the inner front wheels steering angle on the theoretical and actual outer front wheels steering angles for 4-bar steering mechanism at value W/WB 0.45.

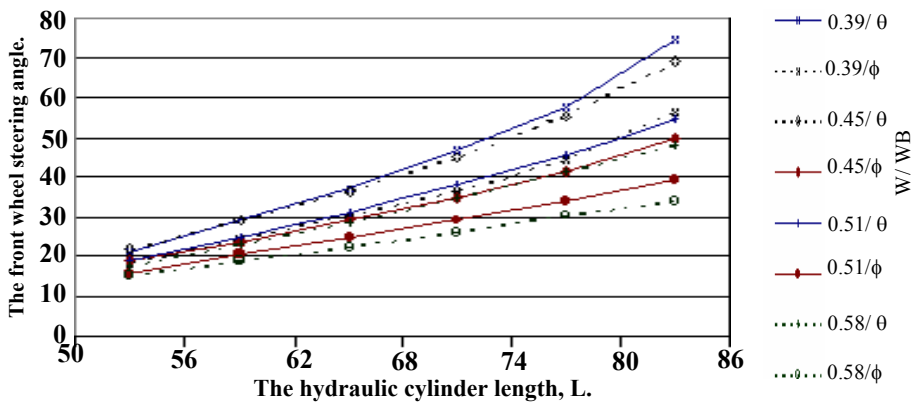

Fig.(13): Effect of the hydraulic cylinder length, the hydraulic cylinder length ratio to the width of the pivot points at level of the steering arms (L/W) on the steering angles for 4-bar steering mechanism at the different values of W/WB.

Belarus tractor, **65B.HP** was usage common and widespread under Egyptian conditions. The tractor before, after common and widespread under Egyptian conditions. The tractor before, after modification (this modification allowed tested tractor to decrease the turning radius from **5** to **1.5** m and decrease the friction between the front wheels and the steering equipments) were constructed and tested at agricultural tractors and machinery research laboratory, Agricultural Engineering Department, Faculty of Agriculture, Al-Azhar University. The main results obtained from experiments are summarized under the following main points:

**(a): Effect of the front wheels steering angles on the steering angles:**

The theoretical outer steering angle( $\phi_{th}$ ) increased with inner steering angle( $\theta$ ). Meanwhile, values of ( $\phi_{th}$ ) decreased with increasing values of W/WB. Values of ( $\phi_{th}$ ) varied from about [(43.90 to 36.75) degrees] at values of W/WB varying from about 0.20 to 0.50 respectively.

The actual and theoretical outer front wheels steering angles( $\phi_{act}$ ,  $\phi_{th}$ ) increased with the inner steering angles( $\theta$ ). Values of ( $\phi_{act}$ ) varied from about 1.95 to 90.79 degrees higher than values of ( $\phi_{th}$ ) varied from about 1.97 to 37.74 degrees at values of ( $\theta$ ) varying from about 2 to 50 degrees respectively.

**(b): Effect of the hydraulic cylinder length on steering angles:**

The perfect inner and outer front wheels steering angles( $\theta_{th}$ ,  $\phi_{th}$ ) increased with the hydraulic cylinder length. Values of ( $\theta_{th}$ ) varied from about 21.68 to 68.82 degrees, higher than values of ( $\phi_{th}$ ) varied from about 18.82 to 49.95 degrees at the cylinder length varying from about (58.9 to 70.4 cm), respectively.

The perfect inner and outer steering angles ( $\theta_{th}$ ,  $\phi_{th}$ ) decreased with increasing values of W/WB. Values of ( $\theta_{th}$ ;  $\phi_{th}$ ) varied from about [(44.32 to 32.13); (35.09 to 24.48) degrees] at values of W/WB varying from about 0.39 to 0.58, respectively.

The maximum values of the perfect inner and outer front wheels steering angle ( $\theta_{th}$ ;  $\phi_{th}$ ) were (74.48; 56.20 degrees) at value of W/WB of about 0.39 for the hydraulic cylinder length 61.9 cm. Meanwhile, the minimum values of ( $\theta_{th}$ ;  $\phi_{th}$ ) were (17.54; 14.97 degrees) at value of W/WB of



about 0.58, for the hydraulic cylinder length 73.2 cm, respectively, increased efficiency of the tractor.

### **REFERENCES**

**Liljedal, L.A.; J. Strait (1962b).** “Automatic tractor steering.” Ag. Eng., July: **407-409**.

**Louis Toft, M.Sc and A.T.S. Kersey (1938).** “Theory of Machines.” London, Sir. Isaac. Pitman & Sons, Ltd. : **360-363**.

**Gurevich, A.; and Sorokin, E. (1976).** “Tractors.” Mir. Pub., Moscow: 13-16.

**Smith, L.A.; L. Schafer; and R.E. Young (1985).** “Control algorithms for tractor implement guidance.” Trans. ASAE: **415-419**.

**Smith, L.A.; Robertl Schafer; and Alvin C. Bailey (1987).** “Verification of tractor guidance Algorithms.” Trans. ASAE, 30 (2): 305-310.

**Whitaker J.H. (1976).** “Steering design for adjustable tread-width tractors.” Trans. ASAE : **422-427**.

**Zhang, Y. (1985).** “Kinematic analysis and design of tractor steering systems.” Unpub. M. Sc. Th. Univ. of Saskatchewan. Saskatoon, Canada: **116-121**.

**Zhang, Y.; R.L. Kushwaha; and F.W. Bigshy (1988a).** “Analysis of Coplanar and Independent tractor- steering systems.” Trans. ASAE, Vol. **31(4): 1010-1014**.

**Zhang, Y.; R.L. Kushwaha; and F.W. Bigsby (1988b).** “Design of common-center-steering systems of tractors.” Trans. ASAE, Vol.31 (4): 1015-1019.

## المخلص العربي

### دراسة على كفاءة أجهزة توجيه الجرارات الزراعية 1- زوايا التوجيه

أبو الخير مصطفى محمد سرحان\* حسني سلطان القطري\*\* العوضي, م. ن.\*\*\*

تهدف هذه الدراسة إلى معرفة النظام الأمثل لتشغيل وصيانة الجرار الزراعي بصفة عامة والتوجيه والقيادة بصفة خاصة وبالتالي تصميم جهاز توجيه آلي يتم تشغيله بطريقة هيدروليكية بحيث تعمل كوحدة مدمجة تحت جميع خطوات التشغيل ونقل الحركة إلى عجلتي الأرض الأماميتين لتكون ذاتية التوجيه وذلك في الجرار الزراعي.

ولتحقيق هذا الهدف تم اختيار جرارين من نفس النوع ومحراث 7 سلاح صناعة محلية والجرار المستخدم ماركة Belarus (10M3-6KM) ذات قدرة متوسطة لجميع الأغراض 65 حصان ميكانيكي (48.2 كيلوات) شائع الاستخدام تحت الظروف المصرية وأختبر ليناسب الفلاح المصري والمزارع المصرية وأستعمل الجرار قبل وبعد التعديل (وهذا التعديل يسمح بتقليل نصف قطر الدوران من 5 إلى 1.5 متر وكذلك تخفيض الاحتكاك بين العجلات الأمامية وأجهزة التوجيه) أختبر في معمل أبحاث الآلات والجرارات الزراعية بقسم الهندسة الزراعية كلية الزراعة- جامعة الأزهر.

ويمكن تلخيص أهم النتائج المتحصل عليها فيما يلي:

#### 1- تأثير زوايا توجيه العجل الأمامي الداخلية على زوايا توجيه:

1- زوايا توجيه العجل الأمامي الخارجية المثالية تزداد بزيادة زوايا توجيه العجل الأمامي الداخلية وبينما هذه الزوايا تقل بزيادة قيم  $W/WB$  (المسافة بين محور العجلتين الأماميتين وقاعدة العجل الأمامي والعجل الخلفي) وقيمتها تتراوح بين (36.75-43.90 درجة) عند قيم  $W/WB$  (0.2-0.5) على الترتيب.

2- زوايا توجيه العجل الأمامي الخارجية الفعلية والمثالية تزداد بزيادة زوايا توجيه الداخلية وقيمتها الفعلية تتراوح بين (1.95-90.79 درجة) وقيمتها المثالية (1.97-37.74 درجة) عند زوايا داخلية بين (2-50 درجة) على الترتيب.

#### 2- تأثير طول الأسطوانة على زوايا التوجيه:

زوايا توجيه العجل الأمامي الداخلية والخارجية المثالية تزداد بزيادة طول الأسطوانة الهيدروليكية وقيم الزوايا الداخلية تتراوح بين (21.68-68.82 درجة) وقيم الزوايا الخارجية (18.82-45.95 درجة) عند طول أسطوانة يتراوح بين (58.9-70.4 سم) وبينما هذه الزوايا تقل بزيادة قيم  $W/WB$  وقيم الزوايا الداخلية تتراوح من (32.13-44.32 درجة) وقيم الزوايا الخارجية (24.48-35.09 درجة) عند قيم  $W/WB$  تتراوح بين (0.39-0.58) على الترتيب, مما يؤدي إلى زيادة كفاءة الجرار.

\*طالب دراسات عليا، درجة الدكتوراه، ق. هـ. ز. - ك. ز. - ج. الأزهر. \*\*أستاذ الهندسة الزراعية، هـ. ز. - ك. ز. - ج. الأزهر \*\*\*أستاذ منفرغ - هـ. ز. - ك. ز. - ج. عين شمس.