

EFFECT OF VIBRATORY CHISEL PLOW ON POWER REQUIREMENTS AND SOIL PHYSICAL PROPERTIES

M.A. Aboamera⁽¹⁾, M.A. Abd El-Maksoud⁽¹⁾, A.S. El-Kot⁽²⁾
and A.A. Meselhy⁽²⁾

⁽¹⁾ Agric. Engi. Dep. Fac. of Ag. Menoufiya U.

⁽²⁾ Agric – soil Cons. Dep. – Desert Research Center.

(Received: Jan. 13 , 2009)

ABSTRACT: *The aim of this research was to study the effect of vibratory chisel tool on soil physical properties, power requirements and grain wheat yield compared with traditional chisel plow (without vibration). A mathematical model on Matlab program version-7 was built to predict the power requirements for both traditional chisel plow and vibratory chisel plow. Two field experiments were carried out to verify the proposed model. First one was conducted by chisel plow without causing vibration to the shanks (fixed shanks) at three levels of forward speed (1.98, 2.70 and 3.42 km/h). The second was conducted by chisel plow while causing vibration to the shanks at the same levels of forward speed with three levels of angular velocity (50, 55 and 60 cycle/sec) and three levels amplitude (0.06, 0.07 and 0.08 m). The results indicated that using of vibrated shanks of the chisel plow lead to improving soil physical properties, increasing wheat crop yield and decreasing both of total cost and power requirements per wheat crop yield. However, increasing the power consumption was due to the additional consuming of power in vibrated shanks compared with traditional chisel plow (without vibration). Applying the mathematical model, which was built by Matlab, program proved higher efficiency in predicting the power requirements for chisel plow (with vibration and without vibration) where, the correlation coefficient (R^2) was 0.95 between both the measured and predicted values.*

Key words: *Vibratory chisel plow – Mathematical model – Power requirements – Soil physical properties – Total required cost with vibratory tillage.*

INTRODUCTION

Energy conservation in agricultural operation is becoming increasingly important for the viability of the modern agricultural

List of symbols

P_c	Power requirements for chisel unit	(kW)
P_{Cv}	Power requirements for chisel unit with vibration	(kW)
ρ	The unit weight of soil (Specific weight)	(kN/m ³)

ϕ	Angle of the internal friction of soil	(degree)
β	Angle of soil shear plane	(degree)
α	Rake angle of tool (attack angle)	(degree)
A_2	Area of the soil slice side	(m ²)
W	Weight of the soil slice	(kN)
d_1	Depth of soil disturbed (the effective depth)	(m)
b	Chisel blade width	(m)
d	Chisel tool depth (the operating depth)	(m)
V_0	Volume of the soil slice	(m ³)
g	Acceleration due to gravity	m/sec ²
C	Cohesion stress of the soil	(kpa)
A_1	Area of shear failure surface	(m ²)
F_a	Acceleration force (Inertial force)	(kN)
δ	Angle of the soil-metal friction	(degree)
μ	Coefficient of internal soil friction	
μ'	Coefficient of soil-metal friction	
A_0	Chisel tool area	(m ²)
C_a	Adhesion stress	(kpa)
N_2	The forces due to earth pressure on the sides of soil slice	(kN)
K_0	Coefficient of passive earth pressure	
L	Oscillatory amplitude	(m)
F_0	Driving force	(kN)
ϕ^1	Phase angle	(degree)
ω^1	Driving force frequency	(degree)
n	Number of shanks	
k	Stiffness of the frame	(N/m)
m	Mass of dynamic system	(kg)
x	Damping coefficient	(N.s/m)
ω_n	Undamped natural frequency of system	(rad/sec)
x_i	The mean weight diameter of each fractions	(mm)
w_i	The mass of the soil retained on i^{th} -sieve	(gm)
w_T	The total mass of the soil retained on the sieves	(gm)
ε_i	Sieve mesh	
i	Number of sieves	
PR	Power requirements from fuel consumption	(kW)
F_c	Fuel consumption rate	(L/h)
ρ_f	Density of the fuel, (for diesel oil = 0.85 kg/L)	(kg/L)
C.V	Calorific value of fuel	(kcal/kg)
427	Thermal- Mechanical equivalent	(kg.m/kcal)
η_{th}	Thermal efficiency of the engine (assumed to be 40 % for diesel engine)	%
η_m	Mechaical efficiency of the engine	%

Effect of vibratory chisel plow on power requirements and soil.....

<i>Ps</i>	Power consumed by slip	(kW)
<i>NP</i>	Net drawbars pull	(kN)
<i>RR</i>	Rolling resistance	(kN)
<i>V</i>	Forward speed	(m / sec)
<i>S</i>	Slip percentage	%
<i>Prr</i>	Power consumed by rolling resistance	(kW)
<i>Pt</i>	power consumed by transmission system	(kW)
<i>C</i>	Hourly cost	(L.E./h)
<i>p</i>	Price of machine	(L.E.)
<i>h</i>	Yearly working hours	(h/year)
<i>a</i>	Life expectancy of the tractor	(year)
<i>i</i>	Interest	per/(year)
<i>t</i>	Taxes, over head ratio	(%)
<i>r</i>	Repairs and maintenance ratio	(%)
<i>F</i>	Fuel price	(L.E./L)
<i>m</i>	The monthly average wage	(L.E./month)
0.9	Factor accounting for lubrications	
<i>Z</i>	Engine power	(HP)
<i>S</i>	Specific fuel consumption	(kg/hp.h)
<i>A</i>	Amplitude	(m)
<i>F_r</i>	Driving force frequency	(cycle/sec)
<i>A.F.C</i>	Actual field capacity	(Fed/h)
<i>F.E.</i>	Field efficiency	(%)
<i>R.T.V.</i>	Rate of tilled soil volume	(%)
<i>S.B.D.</i>	Soil bulk density	(gm/cm ³)
<i>S.P.</i>	Soil porosity	(%)
<i>M.W.D.</i>	Mean weight diameter	(mm)
<i>F.C.</i>	Fuel consumption	(L/h)
<i>T.S.</i>	Tractor slippage	(%)
<i>P.F.</i>	Pulling force	(kN)
<i>M.P.</i>	Measurement power	(kW)
<i>T.P.</i>	Theoretical power	(kW)
<i>S.E.</i>	Specific energy	(kW.h/fed)
<i>W.G.Y.</i>	Wheat grain yield	(Mg/fed)
<i>T.C.</i>	Total cost of unit area	(L.E./fed)
<i>E.M.Y.</i>	Energy required per mass unit yield	(kW.h/Mg)
<i>S.C.P.</i>	Specific cost of production	(L.E./Mg)

Industry. Vibratory tillage operation has been investigated for the possibility to realize more effective soil cutting. The use of vibration to reduce the force needed to drive piles into the ground was first in 1935 in Russian (*Buston and MacIntyre, 1981*).

Since the early 1950 the interest of the application of vibration in soil cutting and tillage machinery increased. Experimental work, mainly in soil

bins, has concentrated on demonstrating the level of draft reduction that can be achieved, and relating this to the vibration parameters. It was recognized early that there are some changes in the physical properties of the soil near the zone of vibration due to vibratory loading.

Sulatsky and Ukrainetz (1972) reported that, the draft force reduction as high as 80% was achieved when the blade was vibrated. Generally, the overall power required to vibrate and pull the blade through the soil was greater than required to pull a static blade under the same conditions. Yow and Smith, (1978) reported that, forced vibration reduces the draft force of a tillage tool when the maximum velocity of oscillation is higher than the velocity of the tool carrier. For vibratory tillage, the power requirement is higher because additional power is required to oscillate the tool and to increase soil pulverization. Volkov and Volkov, (1980) mentioned that, the degree of breakdown of furrow slice depended on the forward speed and oscillation parameters of the tool. The frequency of oscillation was found to have a greater effect than the amplitude when the oscillation rate exceeded the forward speed. Butson and MacIntyre (1981) revealed a reduction in draft could be achieved when the ratio of forward speed of the tool to the peak vibration velocity was less than one. Saqib et al., (1982) reported that, greater clod size reduction was generally achieved at higher frequencies and amplitudes of vibration and at lower forward velocities. Gupta and Rajput (1992) reported that, the oscillating tillage tool produced smaller soil aggregates than a non-oscillating one. At a given amplitude of oscillations, at any frequency, soil break-up increased with increase in amplitude. Szabo et al., (1994) mentioned that, about 93% draft force reduction was achieved compared with the conventional quasi static counterparts. The combination of vibratory frequency and amplitude significantly affected draft force reduction. Zhang and Kushwaha, (1997) reported that, oscillatory operation generally resulted in a reduction of average soil cutting resistance. However, the draft reduction was achieved at increase of the overall power requirement. The energy consumption for the soil cutting portion decreased as the vibratory frequency and amplitude increased. The energy needed to drive the vibrator increased with the increase of the vibratory frequency and amplitude. The total energy consumption can be minimized by selecting a proper frequency and amplitude of the oscillatory system. Kuczewski and Piotrowska, (1998) found that, a forced vibrating tine will give a substantial reduction in the soil cutting resistance and thereby give a reduction in draught force requirement. Bandalan et al. (1999) concluded that, the oscillating tillage reduces draft for breaking soil, reduces soil compaction and promotes the use of lighter tractors by utilizing tractor power-take-off (p.t.o.) power to achieve higher efficiency of power transmission. Tanya and Salokhe (2000) found that, the amount of soil fragments in the failure zone increased with the increase of tool the oscillating frequency. Niyamapa and Salokhe, (2000) reported that, forces acting on the vibration tillage tool

decreased with an increase in oscillating frequency and oscillating amplitude. The soil surface was cracked due to tool motion showing the characteristics of lifting up of soil clods during the oscillating operation, whereas it showed the characteristics of soil flow during non-oscillating operation. The soil was pulverized more due to oscillating than non-oscillating operation. The reduction in dry bulk density of soil mass in the oscillating operation was about 70-270% more than that during the non-oscillating mode. Gupta and Rajput, (2003) mentioned that, the oscillating tillage tool produced smaller soil aggregates (MWD, mean weight diameter) than a non-oscillating one. At a given amplitude of oscillations, increase in frequency increases soil break-up further. At any frequency, soil break-up increased with the increase in amplitude. Joseph et al., (2007) reported that, applying vibratory motion in the longitudinal direction of a scaled bulldozer blade, a moldboard plow, and a chisel plow resulted in draft force reduction ranged between 71 to 93 % these results were verified on several soil types and conditions ranging from dry (0% moisture d.b.) sands to highly cohesive wet clays. The significant force reduction factors suggest that the vibrating blade reduces soil strength by decreasing cohesiveness and effective stress for dry to ductile soils. The frequency dependency of the soil resistance indicates that the mechanical power delivered to the soil is also a function of the frequency.

The objectives of this work were to investigate the effect of using vibratory chisel tool on physical soil properties, power requirements and grain wheat yield compared with traditional chisel plow. Also to build a mathematical model to predict the power requirements for traditional and vibratory chisel plow.

MATERIALS AND METHODS

All field experiments were carried out in Maryut Experimental Station, Desert Research Center. Tillage operation for all treatments was conducted at 20 cm depth and 20% of soil moisture content (dry base, d.b.) and the optimum soil moisture content was 21.4% d.b and the soil texture is sandy clay loam.

Chisel plough and Tractors

Two tractors (Ursus C-385) were used each has 4 cylinders diesel engine of 51.5 kW (70 HP). The chisel plow consists of four shanks constructed from steel (cross section 2.5 x 7 cm). Each fixed on a carrier and mounted to the tool share. The type of blades is the shovel share. And the shanks provided with four frequencies as shown in Figure (1). The vibration movement driven by P.T.O shaft.

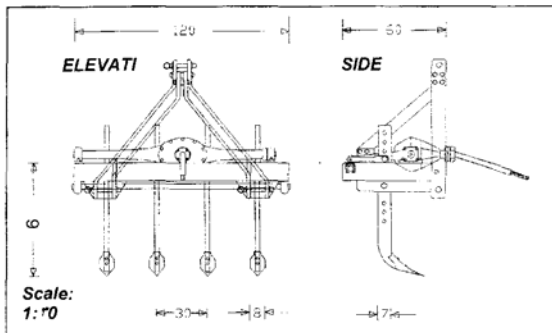

Figure (1): Vibration shanks.

Draft force

Draft force was measured by hydraulic dynamometer coupled between the two tractors with the attaching chisel plough to estimate its draught force. A considerable number of readings were taken at a time interval 10 seconds to obtain an accurate average of draft force. The hitch was always adjusted in order to keep the line of pull as horizontal as possible.

Soil bulk density and soil porosity

Soil bulk density was measured using a core samples (Three replicates for each sample) and the soil porosities were calculated according to *Black et al (1965)* method.

Mean weight diameter (M.W.D.)

The soil mean weight diameter (*M.W.D*) was determined according to *Van Bavel, (1949)* as follow:

$$M.W.D. = \sum_{i=1}^{i=n} \frac{X_i W_i}{W_T} \dots \dots \dots (1)$$

where: $X_i = \frac{\epsilon_{i-1} - \epsilon_i}{2}$

Theoretical and actual field capacity and field efficiency

Theoretical and actual field capacity and field efficiency were calculated by using equations mentioned by *kepner et al, (1978)*.

Tractor wheel slip

Slip percentages were calculated using the standard method of measuring distances traveled with and without load for a certain number of wheel revolutions.

Fuel consumption rate

Fuel consumption per unit time was determined by measuring the volume of fuel consumed during plowing time. It was calculated using the fuel meter equipment as shown in Figure (2). The length of line which marked by the marker tool on the paper sheet represents the fuel consumption. The fuel meter was calibrated prior and the volume of fuel was determined accurately.

Power requirements

(a) Power requirements from fuel consumption

Power requirements determined for each operation as follows (*Taieb, 1990*):

$$PR = \left(F_c \times \frac{1}{3600} \right) \times \rho_f \times C.V \times 427 \times \eta_{th} \times \eta_m \times \frac{1}{75} \times \frac{1}{1.36} \dots\dots(2)$$

(b) Power consumed by slip

The power consumed by slip was calculated as follows:

$$P_s = (NP + RR) \times V \times S \quad (\text{El-Sayed and Rushdi, 2002})\dots\dots(3)$$

(c) Power consumed by rolling resistance

The power consumed by rolling resistance was calculated as follows:

$$P_{rr} = RR \times V \quad (\text{El-Sayed and Rushdi, 2002})\dots\dots(4)$$

(d) Power consumed by transmission system

The power consumed by transmission system was calculated as follows:

$$P_t = (1 - \text{transmission system efficiency}) \times (\text{net engine power})\dots(5)$$

(*El-Sayed and Rushdi, 2002*)

(e) Power requirement for mechanical operations (Pc)

The power requirement was calculated as follows:

$$P_c = PR - P_{rr} - P_s - P_t \dots\dots(6)$$

Specific energy

The specific energy (kw.h/fed) for a particular operation calculated as follows:

$$S.E = PR / A.F.C \dots\dots(7)$$

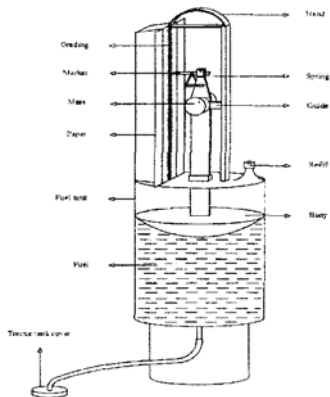
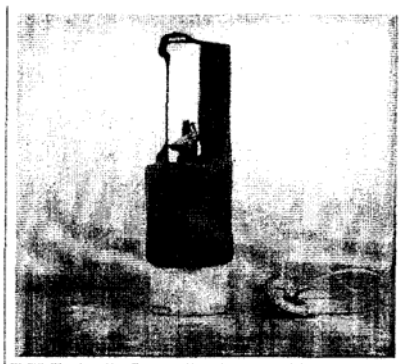

Figure (2): Fuel meter for measuring fuel consumption.

Effect of vibratory chisel plow on power requirements and soil.....

Total cost of performing a preparing operation

An equation, developed by *EL-Awady (1978)* was used for determining the total hourly cost of tillage operation as follows:

$$C = \left(\frac{p}{h}\right) \cdot \left(\frac{1}{n} + \frac{i}{2} + t + r\right) + (0.9 \cdot Z \cdot S \cdot f) + \left(\frac{m}{144}\right) \dots\dots\dots (8)$$

Total cost per unit area

Total cost per unit area was determined as follows:

$$T.C. = C / A_{tc} \dots\dots\dots (9)$$

Energy required per mass unit yield

Energy required per mass unit yield was determined from the following equation:

$$E.R.Y = SE / Y \dots\dots\dots (10)$$

Specific cost of production

Specific cost of production was determined as follows:

$$S.C.P = TCA / Y \dots\dots\dots (11)$$

Tillage energy required per unit mass of yield

Tillage energy required per unit weight of yield (kW.h/Mg) was calculated by dividing the specific tillage energy (SE) (kW.h/fed) by the crop yield (Y) (Mg/fed).

Specific cost of unit mass of yield

Specific cost of unit weight of yield (L.E/Mg) was calculated by dividing the total cost per unit area (TCO) (L.E/fed) by crop yield (Y) (Mg/fed).

Soil shear strength parameters:

Soil shear strength parameters (cohesion force (C), internal friction angle (ϕ), metal-soil friction angle (δ) and adhesion force (C_a) were measured by direct shear box device (model D-110 Ay, U.S.A.).

Mathematical model for prediction the power requirements

The following mathematical model was built on *Matlab program version-7* to predict the power requirements for fixed and vibratory chisel plow. The flow chart of the proposed model was as shown in *figure (3)* the input data for the mathematical model were represented with their units in *figure (4)*.

RESULTS AND DISCUSSION

The results classified into four groups as follows:

- 1- Field parameters include actual field capacity, field efficiency, rate of tilled soil volume and bulk density.
- 2- Soil parameters, include porosity, mean weight diameter of soil aggregates, fuel consumption and slippage.
- 3- Power parameters, include pull force, measured power, and specific energy and theoretical power.
- 4- Production and cost parameters include, wheat yield, total cost, energy required per unit yield and specific cost of the product.

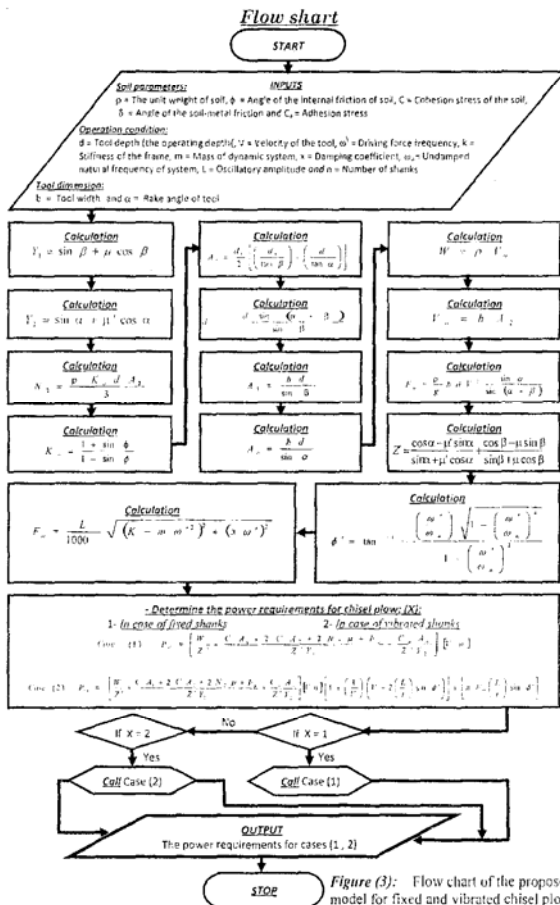

Figure (3): Flow chart of the proposed model for fixed and vibrated chisel plow.

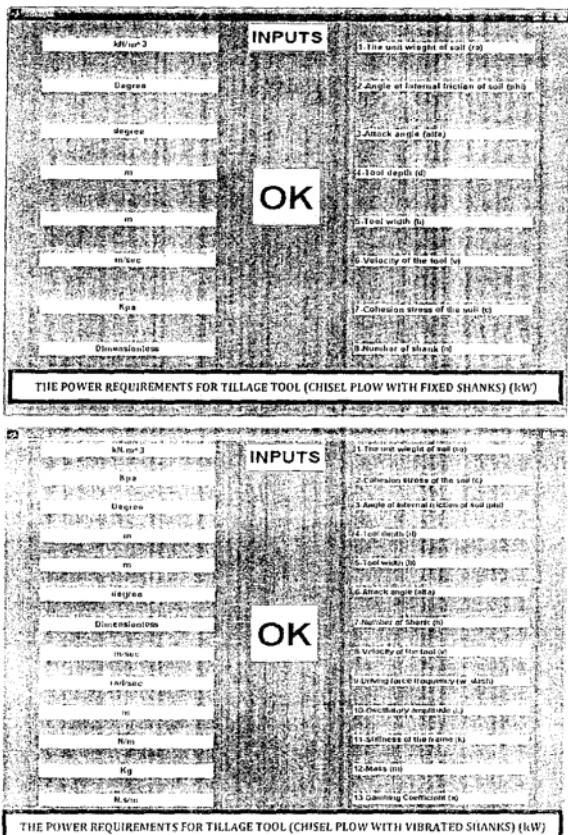

Figure (4): Input data and their measuring units for fixed and vibrated shanks as presented in MATLAB PROGRAM.

1- Effects of forward speed, amplitude and frequency on field parameters

Figure (5) represents the obtained outputs of field parameters at different levels of forward speed, amplitude and frequency for fixed and vibrated shanks.

In general, increasing forward speed caused an increase in actual field capacity, rate of tilled volume and bulk density. The increasing percentages were 36.36% - 26.32%, 36.32% - 24.32% and 6.25% - 4.5% respectively. Field efficiency decreased and the decreasing percentages were 11.34% - 9.5% with fixed and vibrated shanks respectively when forward speed increased from 0.55 to 0.75 m/sec at frequency 50 cycle/sec and amplitude 0.06 m. In case of vibrated shanks, the results showed that, when the amplitude increased the actual field capacity, field efficiency, rate of tilled volume and bulk density increased (The increasing percentages were 8.11%, 6.98%, 15.83% and 5.4% respectively) when amplitude increased from 0.06 to 0.08 m at frequency 50 cycle/sec and forward speed 0.55 m/sec. Similarly when the frequency increased the all previous indicators increased (The increasing percentages were 13.51%, 12.11%, 13.5% and 7.2% respectively) when frequency increased from 50 to 60 cycle/sec at amplitude 0.06 m and forward speed 0.55 m/sec. Also when using vibrated shanks, both of actual field capacity, field efficiency and rate of tilled volume increased

(The increasing percentages were 33.33%, 25.26% and 33.3% respectively) but bulk density decreased (The decreasing percentage was 13.28%) compared with fixed shanks at the same conditions.

The following multiple linear regression equations showed the effect of changing forward speed, frequency for shanks and amplitude for vibration on actual field capacity (A.F.C.), field efficiency (F.E.), rate of tilled volume (R.T.V.) and bulk density (S.B.D.).

In case of fixed shanks

$$\text{A.F.C.} = 0.500 V + 0.062 \dots\dots\dots (R^2 = 0.98).$$

$$\text{F.E.} = - 31.375 V + 78.225 \dots\dots\dots (R^2 = 0.99).$$

$$\text{R.T.V.} = 420.000 V + 51.800 \dots\dots\dots (R^2 = 0.98).$$

$$\text{S.B.D.} = 0.325 V + 1.106 \dots\dots\dots (R^2 = 0.98).$$

In case of vibrated shanks

$$\text{A.F.C.} = 1.8330 A + 0.006 F_r + 0.46100 V - 0.285 \dots\dots\dots (R^2 = 0.99).$$

$$\text{F.E.} = 23.111 A + 0.745 F_r - 27.9860 V + 29.122 \dots\dots\dots (R^2 = 0.99).$$

$$\text{R.T.V.} = 1540.0 A + 4.760 F_r + 387.333 V - 239.478 \dots\dots\dots (R^2 = 0.99).$$

$$\text{S.B.D.} = 3.4440 A + 0.008 F_r + 0.28900 V + 0.355 \dots\dots\dots (R^2 = 0.97).$$

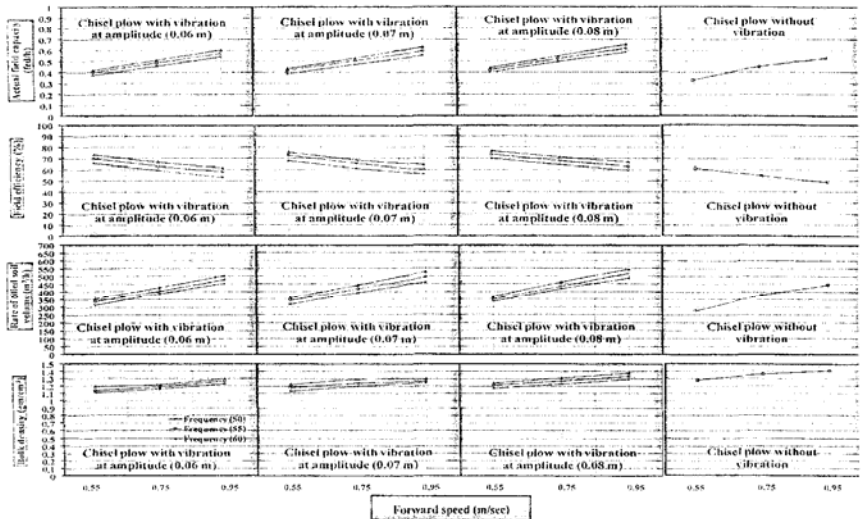

Figure (5): Actual field capacity (fed/h), Field efficiency (%), Rate of tilled volume (m³/h) and Bulk density (gm/cm³) at different levels of amplitude, driving force frequency and forward speed in both fixed and vibrated shanks.

2- Effects of forward speed, amplitude and frequency on soil parameters.

Figure (6) represents the obtained outputs of soil parameters at different levels of forward speed, amplitude and frequency for fixed and vibrated shanks.

In general, increasing forward speed caused a decrease in soil porosity and mean weight diameter. Decreasing percentages were 5.84% - 3.25% and 8.16% - 8.85% respectively. Fuel consumption and tractor slippage increased and increasing percentages were 31.79% - 21.1% and 10.86% - 13.83% with fixed and vibrated shanks respectively when forward speed increased from 0.55 to 0.75 m/sec at frequency 50 cycle/sec and amplitude 0.06 m. On case of vibrated shanks, the results showed that, when the amplitude increased soil porosity, mean weight diameter and tractor slippage decreased (The decreasing percentages were 8.45%, 24.25% and 38.55% respectively) but caused increase in fuel consumption (The increasing percentage was 36.64%) when amplitude increased from 0.06 to 0.08 m at frequency 50 cycle/sec and forward speed 0.55 m/sec. In the other hand when the frequency increased the soil porosity, mean weight diameter, fuel consumption and tractor slippage decreased (decreasing percentages were 5.2%, 11.11%, 21.6% and 22.52% respectively) when frequency increased from 50 to 60 cycle/sec at amplitude 0.06 m and forward speed 0.55 m/sec. Also when using vibrated shanks both of soil porosity and fuel consumption increased (The increasing percentages were 12.42% and 40.54% respectively) but mean weight diameter and tractor slippage decreased (The decreasing percentages were 42.72% and 66% respectively) compared with fixed shanks at same conditions.

The following multiple linear regression equations showed the effect of changing forward speed, frequency for shanks and amplitude for vibration on soil porosity (S.P.), mean weight diameter (M.W.D.), fuel consumption (F.C.) and tractor slippage (T.S.).

In case of fixed shanks

$$\text{S.P.} = -12.25 V + 58.238 \dots\dots\dots (R^2 = 0.98).$$

$$\text{M.W.D.} = -4.325 V + 13.16 \dots\dots\dots (R^2 = 0.99).$$

$$\text{F.C.} = 4.650 V + 1.202 \dots\dots\dots (R^2 = 0.97).$$

$$\text{T.S.} = 5.475 V + 7.307 \dots\dots\dots (R^2 = 0.99).$$

In case of vibrated shanks

$$\text{S.P.} = -130.056 A - 0.289 F_r - 10.897 V + 86.597 \dots\dots (R^2 = 0.97).$$

$$\text{M.W.D.} = -117.000 A - 0.103 F_r - 3.603 V + 23.561 \dots\dots (R^2 = 0.99).$$

$$\text{F.C.} = 88.833 A - 0.195 F_r + 5.528 V + 8.347 \dots\dots (R^2 = 0.97).$$

$$\text{T.S.} = -140.389 A - 0.182 F_r + 5.728 V + 22.243 \dots\dots (R^2 = 0.97).$$

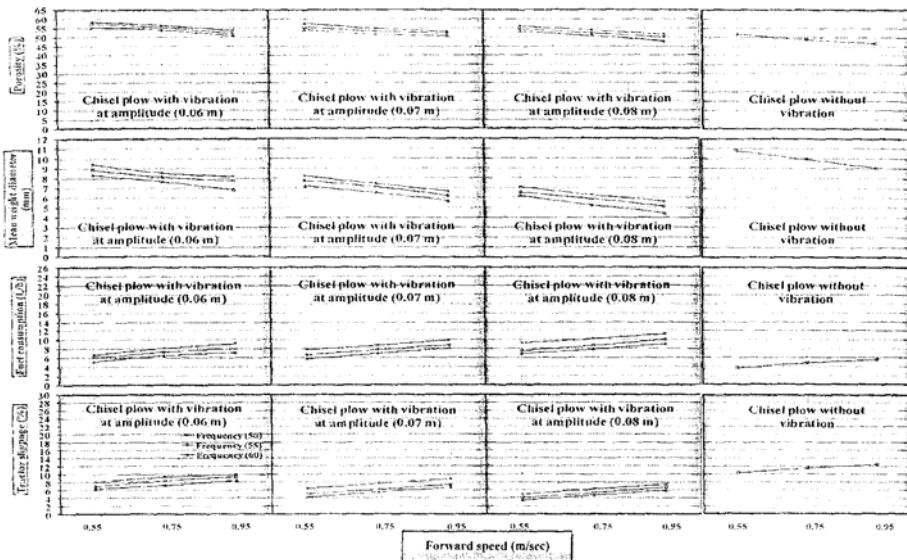

Figure (6): Soil porosity (%), Mean weight diameter (mm), Rate of tilled volume (m³/h) and Tractor slippage (%) at different levels of amplitude, driving force frequency and forward speed in both fixed and vibrated shanks.

3- Effects of forward speed, amplitude and frequency on power parameters.

Figure (7) represents the obtained outputs of power parameters at different levels of forward speed, amplitude and frequency for fixed and vibrated shanks. In general, increasing forward speed caused an increase in pulling force, measured power and theoretical power. The increasing percentages were 15.46% - 17.16%, 27.64% - 17.46% and 35.42% - 29.01% respectively. Specific energy decreased and the decreasing percentages were 3.34% - 2.6% with fixed and vibrated shanks respectively when forward speed increased from 0.55 to 0.75 m/sec at frequency 50 cycle/sec and amplitude 0.06 m. In case of vibrated shanks, the results showed that, when the amplitude increased both of measured power, theoretical power and specific energy increased (The increasing percentages were 43.82%, 40.88% and 26.45% respectively) but caused a decrease in pulling force (The decreasing percentage was 52.92%) when amplitude increased from 0.06 to 0.08 m at frequency 50 cycle/sec and forward speed 0.55 m/sec. On the other hand when the frequency increased the pulling force, measured power, theoretical power and specific energy decreased and the decreasing percentages were 48.1%, 23.34%, 21.32% and 29% respectively when frequency increased from 50 to 60 cycle/sec at amplitude 0.06 m and forward speed 0.55 m/sec. Also when using vibrated shanks, the pulling force decreased (The decreasing percentage was 82.83%) but the measured power, theoretical power and specific energy increased (The increasing percentages were 25.17%, 96% and 15.9% respectively) compared with fixed shanks at the same conditions. The following multiple linear regression equations showed the effect of changing forward speed, frequency for shanks and amplitude for vibration on pulling force (P.F.), measured power (M.P.), theoretical power (T.P.) and specific energy (S.E.).

In case of fixed shanks

$$\begin{aligned} \text{P.F.} &= 6.35 V + 4.718 \dots\dots\dots (R^2 = 0.99). \\ \text{M.P.} &= 5.400V + 3.22 \dots\dots\dots (R^2 = 0.92). \\ \text{T.P.} &= 8.620 V + 0.04 \dots\dots\dots (R^2 = 0.99). \\ \text{S.E.} &= -4.825 V + 33.502 \dots\dots\dots (R^2 = 0.99). \end{aligned}$$

In case of vibrated shanks

$$\begin{aligned} \text{P.F.} &= -103.056 A - 0.361 F_1 + 5.1 V + 28.938 \dots\dots\dots (R^2 = 0.97). \\ \text{M.P.} &= 209.278 A - 0.406 F_1 + 8.358 V + 16.551 \dots\dots\dots (R^2 = 0.97). \\ \text{T.P.} &= 222.333 A - 0.290 F_1 + 17.364 V + 3.551 \dots\dots\dots (R^2 = 0.99). \\ \text{S.E.} &= 339.167 A - 1.611 F_1 - 10.956 V + 117.743 \dots\dots\dots (R^2 = 0.94). \end{aligned}$$

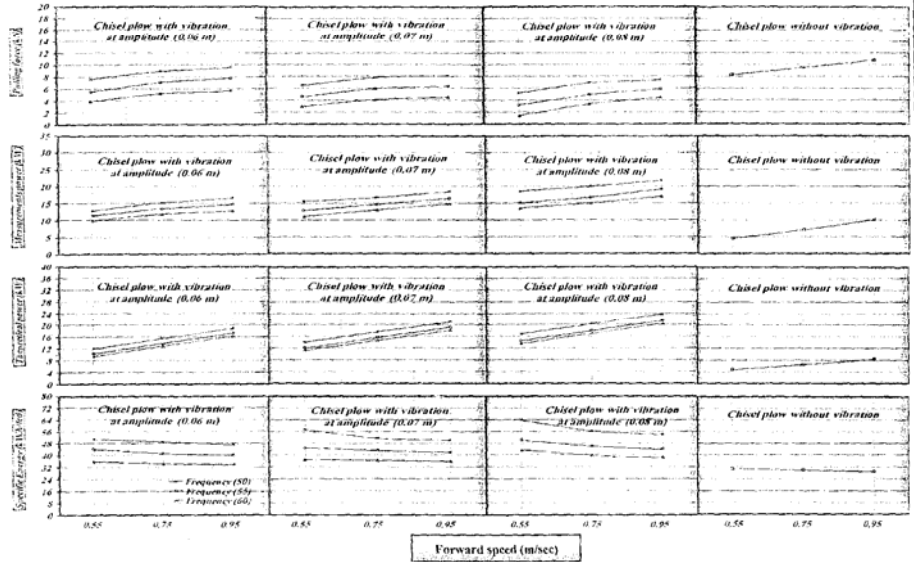

Figure (7): Pulling force (kN), Measurements power (kW), Theoretical power (kW) and Specific energy (kW.h/fed) at different levels of amplitude, driving force frequency and forward speed in both fixed and vibrated shanks.

4- Effects of forward speed, amplitude and frequency on production and cost parameters.

Figure (8) represents the obtained outputs of production and cost parameters at different levels of forward speed, amplitude and frequency for fixed and vibrated shanks. In general, increasing forward speed caused decrease in energy required per mass unit yield and specific cost of production. The decreasing percentages were 13.45% - 4.32% and 14.95% - 5.13% respectively. Wheat grain yield and total cost, increased and the increasing percentages were 11.65% - 17.36% and 11.65% - 17.36% with fixed and vibrated shanks respectively when forward speed increased from 0.55 to 0.75 m/sec at frequency 50 cycle/sec and amplitude 0.06 m. In case of vibrated shanks, the results showed that, when the amplitude increased both of wheat grain yield and total cost increased (The increasing percentages were 44% and 24.85% respectively) but caused decrease in energy required per mass unit yield and specific cost of production (The decreasing percentages were 12.21% and 13.32% respectively) when the amplitude increased from 0.06 to 0.08 m at frequency 50 cycle/sec and forward speed 0.55 m/sec. On the other hand when the frequency increased the total cost, energy required per mass unit yield and specific cost of production decreased (The decreasing percentages were 29.45%, 40.46% and 40.86% respectively) but wheat grain yield increased (The increasing percentage was 19.27%) when frequency increased from 50 to 60 cycle/sec at amplitude 0.06 m and forward speed 0.55 m/sec. Also with the vibrated shanks, both of wheat grain yield and total cost increased (The increasing percentages were 72.81% and 11.94% respectively) but energy required per mass unit yield and specific cost decreased (The decreasing percentages were 18.62% and 21% respectively) compared with fixed shanks at the same conditions. The following multiple linear regression equations showed the effect of changing forward speed, frequency for shanks and amplitude for vibration on wheat grain yield (W.G.Y.), total cost (T.C.), energy required per mass unit yield (E.M.Y.) and specific cost of production (S.C.P.).

In case of fixed shanks

$$\begin{aligned} \text{W.G.Y.} &= 0.575 V + 0.715 \dots\dots\dots (R^2 = 0.99). \\ \text{T.C.} &= - 40.450 V + 210.944 \dots\dots\dots (R^2 = 0.98). \\ \text{E.M.Y.} &= - 17.525 V + 39.434 \dots\dots\dots (R^2 = 0.99). \\ \text{S.C.P.} &= - 115.900 V + 245.97 \dots\dots\dots (R^2 = 0.98). \end{aligned}$$

In case of vibrated shanks

$$\begin{aligned} \text{W.G.Y.} &= 24.000 A + 0.023 F_r + 0.492 V - 1.802 \dots\dots (R^2 = 0.98). \\ \text{T.C.} &= 1917.639 A - 9.255 F_r - 70.507 V + 692.058 \dots (R^2 = 0.95). \\ \text{E.M.Y.} &= - 279.111 A - 1.569 F_r - 17.214 V + 149.15 \dots (R^2 = 0.95). \\ \text{S.C.P.} &= - 1714.778 A - 9.100 F_r - 106.064 V + 880.136 \dots (R^2 = 0.95). \end{aligned}$$

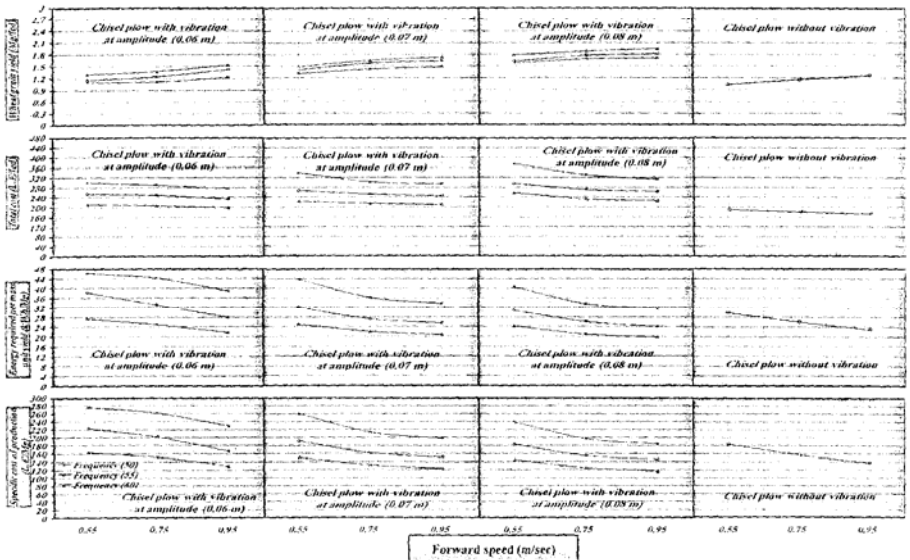

Figure (8): Wheat grain yield (Mg/fed), Total cost (L.E/fed), Energy required per mass unit yield (kW.h/Mg) and Specific cost of production (L.E/Mg) at different levels of amplitude, driving force frequency and forward speed in both fixed and vibrated shanks.

General validation of the mathematical model.

The mathematical model was validated by comparing the theoretically computed values with the experimentally observed values. Measured values were plotted against their predicted values as shown in Figure (9). If there was not discrepancy between the measured data and the predicted results, then all points will lie on a line with a slope of one (*the angle with x-axis is equal 45 degree*) passing through the origin. For each value of power, the deviation percent was calculated according to the following relationship.

$$\text{Deviation (\%)} = (\text{Measured power} - \text{Predicted power}) / \text{Measured power}.$$

The prediction error was calculated by dividing the average deviation percent by the number of values. The prediction error was 9.4%. The higher value of the correlation coefficient ($R^2 = 0.95$) indicates that the predicted values are in close agreement with the experimental data.

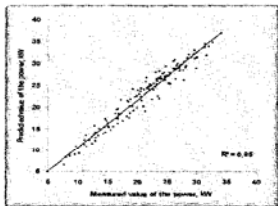

Figure (9): Relationship between predicted and measured values of the

CONCLUSION

The used of vibration shanks of chisel plow lead to improve soil physical properties, increase wheat crop yield and decrease total cost. In spite of consuming a higher power required for causing vibration to the shanks.

The mathematical model which, built by *MATLAB PROGRAM* proved higher efficiency in predicting the power requirements for chisel plow (*with and without vibration*) where, the correlation coefficient (R^2) between the measured and the predicted values was 0.95.

REFERENCES

- Bandalana, E.P., V.M. Salokhe, C.P. Gupta and T. Niyamapab (1999). Performance of an oscillating subsoiler in breaking a hardpan. *Journal of Terramechanics* 36: 117-125.
- Black, C.A., D.D. Evan, J.L. White, L.E. Ensimenger and F.E. Clark (1965). *Methods of soil analysis (Part 1), Physical and Mineralogical properties, including statistics of measurements and sampling*, American Society of Agronomy, Inc., Publisher Madison, Wisconsin, U.S.A. PP: 375-377 and 552-557.

Effect of vibratory chisel plow on power requirements and soil.....

- Buston, M.J. and D. MacIntyre (1981). Vibrating soil cutting 1: Soil tank studies of draught and power requirements. *Journal of Agric. Eng. Res.* 26: 409-418.
- El-Awady, M.N. (1978). *Engineering of Tractor and Agricultural Machinery. Text Book, (in Arabic), Fac. Of Ag., Ain Shams Univ., Cairo, Egypt.*
- El-Sayed, G.H. and M.M. Rushdi (2002). Predicted vs. measured tractor fuel consumption in soil working operations. *Misr J. Ag. Eng.*, 19(1): 268-284.
- Gupta, C.P. and D.S. Rajput (1992). Soil reactions to tillage implements. Final Technical Report of Grant No. FC-In-389, Project No. AT-AE-7. Agricultural Engineering Department, Indian Institute of Technology, Kharagpur, India, pp. 85-90.
- Gupta, C.P. and D.S. Rajput (2003). Effect of amplitude and frequency on soil break-up by an oscillating tillage tool in a soil bin experiment. *Soil & Tillage Research* 25: 329-338.
- Joseph, St., B. Szabo, F. Barnes, S. Sture and H.Y. Ko. (2007). Effectiveness of vibrating bulldozer and plow blade on draft force reduction. *Transactions of the ASAE. VOL. 41(2):283-290.*
- Kepner, R.A., R. Bainer and E.L. Barger (1978). *Principles of farm machinery. Third Edition. AVI Publishing Company, Inc. Westport, Connecticut. U.S.A. P: 186.*
- Kuczewski, L. and E. Piotrowska (1998). An improved model for forces on narrow soil cutting tines. *Soil Till. Res.* 46, 231-239.
- Niyamapa, T. and V.M. Salokhe (2000). Force and pressure distribution under vibratory tillage tool. *Jou. of Terramechanics* 37:139-150.
- Saqib, G.S., M.E. Wright and T.R. Way (1982). Clod size reduction by vibratory diggers. *ASAE No. 82-1546. St. Joseph, MI, 16 pp.*
- Sulatsky, M.T. and P.R. Ukrainetz (1972). Draft reduction by vibratory soil cutting. *Transaction of the Canadian Society of Mechanical Engineering* 1(4): 175-181.
- Szabo, B., F. Barnes, S. Sture and H.Y. Ko. (1994). Effectiveness of vibrating bulldozer and plow blade on draft force reduction. *ASAE Paper No. 941535. St. Joseph. MI: ASAE.*
- Taieb, A.Z. (1990). *The demand and constraints of energy utilization in sugarbeet crop production. Cairo Univ. Ph. D., (Agric., Eng.).*
- Tanya and V.M. Salokhe (2000). Soil disturbance and force mechanics of vibrating tillage tool. *Journal of Terramechanics* 37, 151-166.
- Van Bavel, C.H.M. (1949). Mean weight diameter of soil aggregates as a statistical index of aggregation. *Soil Science Society of America Proceedings* 14:20-23.
- Volkov, E.T. and A.T. Volkov (1980). Oscillation and the efficiency of crushing the soil slice. *Sb.Nauchn. Tr.Voigograd. Sel.Inst.,74:3-7.*
- Yow, J. and J.L. Smith (1978). Sinusoidal vibratory tillage. *Journal of Terramechanics* 13(4):211-26.
- Zhang, J. and R.L. Kushwaha (1997). A modified model to predict soil cutting resistance. *Soil & Tillage Research* 34: 157-168.

تأثير المحراث الحفار الاهتزازى على أحتياجات القدرة والخواص الطبيعية للتربة

د/ محمد على حسن ابو عميرة^(١) ، محمد عبد الفتاح عبد المقصود^(٢) ،
أحمد سعيد القط^(٢) ، عادل عبد السميع مصيلحي^(٢)

^(١) قسم الهندسة الزراعية - كلية الزراعة - جامعة المنوفية.

^(٢) قسم صيانة الأراضي - مركز بحوث الصحراء.

الملخص العربى

أجرى هذا البحث بهدف دراسة تأثير استخدام أداة الحرث الاهتزازى لقصبات المحراث الحفار على الخواص الطبيعية للتربة وأحتياجات القدرة وأنتاجية محصول القمح بالمقارنة مع المحارث الحفارة التقليدية (بدون أحداث اهتزاز لقصبات المحراث). ولتحقيق هذا الهدف تم بناء نموذج رياضى على برنامج الماتلاب (MATLAB) للتنبؤ بأحتياجات القدرة للمحراث الحفار سواء عند أحداث إهتزاز لقصبات او بدون أهتزاز. وقد أجريت تجربتين حقليتين بمحطة بحوث مريوط التابعة لمركز بحوث الصحراء. التجربة (الأولى) أستخدم فيها المحراث الحفار التقليدى بدون اهتزاز فى عملية اعداد التربة قبل الزراعة عند سرعات أمامية (١.٩٨ كم/ساعة - ٢.٧٠ كم/ساعة - ٣.٤٢ كم/ساعة). و التجربة (الثانية) أستخدم فيها المحراث الحفار مع أحداث اهتزاز لقصبات المحراث فى عملية اعداد التربة قبل الزراعة عند نفس السرعات الامامية السابقة مع اتساع اهتزاز مقدارة (٠.٠٦ متر ، ٠.٠٧ متر ، ٠.٠٨ متر). و تردد قيمته (٥٠ دورة/ثانية ، ٥٥ دورة/ثانية ، ٦٠ دورة/ثانية). وتوصلت الدراسة الى النتائج الآتية:

١- زيادة السرعة الامامية للحرث من ١.٩٨ الى ٢.٧٠ كم/ساعة وعند تردد مقدارة ٥٠ دورة/ثانية أدى الى زيادة كل من السعة الحقلية الفعلية ومعدل الحجم المحروث من التربة والكثافة الظاهرية للتربة بنسبة ٢٦.٣٢% ، ٢٤.٣٢% ، ٤.٥% على الترتيب عند استخدام أداة الحرث الاهتزازى.

Effect of vibratory chisel plow on power requirements and soil.....

- ٢-تحققنت نسبة زيادة فى قوة الشد والقدرة المقاسة والقدرة النظرية بمقدار ١٧.١٦% , ١٧.٤٦% , ٢٩% على الترتيب عند استخدام أداة الحرث الاهتزازى ويزيادة السرعة الامامية من ١.٩٨ الى ٢.٧٠ كم/ساعة وتردد مقدارة ٥٠ دورة/ثانية وسعة اهتزاز مقدارها ٠.٠٦ متر .
- ٣-قلت الطاقة المطلوبة لوحدة الوزن من الأنتاج والتكاليف النوعية للمنتج بمقدار ١٨.٦٢% , ٢١% على الترتيب باستخدام أداة الحرث الاهتزازى .
- ٤-اثبت استخدام النموذج الرياضى الذى تم بناؤه على برنامج الماتلاب كفاءة عالية فى التنبؤ بأحتياجات القدرة للمحراث الحفار سواء عند استخدام الاهتزاز لقصبات المحراث او عند الحرث التقليدى حيث بلغت قيمة معامل الارتباط (R^2) بين القيم المقاسة والقيم المتوقعة بواسطة النموذج الرياضى حوالى ٠.٩٥ .