

AFFECTING FACTORS ON PERFORMANCE OF A DEVELOPED HOLE DIGGER

Yehia, I. ; M. H. Kabeel and S. K. Khalil
Ag. Eng. Res. Institute, ARC.

ABSTRACT

The aim of this research was the studying of some factors affecting the development of a hole digger. The experiments were conducted in El Gemiza Research Station in Gharbia Governorate. Three auger diameters (150, 200 and 250 mm) of the developed hole-digger were tested at different auger-speeds (75, 100 and 150 rpm), auger pitches (10, 15 and 20 cm), hole-depths (20, 30 and 40 cm), hole-spacing (5 m) and soil type (clay) with moisture contents of 18, 22 and 26% and (bulk densities of 1.2, 1.1 and 1.05 g/cm³).

The obtained results can be summarized as follows:

The maximum hole productivity was 324 hole/h obtained with auger speed of 150 rpm, hole diameter 15 cm, hole depth 20 cm, auger pitch 20 cm at moisture content 26%. The penetration resistance of clay soil at 18 % moisture content increased by 35 and 45 % as compared with of clay soil at moisture content 22 % and 26 % respectively. The maximum fuel consumption was 0.69 L/h was obtained with auger speed of 150 rpm, hole diameter 25 cm, hole depth 40 cm, and auger pitch 10 cm. The maximum power requirements (2.72 kW) was obtained with auger speed of 150 rpm, hole diameter 25 cm, hole depth 40 cm, auger pitch 10 cm and moisture content 18 %. The minimum operation cost was 0.05 L.E./hole at auger diameter 15 cm, auger pitch 15 cm and hole depth 20 cm. Whereas, the maximum operation cost was 0.23 L.E./hole at auger diameter 25 cm, auger pitch 10 cm and hole depth 40 cm. The operational cost using a hole digger attached to a power tiller decreased by 500-950 % compared with manual digging.

INTRODUCTION

The greatest two environmental problems in the world are the desertification due to cutting the forest trees for wood and sand movement from desert to cultivated lands. These problems could be solved by cultivation and tree planting.

Governments take care of tree-planting projects for windbreaks, minimizing of air pollution.

Various agricultural machines were manufactured to save time and effort, and to protect the environment. The hole digger is one of the most important machines used in these objectives. The devolved machine must be not expensive, simple in construction and work in all environmental conditions.

Kapnehko et al. (1976) recommended a hole digger of 30 - 100 cm diameter at penetration speed 1 - 25 cm / s to establish holes for apples. The consumed time was found to be 8, 9 and 12 - 20 s for diameters of 30, 60 and 80 - 100 cm respectively. The hole digger establishes 100 - 150 hole / h for a depth of 60 cm at speed of 180 rpm.

Purtskhvanidze and Keller (1990) tested a hole digger for making on-slopes attachment to a hand-operated tractor 2 kW. They found the tractor saved about 20 – 30 % in power consumption.

El Shal (1993) found that the digging efficiency of hole digger increased with increasing the hole depth, hole diameter, resistance and moisture content of soil. The maximum digging efficiency of 94 % was obtained by using hole diameter of 60 cm, hole depth 100 cm and moisture content 26 % in loamy soil. Meanwhile, the minimum digging efficiency of 64 % was obtained by using hole diameter of 40 cm, hole depth 50 cm and moisture content 11 % in sandy soil.

It is aimed in this study to design, construct and test a hole digger attached to a power tiller by considering the following points:

- Minimizing the energy consumption by using small power tractor and consequently saving in fuel consumption.
- Using modern technologies in tree-planting to reduce the effort and labors work.
- Saving the time and minimizing the cost of production.

Chaaban et al. (2007) and Khalil (2008) designed and tested a hole digger attached to power tiller. They found that the maximum hole-productivity of 57 hole/h was obtained with auger speed of 200 rpm (1.58 m/s), auger pitch of 100 mm (average penetration-angle of 13°), hole diameter 15 cm, hole depth 20 cm, hole spacing 1 m and sandy soil with moisture content 13 %. Whereas the minimum hole-productivity of 14 hole/h was obtained with auger speed of 75 rpm (1.2 m/s), auger pitch of 100 mm (average penetration-angle of 13°), hole diameter 30 cm, hole depth 40 cm, hole spacing 5 m and loamy soil with moisture content 18 %. The power requirements of the designed machine increased with increasing auger diameter, auger speed, hole depth, hole spacing and soil resistance. The maximum power requirements of 3.3 kW was obtained with auger speed of 200 rpm (3.1 m/s at outer cutting edge), hole diameter 30 cm, hole depth 40 cm, hole spacing 5 m in loamy soil. Meanwhile the minimum power requirements of 1 kW was obtained with auger speed of 75 rpm (0.58 m/s at outer cutting edge), hole diameter 15 cm, hole depth 20 cm, hole spacing 1 m and sandy soil.

The objective of this work is to study the affecting factors on performance of a developed hole digger (which designed by Chaaban et al., 2007 and Khalil, 2008) such as auger pitch, diameter and speed and moisture content of clay soil in order to improve the performance of this implement.

MATERIALS AND METHODS

1- Materials:

(1) Experimental site: The experiments were carried out during years 2008 and 2009 in Gemmiza Research Stations, clay soil, at moisture contents of 18, 22 and 26 %. The mechanical analysis of the experimental soil was classified as clay soil as shown in table 1.

Table 1: Mechanical analysis of the experimental soil.

| Soil Depth | Clay, %. | Silt, %. | Sand, %. | Soil Texture class |
|------------|----------|----------|----------|--------------------|
| 0 – 40 cm | 44.2 | 38.6 | 17.2 | Clay |

(2) The developed hole-digger: The developed hole digger (which designed by Chaaban et al., 2007 and Khalil, 2008) is shown in fig. 1. The developed hole-digger consists of the following parts:

(a) Frame: The frame was made of square-section steel tubing with dimensions of 80 X 80 mm, with thickness of 3 mm. The total length of frame is 375 mm and width is 355 mm. The height of frame from soil level is 525 mm.

(b) Two stands with ground wheels: Two stands and two ground wheels carry the frame and all parts of the designed hole digger. Each stand was made of square-pipe steel of 50 X 50 mm, with thickness of 3 mm. The total length of stand is 550 mm. The distance between two stands is 400 mm. Two plastic ground-wheels were attached with the bottom of stands by two pins. The diameter of each ground wheel is 200 mm and the width is 45 mm.

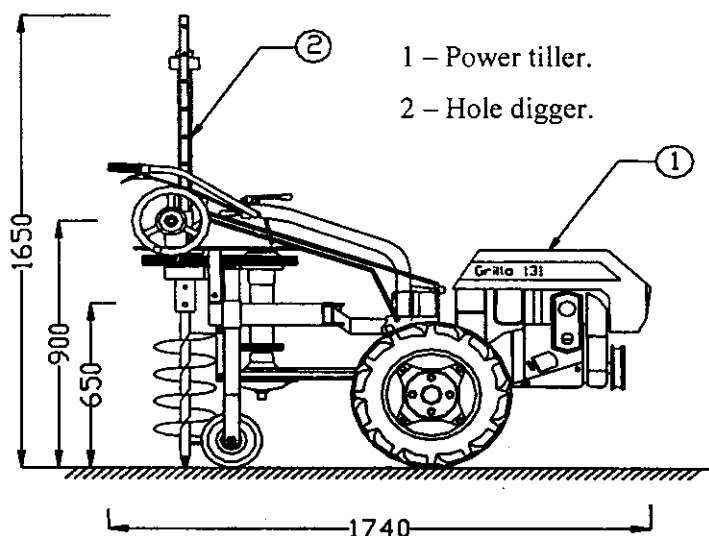

Fig. 1: View of the developed hole digger attached to a power tiller.

(c) Hexagonal steel-shaft: Designed augers were fitted with the bottom of hexagonal steel-shaft by steel ring and pin. The power is transmitted to the hexagonal shaft by two gears. The hexagonal shaft was fitted with second gear with hexagonal ring. The hexagonal shaft is 42 mm diameter and 800 mm total length.

(d) Depth-gauge (adjusting) mechanism: The mechanism consists of three parts: (a) Gear with 21 teeth, 66 mm diameter and 33 mm thickness, (b) The rack with length of 870 mm, width of 32 mm and number of teeth 83 and (c)

Manual wheel with 250 mm diameter rotated by welded handle with length of 125 mm.

(e) Augers (Fig. 2): Three augers with diameters of 150, 200 and 250 mm were constructed and tested. The total length of auger was 625 mm. The auger pitch " p_t" affects the penetration and cutting into soil. Too small or too large pitch will make it more difficult to penetrate soil. In fact, the penetration angle "α" can be calculated and is shown in table 2 as follows:

$$\alpha = \tan^{-1} \left(\frac{p_t}{2 d} \right)$$

Where "α" increased from the outer edge of auger helix to the inside of its flute. Moreover the optimum penetration angle depends on soil type and compaction.

Table 2: The relation between auger diameter, auger pitch and penetration angle of auger.

| Auger diameter, cm. | 15 | | | 20 | | | 25 | | |
|---------------------|----|----|----|----|----|----|----|----|----|
| Auger pitch, cm. | 10 | 15 | 20 | 10 | 15 | 20 | 10 | 15 | 20 |
| Penetration angle. | 18 | 30 | 34 | 14 | 20 | 30 | 11 | 17 | 22 |

The steel type of the auger knife was "Bohler K100 or DIN 1.2080 X210Cr12". The chemical composition of steel knife is shown in table 3.

Table 3: The chemical composition of steel knife of auger (Bohler company – 2006).

| The elements, %. | | | | | |
|------------------|------|------|-------|------|------|
| C | Si | Mn | Cr | Ni | W |
| 1.98 | 0.19 | 0.32 | 11.84 | 0.18 | 0.05 |

The hardness of the knife steel is up to 63 – 65 HRC at temperature of 940 to 970 °C.

(3) Power tiller: The designed hole digger was operated by a power tiller. The specifications of the power tiller were as follows:

Model: Grillo 131, Italian made, power: 10 kW (13.6 hp), speed: 5 forward speeds (1.2 – 4.2 km / h) and 2 reverse speeds (0.8 – 1.7 km/h) and power take-off (PTO) speed: 1028 rpm.

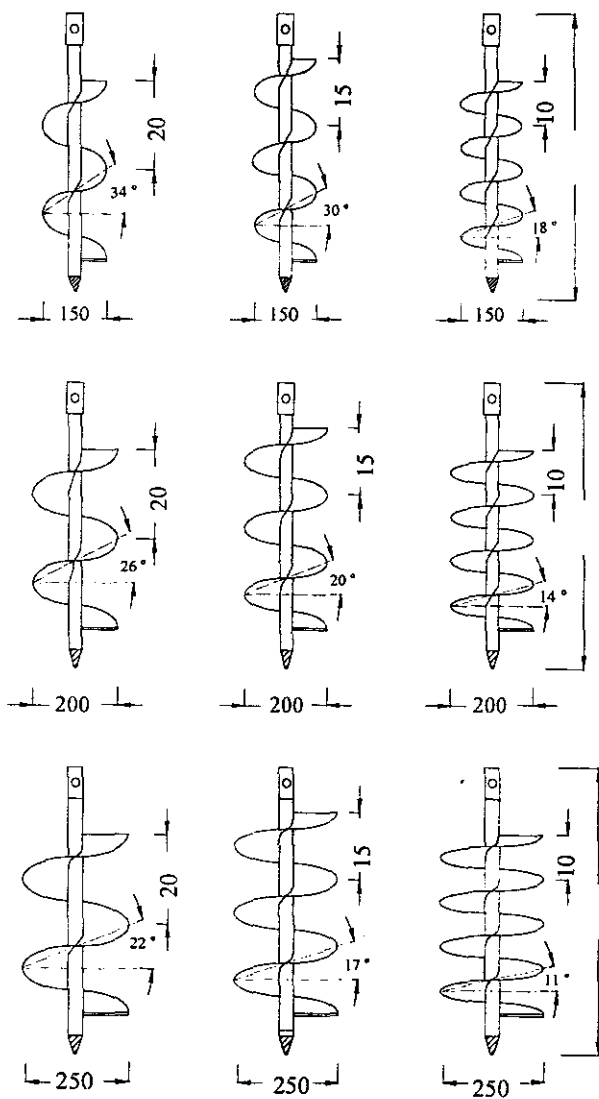

Fig. 2: The designed three augers of different pitches 100, 150 and 200 mm.

(4) Instrumentations:

(a) Penetrometer resistance measurements: Soil penetration can be measured by a cone penetrometer. A cone penetrometer was specified by A S A Ξ S 313 – 1 as cited by Agricultural Engineers as 30 circular stainless steel cone with driving shaft. The cone index has been defined as the force per unit depth of penetration according to the following equation: $R = F/A$

Where : $R =$ Specific soil penetration, $F =$ Required force, and $A =$ Projected area of penetrometer. The push type penetrometer was used to determine penetrometer resistance of the soil profile before digging operations.

(b) Speedometer: A speedometer was used to measure the auger speed with the three ranges available: 1st range 5 -50 m/min (50 – 500 rpm) direct reading. 2nd range 50 – 500 m/min (500 – 5000 rpm) scale value rpm \times 10. 3rd range: 500 – 5000 m/min (5000 – 50000 rpm) scale value rpm \times 100.

2-3: Methods:

2-3-1: Measurements:

(1) Fuel consumption and power requirement: Fuel consumption was determined by measuring the required fuel to refill the fuel tank after the treatment period. Consumed energy per feddan was calculated through measuring fuel consumption for each of treatment operating speed. The power tiller was instrumented to measure run time and fuel consumption. The consumed energy was calculated by using the following formula:

$$P = 3.23 F_c \text{ cited by Hunt, 1983.}$$

Where: $P =$ Power requirements (kW),

$F_c =$ The fuel consumption (L/h.).

(2) Digging efficiency: The percentage volume of the soil resulted from the digging was estimated by measuring the height (H_1) and the width (L) of heaped soil round the hole (Fig. 3). Where: $L = R_1 - R_0$ cm. All measurements were carried out at three angular speeds of 75, 100 and 150 rpm, three auger-diameters of 15, 20 and 25 cm and three hole-depths of 20, 30 and 40 cm. To achieve the highest digging efficiency and shape uniformity of the hole, R_1 had to be $\leq 3-3.5 R_0$ (Scripnic, 1968). Moreover, volume of the soil resulted from digging must be equal to hole volume multiplied by the swelling factor of soil.

$$H_1 = \frac{K_a H_0 (R_0)^2}{R_g (R_1 - R_0)}$$

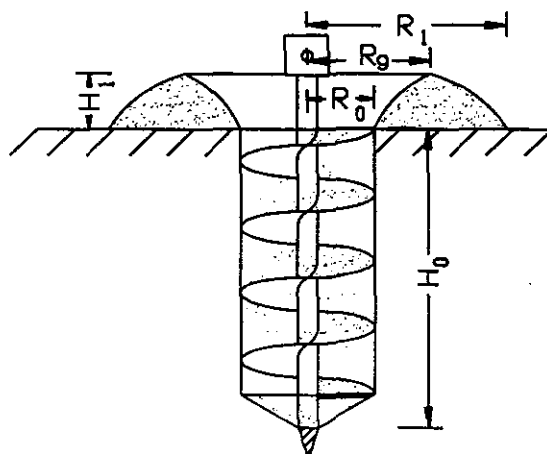

Fig. 3: Hole dimensions.

Where: R_0 : Radius of the hole, cm, R_1 : Radius from the end of the accumulated soil, cm, R_g : Radius from the center to the middle of the accumulated soil, cm, H_1 : The height of the soil resulting from digging, cm, H_0 : Hole depth, cm, and K_a : swelling factor. Swelling factor (K_a) was calculated for clay soil (1.75).

The digging efficiency was calculated by using the following formula:

$$\eta_d = \frac{V_{res.}}{V_{total}} \times 100$$

Where: η_d = Efficiency of the digging, $V_{res.}$ = Volume of the soil resulted from the digging (soil outside the hole), $V_{total.}$ = Volume of the total soil inside and outside the hole.

(3) **Hole productivity:** Hole productivity was calculated by measuring the total time of digging one hole. Production of holes per hour was then calculated. The variables affecting the hole productivity (table 4) were combined into dimensionless groups according to (Khurmi, 1978 and Awady, 1995).

Table 4: The variables affecting the hole productivity.

| No. | Variables | Symbol | Dimension |
|-----|---------------------------------|--------|-------------------|
| 1 | Hole productivity. | P_r | 1/s |
| 2 | Auger speed. | V_a | L/T |
| 3 | Forward speed. | V_f | L/T |
| 4 | Auger diameter (Hole diameter). | d_a | L |
| 5 | Hole depth. | d_h | L |
| 6 | Auger pitch. | p_t | L |
| 7 | Penetration resistance. | P | M/LT ² |
| 8 | Density of soil. | ρ | M/L ³ |
| 9 | Moisture content of soil. | Φ | % |

(M, L, T are principals of mass, length, and time resp.)

The resulting dimensionless functional relation is:

$$P_r p_t / V_f = f (V_a / V_f, d_a / p_t, d_h / p_t, P / \rho V_f^2, \Phi)$$

$$P_r = V_f / p_t f (V_a / V_f, d_a / p_t, d_h / p_t, P / \rho V_f^2, \Phi)$$

(4) **Cost:** The operation costs of the designed hole digger attached to a power tiller calculated according to equation of Awady, 1978 in the following form:

$$C = \frac{P}{h} \left(\frac{1}{a} + \frac{i}{2} + t + r \right) + (1.2 \text{ w.s.f}) + \frac{m}{144}$$

Where: C = Hourly cost, P = Price of the machine and power tiller, h = Yearly working hours, a = Life expectancy of the machine in years, i = Interest rate/year, t = Taxes rate, r = Repairs and maintenance ratio, w = Power of the machine kW, s = Specific fuel consumption L/kW.h, f = Fuel price L.E./L, m = Monthly wage ratio, 1.2 = Factor accounting for ratio of rated power and lubrications, 144 = The monthly average working hours.

Table 5: The constants used in Awady equation:

| P, L.E. | h, h/year | a, year | i, % | t, % | r, % | w, kW | s, L/kW.h** | f, L.E/L | m, L.E/mont h |
|---------|-----------|---------|------|------|------|-------|-------------|----------|---------------|
| 21000 | 1000 | 10 | 7 | 5 | 6 | 10 | 0.36 | 0.9 | 1000 |

* P = price of a hole digger + power tiller = 3000 + 18000

** Measured specific fuel consumption.

$$\text{Cost of digging one holes} = \frac{\text{Hourly cost, LE}}{\text{Holes production per hour}}$$

RESULTS AND DISCUSSION

1: Penetration resistance.

Fig. 4 shows the penetration resistance for clay soil at different moisture content and different soil depths. The maximum penetration resistance was 69.8 N/ cm² at 18 % moisture content and soil depth 40 cm. Whereas, the minimum penetration resistance was 24.9 N/ cm² at 26 % moisture content and soil depth 20 cm.

2: Effect of auger speed, auger diameter, auger pitch (penetration angle), moisture content and hole depth on hole-digging production rate for clay soil.

Fig. 5 shows the effect of auger speed, auger diameter, auger pitch, moisture content and hole depth on hole-digging production rate for clay soil. The hole digging productivity of the developed machine increased with increasing auger speed, and decreased by increasing auger diameter and auger pitch and angle and hole depth. The maximum hole productivity of 324 hole/h was obtained with auger speed of 150 rpm, hole diameter 15 cm, hole depth 20 cm, auger pitch 20 cm at moisture content 26 %. Whereas, the minimum hole productivity of 54 hole/h was obtained with auger speed of 75 rpm, hole diameter 25 cm, hole depth 40 cm and auger pitch 10 cm at moisture content 18%.

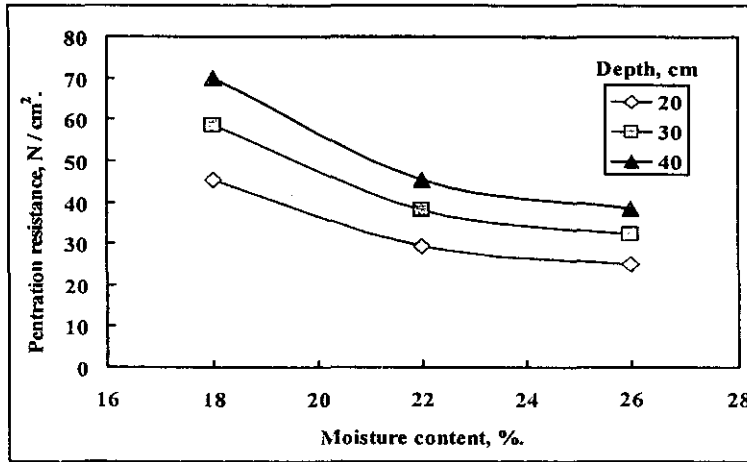

Fig. 4: Penetration resistance for clay soil at different moisture-contents and soil-depths.

The increasing of a hole-digging production by increasing auger speed is due to decreasing of soil penetration time and time of soil mass moved from the hole by using a high speed of auger.

The variables affecting the hole productivity were combined into dimensionless groups. The general equation of the hole productivity was formulated to follow:

$$P_r = \frac{V_f^{0.76} V_a^{0.16} \rho_t^{0.3} P^{0.04} \Phi^{1.7}}{5.4 d_a^{0.58} d_h^{0.72} \rho^{0.04}}$$

Where: P_r = Hole productivity,

V_a = Auger speed, m/s, (ranged between 0.58, , and 1.96 m/s),

V_f = Average forward speed, m/s (ranged between 0.49, , and 0.86m/s)

d_a = Auger diameter, m, (ranged between 0.15 – 0.25 m),

d_h = Hole depth, m, (ranged between 0.2 – 0.4 m),

P = Penetration resistance, kg/m², (ranged between 45200 – 69800 kg/m²),

ρ = Bulk density of soil, kg / m³ (ranged between 1050 – 1200 kg / m³),

ρ_t = Auger pitch, m (ranged between 0.1 – 0.2 m), and

Φ = Moisture content of soil, (ranged between 18 – 26%).

Fig. 6 shows the regression equation between measured and calculated productivity. The following equation expresses the relation :

$$Pr (\text{Mes.}) = 0.942 Pr (\text{Cal.}) + 0.0013, R^2 = 0.89.$$

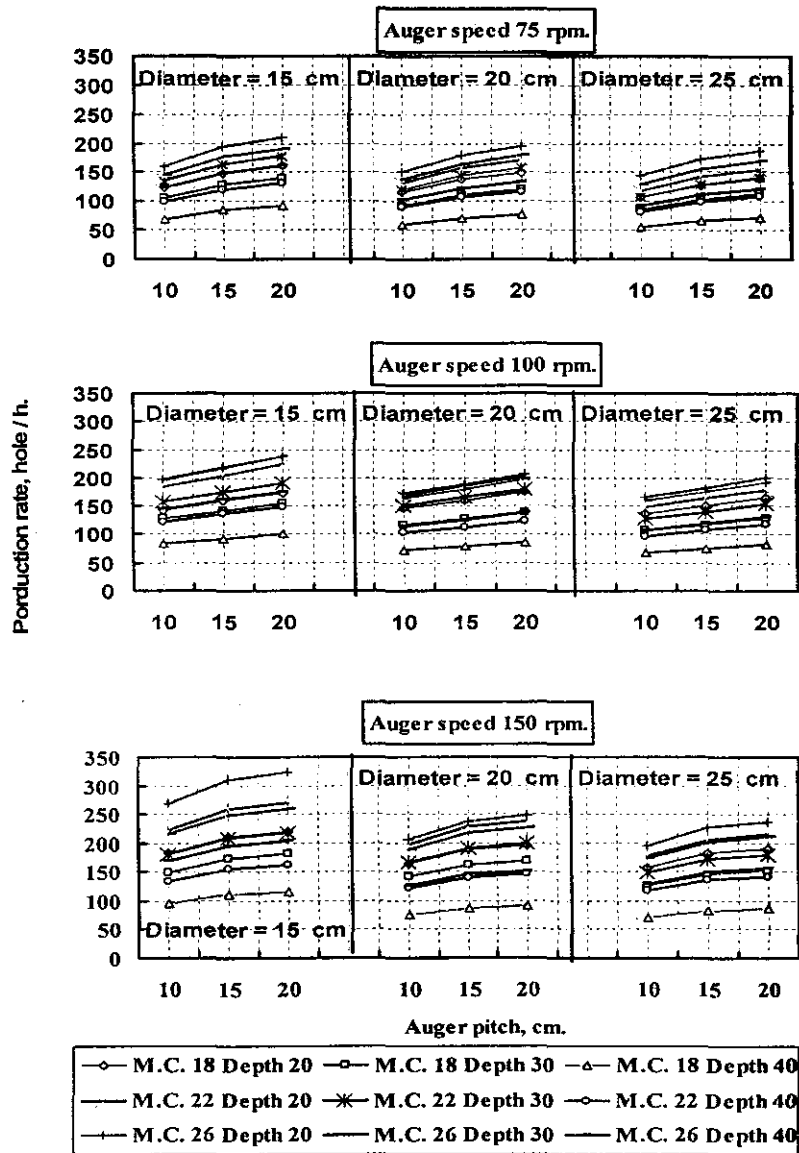

Fig. 5: Effect of auger speed, auger diameter, auger pitch, moisture content (%) and hole depth on hole-digging production rate for clay soil.

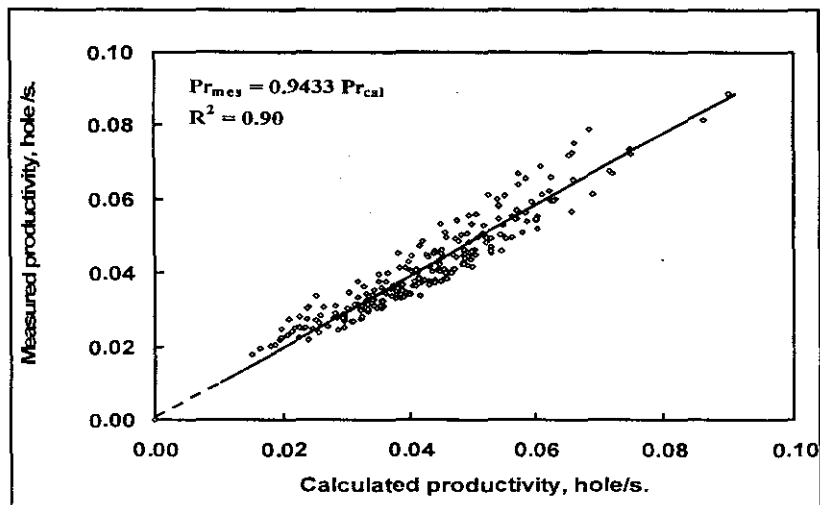

Fig. 6: The relationship between measured (Pr_{mes}) and calculated (Pr_{cal}) hole-digging productivities.

3: The effect of different working parameters on digging efficiency.

Fig. 7 shows the effect of auger speed, auger diameter, auger pitch, moisture content and hole depth on digging efficiency. The digging efficiency increased by increasing auger speed, auger diameter, hole depth and moisture content of soil. The increasing of digging efficiency is due to increasing the mass of digging soil. The increasing of digging efficiency by increasing soil moisture-content is due to decreasing soil stability.

The maximum of digging efficiency was 91 % at auger speed 150 rpm, auger diameter 25 cm, auger pitch 20 cm, hole depth 40 cm and moisture content 26%. Whereas, the minimum digging efficiency was 48 % at auger speed 75 rpm, auger diameter 15 cm, auger pitch 10 cm, hole depth 20 cm and moisture content 18 %.

4: The effect of different working parameters on fuel consumption.

Fig. 8 shows the effect of auger speed, auger diameter, auger pitch, moisture content and hole depth on fuel consumption. The fuel consumption of the designed machine increased with increasing auger diameter, auger speed, hole depth, and soil resistance. The maximum fuel consumption was 0.69 L/h was obtained with auger speed of 150 rpm, hole diameter 25 cm, hole depth 40 cm, auger pitch 10 cm and moisture content 18 %.. Whereas, the minimum fuel consumption of 0.41 L/h was obtained with auger speed of 75 rpm, hole diameter 15 cm, hole depth 20 cm, auger pitch 20 cm and moisture content 26 %. The increasing of fuel consumption by decreasing soil moisture-content and auger angle or pitch is due to increasing penetration soil-resistance.

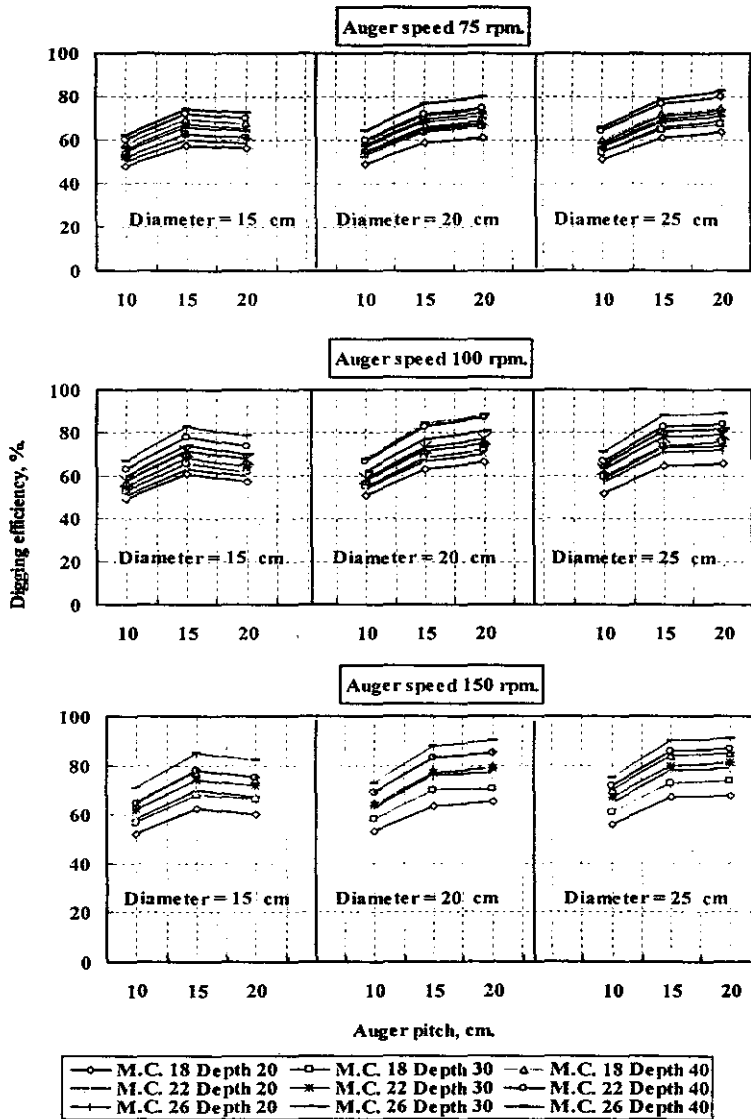

Fig. 7: Effect of auger speed, auger diameter, auger pitch, moisture content (%) and hole depth on digging efficiency for clay soil.

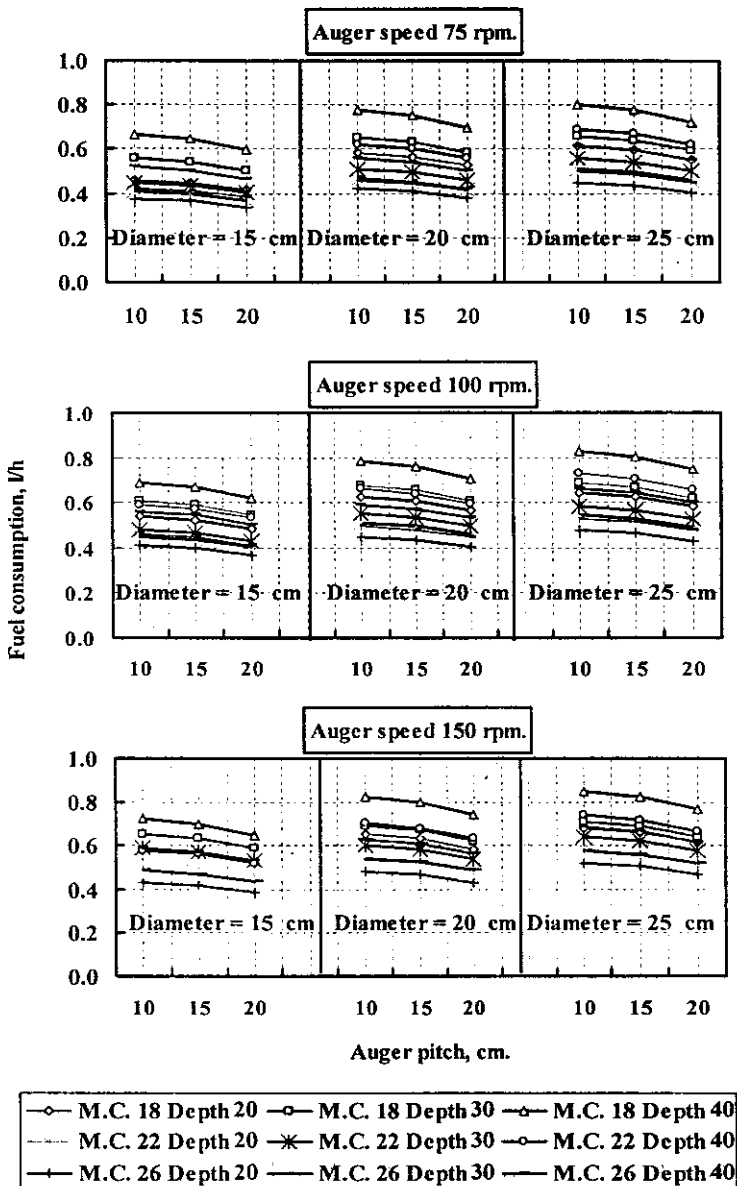

Fig. 8: Effect of auger speed, auger diameter, auger pitch, moisture content (%) and hole depth on fuel consumption of digging the clay soil.

5: The effect of different working parameters on power requirements

Fig. 9 shows the effect of auger speed, auger diameter, auger pitch, moisture content and hole depth on power requirements. The power requirements of the designed machine increased with increasing auger diameter, auger speed, hole depth and soil resistance. The maximum power requirements was 2.72 kW was obtained with auger speed of 150 rpm, hole diameter 25 cm, hole depth 40 cm, auger pitch 10 cm and moisture content 18 %. Meanwhile the minimum power requirements of 1.08 kW was obtained with auger speed of 75 rpm, hole diameter 15 cm, hole depth 20 cm, auger pitch 20 cm and moisture content 26 %. The increasing of power requirement by decreasing soil moisture-content and auger angle or pitch is due to increasing penetration soil-resistance.

6: Cost of using the modified hole digger.

Table 6 shows the effect of auger diameter, auger pitch, hole depth, and soil moisture-content on operation cost of hole digger speed of 150 rpm in clay soil. The operation cost increased by increasing auger diameter, hole depth and soil penetration resistance at different parameters. The minimum operation cost was 0.05 L.E./hole at auger diameter 15 cm, auger pitch 15 cm, hole depth 20 cm and soil moisture-content 26 %. Whereas, the maximum operation cost was 0.23 L.E./hole at auger diameter 25 cm, auger pitch 10 cm, hole depth 40 cm and soil moisture-content 18 %.

Table 7 shows the hole productivity and operation cost for one hole by using manual digging at auger pitch of 15 cm, moisture content of 26 % and different hole-depths and auger-diameters. The operation cost by using a hole digger attached to a power tiller decreased by about 500 - 950 % compared with manual digging.

Table 6: Cost of using a developed hole-digger at auger speed of 150 rpm and different soil moisture-contents, hole-depths and auger-diameters and pithes.

| Moisture content of soil, %. | Hole depth, cm. | Cost, L.E./hole. | | | | | | | | |
|------------------------------|-----------------|---------------------|------|------|------------------|------|------|------------------|------|------|
| | | Auger diameter, cm. | | | | | | | | |
| | | 15 | | | 20 | | | 25 | | |
| | | Auger pitch, cm. | | | Auger pitch, cm. | | | Auger pitch, cm. | | |
| | | 10 | 15 | 20 | 10 | 15 | 20 | 10 | 15 | 20 |
| 18 | 20 | 0.09 | 0.08 | 0.07 | 0.10 | 0.09 | 0.08 | 0.10 | 0.09 | 0.09 |
| | 30 | 0.11 | 0.09 | 0.09 | 0.11 | 0.10 | 0.10 | 0.13 | 0.11 | 0.11 |
| | 40 | 0.17 | 0.15 | 0.14 | 0.21 | 0.18 | 0.18 | 0.23 | 0.20 | 0.19 |
| 22 | 20 | 0.07 | 0.06 | 0.06 | 0.08 | 0.07 | 0.07 | 0.09 | 0.08 | 0.08 |
| | 30 | 0.09 | 0.08 | 0.07 | 0.10 | 0.08 | 0.08 | 0.11 | 0.09 | 0.09 |
| | 40 | 0.12 | 0.10 | 0.10 | 0.13 | 0.12 | 0.11 | 0.14 | 0.12 | 0.11 |
| 26 | 20 | 0.06 | 0.05 | 0.05 | 0.08 | 0.07 | 0.07 | 0.08 | 0.07 | 0.07 |
| | 30 | 0.07 | 0.06 | 0.06 | 0.09 | 0.07 | 0.07 | 0.09 | 0.08 | 0.08 |
| | 40 | 0.09 | 0.08 | 0.08 | 0.13 | 0.11 | 0.11 | 0.13 | 0.11 | 0.10 |

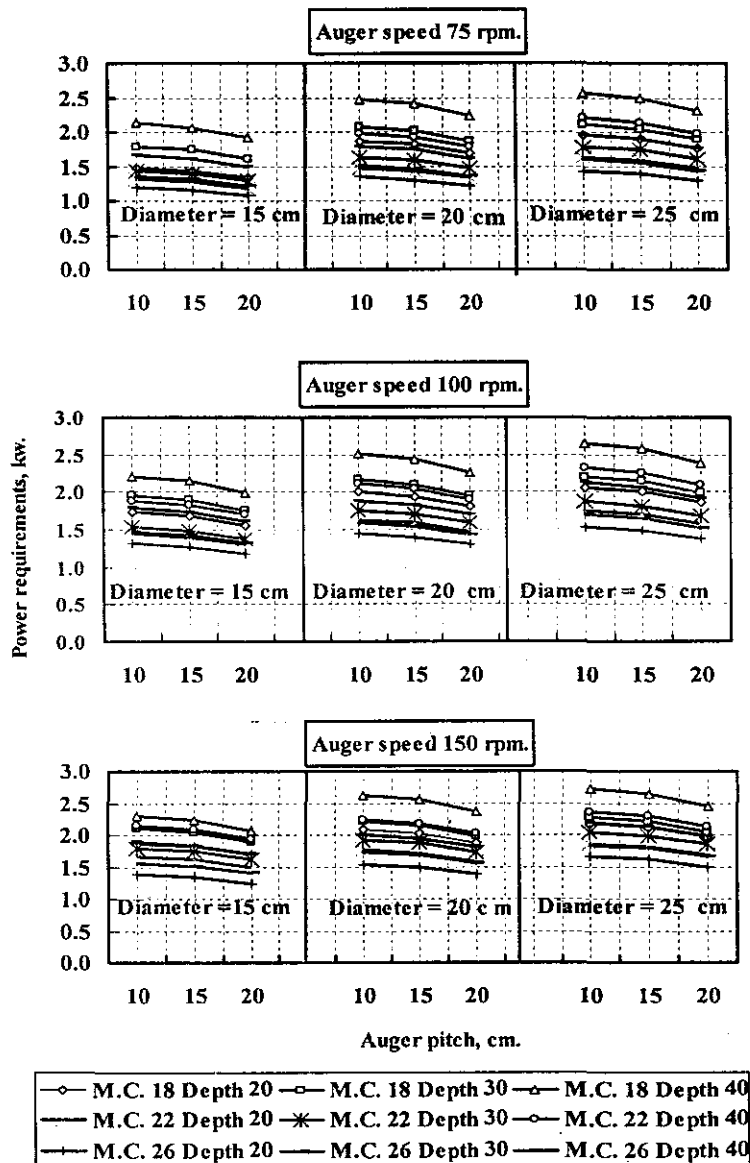

Fig. 9: Effect of auger speed, auger diameter, auger pitch, moisture content (%) and hole depth on fuel power requirement of digging the clay soil.

Table 7: Productivity and operation cost for one hole by using manual digging by using auger pitch of 15 cm at moisture content of 26 % and different hole-depths and auger-diameters.

| Hole depth | Auger diameter, cm. | | | | | |
|------------|---------------------|----------------|-------------|----------------|-------------|----------------|
| | 15 | | 20 | | 25 | |
| | Hole / day. | Cost, LE./hole | Hole / day. | Cost, LE./hole | Hole / day. | Cost, LE./hole |
| 20 | 120 | 0.25 | 90 | 0.30 | 60 | 0.50 |
| 30 | 80 | 0.38 | 60 | 0.50 | 40 | 0.75 |
| 40 | 60 | 0.50 | 45 | 0.66 | 30 | 0.88 |

Conclusions.

The results can be summarized as follows:

- The maximum hole productivity of 324 hole/h was obtained with auger speed of 150 rpm, hole diameter 15 cm, hole depth 20 cm, auger pitch 20 cm at moisture content 26%. Whereas, the minimum hole productivity of 54 hole/h was obtained with auger speed of 75 rpm, hole diameter 25 cm, hole depth 40 cm and auger pitch 10 cm at moisture content 18%.
- The maximum fuel consumption was 0.69 L/h was obtained with auger speed of 150 rpm, hole diameter 25 cm, hole depth 40 cm, and auger pitch 10 cm.
- The maximum power requirements was 2.72 kW was obtained with auger speed of 150 rpm, hole diameter 25 cm, hole depth 40 cm, auger pitch 10 cm and moisture content 18 %.
- The operation costs by using a hole digger attached to a power tiller decreased by about 500 - 950 % compared with manual digging.

REFERENCES

Awady, M. N., 1978, Engineering of tractors and agricultural machinery, Text Bk., col. Ag., Ain-shams U., 5th Ed. : 164-167. (In Arabic.) (Updating 1998).

Awady, M. N., 1995, Computer and data analysis, Text memos, Col. Ag., Ain Shams U.: 30 – 35.

Barger, E. L., Liljedahl, W., Carleton, M. and Mckibben, E. G., 1963, Tractors and their power unit, Wiley Eastern Private Ltd., New Delhi, 2th Ed. 229 – 236.

Chaaban, M. A., El Awady, M. N., Yehia, I., and Khalil, S. K. 2007, Factors affecting the design of a hole digger attached to a power tiller, environmental, J. Environ. Sci., Vol. 15, No. 1: 83 - 111.

El-Shal, M. S., 1993, A study on some parameters affecting post-hole digger efficiency, Misr J. Agri. Eng., 10 (4): 888 – 899.

Hunt, R. D., 1983, Farm power and machinery management, Iowa State Univ. Press Ames, 8th Ed. 28 – 29.

Kapnehko, A. H., E-Heb, A. A. and XA-Ahck, B. M., 1976, Farm Machinery (in Russian), Hbl., Book, Moscow: 432-434.

Khalil, S. K., 2008, Development and design of a hole digger to minimize required energy for operation and side effect on agricultural soil, Ph. D., Inst. Environ. Studies and Res., Ain Shams U.: 20 - 41.

Khurmi, R. S., 1978, A text book of hydraulics and fluid mechanics, Chand and Co. LTD, New Delhi: 787 – 807.

Purtskhvanidze, M., Keller, N., 1990, Hole digger for slopes, Farm Mechanization (in Russian), No. 3: 38.

Scripnic, V., and Babicin, P., 1968, MASTAGRICOLE, (Book), Romania: 170-191.

العوامل المؤثرة على أداء حفار جور مطور إبراهيم يحيى، محمد حسن قابيل و خليل سيد خليل معهد بحوث الهندسة الزراعية.

يهدف هذا البحث إلى دراسة بعض العوامل المؤثرة على تطوير حفار جور مثل خطوة وزاوية اختراق وسرعة وقطر وعمق البريمة ونسبة رطوبة التربة وتجميع هذه العوامل في علاقة رياضية تنبؤية، وكان ملخص النتائج التي تم الحصول عليها كالتالي:

- أن أعلى إنتاجية لحفار الجور كانت ٣٢٤ حفرة / ساعة عند ظروف تشغيل ١٥٠ لفة / دقيقة و قطر البريمة ١٥ سم و عمق الحفر ٢٠ سم وخطوة البريمة ٢٠ سم وذلك عند محتوى رطوبى للتربة ٢٦ % .
- مقاومة التربة المستخدمة عند محتوى رطوبى ١٨ % تزيد بنسبة ٣٥ و ٤٥ % مقارنة بالتربة المستخدمة عند محتوى رطوبى ٢٢ % و ٢٦ % على الترتيب.

- تم تجميع العوامل المؤثرة على معدل زمن حفر الجورة في مجموعات عديمة الوحدات . وقد تم إيجاد علاقة رياضية تربط بين هذه المجموعات عديمة الوحدات وهى:

$$P_r = \frac{V_f^{0.76} V_a^{0.16} p_t^{0.3} \rho^{0.04} \Phi^{1.7}}{5.4 d_a^{0.58} d_h^{0.72} \rho^{0.04}}$$

حيث: P_r = إنتاجية الحفر،

V_a = سرعة البريمة، (تتراوح بين ٠,٥٨ - ١,٩٦ متر/ثانية)،

V_f = السعة الأمامية للألة (تتراوح بين ٠,٤٩ - ٠,٨٦ متر/ثانية)،

d_a = قطر البريمة، (تتراوح بين ٠,١٥ - ٠,٢٥ متر)،

d_h = عمق الحفر، (تتراوح بين ٠,٢ - ٠,٤ متر)،

P = مقاومة اختراق التربة، (تتراوح بين ٤٥٢٠٠ - ٦٩٨٠٠ كجم/متر^٢)،

ρ = الكثافة الظاهرية للتربة، (تتراوح بين ١٠٥٠ - ١٢٠٠ كجم/متر^٣)،

p_t = خطوة البريمة، (تتراوح بين ٠,١ - ٠,٢ متر)،

Φ = المحتوى الرطوبى للتربة، (تتراوح بين ١٨ - ٢٦ %).

- كانت أكبر كمية وقود مستهلكة ٠,٦٩ لتر/ساعة وذلك عند ظروف تشغيل ١٥٠ لفة / دقيقة و قطر البريمة ٢٥ سم وعمق الحفر ٤٠ سم وخطوة البريمة ١٠ سم وذلك عند محتوى رطوبى للتربة ١٨ %.

- كانت أعلى قدرة مطلوبة في عمليات التشغيل للأرض الطينية ٢,٧٢ كيلوات وذلك عند ظروف تشغيل ١٥٠ لفة / دقيقة و قطر البريمة ٢٥ سم وعمق الحفر ٤٠ سم وخطوة البريمة ١٠ سم وذلك عند محتوى رطوبى للتربة ١٨ %.

- أدنى تكاليف كانت ٠,٠٥ جنية / جورة وذلك عند قطر بريمة ١٥ سم، وخطوة بريمة ١٥ سم، وعمق حفر ٢٠ سم، ونسبة رطوبة تربة ٢٦ % . بينما كان أقصى تكاليف ٠,٢٣ جنية / جورة عند قطر بريمة ٢٥ سم، وخطوة بريمة ١٠ سم، وعمق حفر ٤٠ سم، ونسبة رطوبة تربة ١٨ % . و استخدام حفار الجور المعلق على جرار صغير ذى عجلتين يوفر التكاليف بنسبة حوالى ٥٠٠ - ٩٥٠ % مقارنة بعمليات الحفر اليدوية.