

A STUDY ON AGRICULTURAL TRACTORS STEERING MECHANISM

2- The turning radius 3- Deviation of the turning center (DTC)

*Sarhan, A. M. M. **Al – Katary, H. S. ***El- Awady, M. N.

ABSTRACT

The main aim of this research was to increase the operation efficiency of agricultural tractor to suit the conditions and potentials of the Egyptian farmer. This leads to increase the rates of the feddan production and raise the value of the yield per feddan. This meets the requirement to achieve the strategic goals of the agricultural development by modifying and developing the modern technology, especially the agricultural tractors to suit the local environment in all agricultural operations, including plowing. Laboratory experiments and statistical analysis for the data of the research were run and hydraulically steering was designed by suing a closed hydraulic circuit for the tractor. The main results obtained from the experiments are summarized in the following main points:

- 1-Mathematicl equations are derived to find the turning radii by knowing the hydraulic cylinder length, the constant tractor dimensions at different geometric proportions.*
- 2-Minimum values of the turning radius steering. 3-Decreasing the costs maintaining the tractor by decreasing the costs maintaining of tractor steering equipments. 4-The modification suits all the agricultural operations even for small holdings in Egypt.*

INTRODUCTION

The aim of this research is necessary to increase the rates of production and raise the yield per feddan, as goals for agricultural development. This can be done by developing the agricultural tractors to suit the local environment and the small agricultural holdings dominant in Egypt. This study aims to develop steering in particular. It aims to design a mechanism which can be controlled hydraulically to work on the front land-wheels.

*Ph. D. Stud. Dept. Eng., Fac. Agric., Al-Azhar Univ. Cairo Egypt.

**Prof., Agric. Eng. Dept., Fac. Agric., Al-Azhar Univ. Cairo Egypt .

***Emt. Prof., Agric. Eng. Dept., Fac. Agric., Ain Shams Univ.

Grovum and Zoerb (1970) assumed the turning radius (R_1) (see the accompanying Fig. [1]). since δ_1 and ϕ are compliments of equal angles, it also follows that:

$$\phi = \delta_1 \quad \text{Also,} \quad \frac{WB}{R_1} = \tan \delta_1 \quad \text{or} \quad R_1 = \frac{WB}{\tan \phi}$$

Where:WB: is the tractor wheelbase.

Shukla et al. (1970) stated that an optimum sensor length was found for each type of steering and the optimum length was relatively independent of the type of path, are shown in Fig. (1).

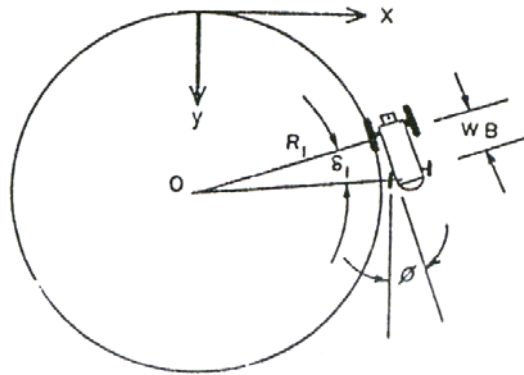

Fig. (1): Motion resulting from a constant steering-wheel displacement, Grovum and Zoerb (1970).

Whitaker (1976) indicated that the toe-out, Fig. (2), characteristic causes the radii of all four wheels to meet at an approximate common center during a turn. For any turn angle of the outer wheel, the correct angle for the inner wheel may be found graphically as shown in Fig. (2), or by the

following equation:
$$\text{Cot } B = \text{Cot } A - \frac{TW}{WB}$$

Where:

A= the outer turn angle. **B**=the inner turn angle. **TW**= the tread-width. **B**= the wheelbase.

This equation may be used repeatedly for many pairs of turn angles (**A** and **B**)

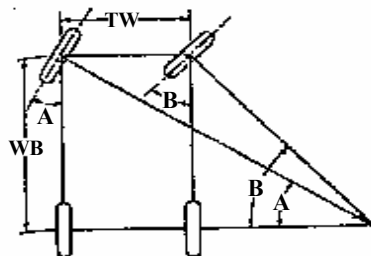

Fig. (2): Front wheel toe-out during a turn, Whitaker (1976).

Smith et al. (1985) concluded that the “constant-turn” geometry techniques are useable for machine guidance; however, the resulting algorithms must be tested under real-world dynamic conditions to verify their adequacy. Using a computer program based on mathematical analysis for the coplanar linkage, deviations from the ideal Ackermann geometry were plotted, as shown in Fig.(3).

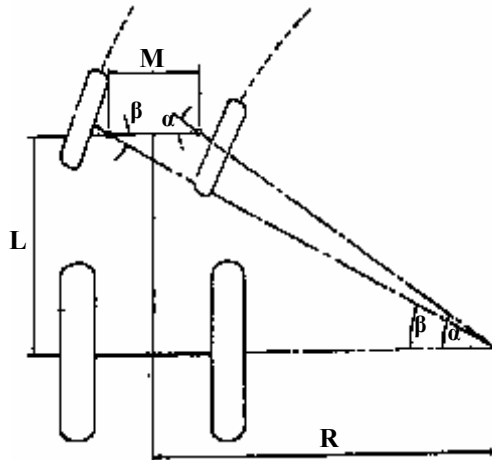

Fig. (3): Schematic of Ideal Ackermann geometry,(Zhanng, 1985).

Zhang (1985). This relationship is expressed by the following equation:

$$\text{Cot}\beta - \text{Cot}\alpha = M / L$$

Where:

β =outside steering angle. α =inside steering angle. M =distance between the two points of kingpin's extension on the ground. L =wheelbase.

Smith et al. (1987) concluded that the analysis of steering geometry and machine motion using the concepts embodied in constant-turn geometry was adequate for defining the system of geometric relationships (algorithm) needed to guide agricultural machines.

Zhang et al. (1988a) found that mathematical relationships between inside and outside steering angles developed for coplanar and independent steering linkages can be used to optimize the design of steering linkage system.

Zhang et al. (1988b) said that using steering systems can not comply with ideal Ackermann geometry even with those optimum designed ones. A new type of steering system to improve steering performance is needed.

Steering mechanism, called CCS (the common- Center-Steering) steering system, has been developed, which is able to satisfy the Ackermann geometry at any angle within the steering range. The features of the CCS steering box make are suitable for trucks and vans.

Kwang Waropas (1994) indicated that the mower is steering using the steering mechanism in conjunction with the wheel clutch–brake mechanism. The transmission is similar to that of the locally made 2 wheeled tractor .The minimum turning radius was 2.7m.

MATERIAL AND METHODS

A- Tractor:

The Belarus tractor, **65B.HP (48.2kw)** was common and widespread under Egyptian conditions. The tractor is multi purpose of the model **10M3-6KM**. It was used in this research. The tractor was tested in plowing operation. After modification it was tested at agricultural tractors and machinery research laboratory, Agricultural Engineering Department, Faculty of Agriculture, Al-Azhar University.

A-1: The tractor before modification: 1-Gasoline engine (65 HP, 48.2kw) at 1750 rpm. 2- Wheels (four wheels). 3-Minimum turning radius = 5m.

4- Steering system:

(A): The components: It consists of: (1):Front axle; (2):Steering wheel to track width adjustment mechanism, determining the front wheel toe-in and checking toe-in of steering wheels; (3):Sector, spool, bushing, steering gear case, rack and oil drain pipeline (Fig.4); (4): Steering column, shock absorbers, sleeve, steering wheel shaft and steering wheel; (5): Steering gear, steering arm, steering shaft and worm gear; (6): Hydraulic steering servo, housing, spring washer and front cover; (7): Mounted at the middle position on the tractor.

(B): The disadvantages of power steering: 1- Difficult to repair and maintain. 2- Costs of repair and maintenance. 3-The spare parts price is expensive. 4- Complex construction. 5- Mechanical steering system with addition to hydraulic steering servo.

A-2: The tractor after modification: The tractor was modified to overcome the problems encountered during the experimentation. The

specifications of the tractor after modification are the same of tractor before modification but the different are follows:

Apparatus of power hydraulic steering system :

It was power hydraulic steering circuit, Figs (5 and 6):

The components: It consists of: 1- Reservoir (Transmission housing); 2- Filter on intake; 2B-Filter on delivery; 3- Hydraulic pump. It consists of: A-Suction port; R-Lube fillets; I): Bearings; 2):Seals; 3):Cover; 4):Key; 8):Bearing; 9):Bushes; 10):Pipe union; 11):Pump body; 12):Engine block; 13):Conductor pinion; 4-Rotary valve; 5, 9- Check valve; 6- Pressure relief valve; 7-Hydraulic steering control valve: It consists of: 1): Fixing screw; 2): Lower cap; 4):Spacer; 6):Stator; 7): Rotor; 8):Intermediate flange; 9):Non return valve; 10): Pressure limit valve; 14): Distributor; 15, 18):Anti-cavitations valve; 6):Distributor body; 17):Anti-shock valve; 19):Short circuit valve; 21):Grooved hub; 25):Upper cap. 8- Transfer pump/motor; 17-Sleeve; 18-Anti-shock valves (cylinder safety valves); 19-Anti-cavitations valves (Makeup valves); 22- Power cylinder: It consists of: 1):Cylinder; 2):Locking; 3): Bearing; 4):Gland; 5):“O” Ring; 6, 12, 13):Seal; 7): Wiper seal; 8):Gland locking; 9):Cylinder rod; 10):Retaining Ring; 11):Piston.

23- Ducts: A-Intake; B- Delivery; C-Return; D-Users on LH side of power cylinder; E-Users on RH side of power cylinder; F-Anti-shock valve discharge; G- Transmission oil cooler; R-Flow regulator; W-Steering wheel.

B-: Devices:

B-1: Surveying instruments:

Tape steel 20m, steel ruler 30cm and arrows were used for measuring and determining longitudinal dimensions. Pins were used for hitching the hydraulic dynamometer from both sides. Steel bolts and plastic threads were used for determining turning radius.

B-2: The models:

Models were made at the central workshops in the Ministry of Agriculture and Land Reclamation, to measure the turning radius. Models for the mechanisms were made of wooden bars, for the various geometrical dimensions. They generally conform to as small scale of 1:2. The model configurations had the variable dimensions shown in Table (1).

Table (1): The variable dimensions of the models.

Configuration No.	Dimensions in mm.					
	W	W/2 or W/3	TR	r	Cot ϕ - Cot θ	
1	960	W/2	480	912	192	0.39
2	1110		555	1050	222	0.45
3	1260		630	1200	252	0.51
4	1410		705	1340	282	0.58
5	1110	W/3 =370	1050	222	0.45	

Their dimensions consist of fixed dimensions (**Cot θ =W/WB, WB=2450, e=70mm, r/W=0.2, TR/W=0.95** and $\gamma_0=\pi/2=90^\circ$). The rest of dimensions are shown in (Fig.9).

A natural-size model was made of steel to Conform with the tractor modifications.

Where: WB=Wheel base, W=Steering pivots distance (1110mm), r = Steering arm length, TR=Tie-rod length, ϕ = Outer front wheel steering angle, θ = Inner front wheel steering angle, e=the distance between tie-rod and hydraulic cylinder base γ = Upright angle, equal ($\pi/2$).

C- Experimental procedures:

Turning radius was tested by measuring the average turning cycle of tractor under test. The turning radius of each cycle of the tractor was recorded to determine the turning radius by steel bolts, plastic threads, steel ruler and tape in fifteen replicates. The aim of this test was to determine the turning radius for piston, inner, and outer front wheels of the tractor under test at average speed at no traction loads over concrete traction surface (Fig. 7).

D-Using mathematical analysis for the common-center-steering systems of tractors:

Analytical program was derived for 4-bar mechanism (steering mechanism) referring to Figs. (7 through 9), based on the mechanism data: WB: wheel base (2450mm), W: Steering pivots distance (1110 mm), r: Steering arm length (222mm), θ_0 : Initial steering arm angle (8.29°), TR: Tie-rod length (105cm), θ : Inner front wheel steering angle, ϕ : Outer front wheel steering angle; I: Instantaneous center. Equations of the turning radius are given as shown in Figs (7 through 9) .

RESULTS AND DISCUSSION

The study was carried out to indicate effects of the hydraulic cylinder length and the tractor dimensions at different geometric proportions on the following factors:

A- The turning radius:

1- Effect of the hydraulic cylinder length on the turning radius:

Figs. (7 through 10), illustrate effect of the hydraulic cylinder length, the front wheels steering angles, the piston steering angles (α), constant dimensions of the tractor on the turning radii at different geometric proportions. The turning radii equations can be derived as follow:

(a): Perfect steering case:

$$R_i = R_o - W ; R_o = R_i + W ; R = W/2 + R_i ; R = R_o - W/2$$

(b): Actual steering case: with six methods:

A- The right direction (R.H.Steer):

B- The left direction (L.H.Steer):

$$1- \therefore R_o = \frac{(WB)r \cos \phi}{TR - \frac{w}{2} - L \cos \alpha}$$

$$\therefore R_i = \frac{(WB)r \cos \theta}{\frac{w}{2} - TR + L \cos \alpha}$$

$$2- \therefore R_o = \frac{(WB)r \cos \phi}{TR - \frac{W(wb)}{WB} - L \cos \alpha}$$

$$\therefore R_i = \frac{(WB)r \cos \theta}{\frac{W(wb)}{WB} - TR + L \cos \alpha}$$

$$3- \therefore R_o = \frac{(WB)\sqrt{r^2 - [TR - \frac{w}{2} - L \cos \alpha]^2}}{TR - \frac{w}{2} - L \cos \alpha}$$

$$\therefore R_i = \frac{(WB)\sqrt{r^2 - [\frac{w}{2} - TR + L \cos \alpha]^2}}{\frac{w}{2} - TR + L \cos \alpha}$$

$$4- \therefore R_o = \frac{(WB)\sqrt{r^2 - [TR - \frac{w}{2} - L \cos \alpha]^2}}{TR - \frac{W(wb)}{WB} - L \cos \alpha}$$

$$\therefore R_i = \frac{(WB)\sqrt{r^2 - [\frac{w}{2} - TR + L \cos \alpha]^2}}{\frac{W(wb)}{WB} - TR + L \cos \alpha}$$

$$5- \therefore R_o = \frac{(WB)\sqrt{r^2 - [TR - \frac{w}{2} - \sqrt{L^2 - Y^2}]^2}}{TR - \frac{W}{2} - \sqrt{L^2 - Y^2}}$$

$$\therefore R_i = \frac{(WB)\sqrt{r^2 - [\frac{w}{2} - TR + \sqrt{L^2 - Y^2}]^2}}{\frac{W}{2} - TR + \sqrt{L^2 - Y^2}}$$

$$6- \therefore R_o = \frac{(WB)\sqrt{r^2 - [TR - \frac{w}{2} - \sqrt{L^2 - Y^2}]^2}}{TR - \frac{W(wb)}{WB} - \sqrt{L^2 - Y^2}}$$

$$\therefore R_i = \frac{(WB)\sqrt{r^2 - [\frac{w}{2} - TR + \sqrt{L^2 - Y^2}]^2}}{\frac{W(wb)}{WB} - TR + \sqrt{L^2 - Y^2}}$$

Where: R_o : The outer turning radius in cm; R_i : The inner turning radius in cm; R : The turning radius in cm.

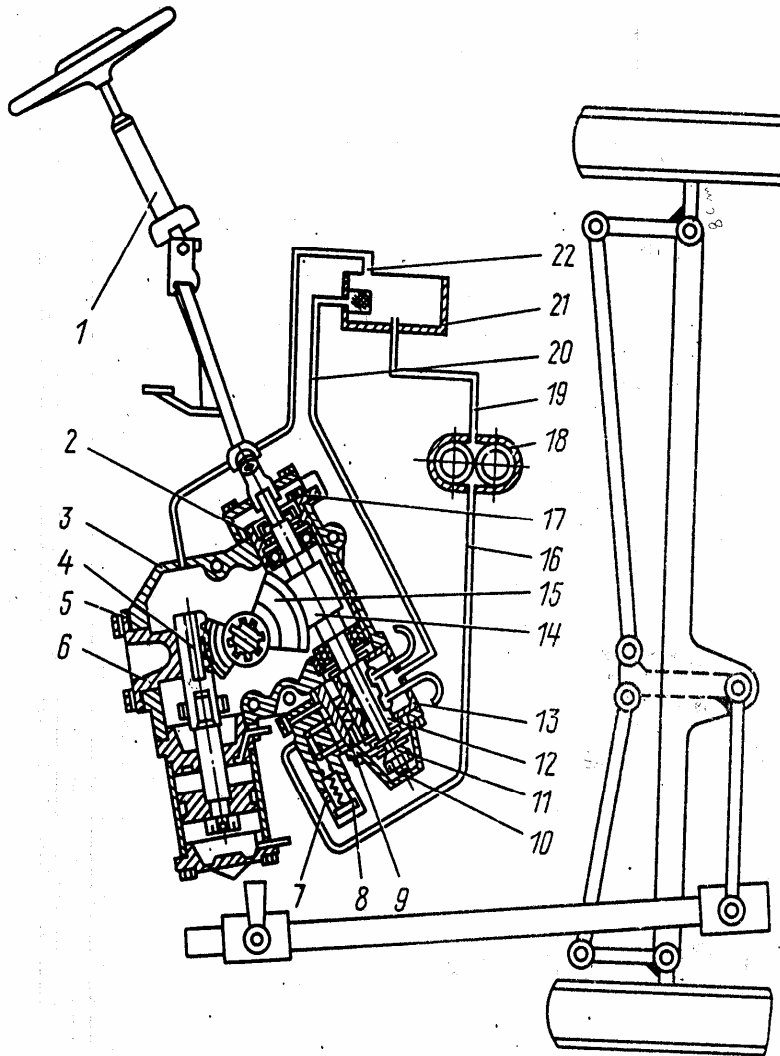

Fig. (4): Diagram of steering gear hydraulic Booster:

1- steering column ; 2- bushing ; 3- steering gear case ; 4- rack ; 5- gasket ; 6- rest 7- lock nut ; 8- screw ; 9- safety valve ; 10- cover ; 11- spherical nut ; 12 – spool ; 13- control valve housing ; 14- worm ; 15- sector ; 16- oil delivery pipeline ; 17- bolt ; 18- oil pum ; 19 – oil suction pipeline ; 20- oil return pipeline ; 21 – oil tank ; 22- oil drain pipeline (Gurevich and Sorokin,1976).

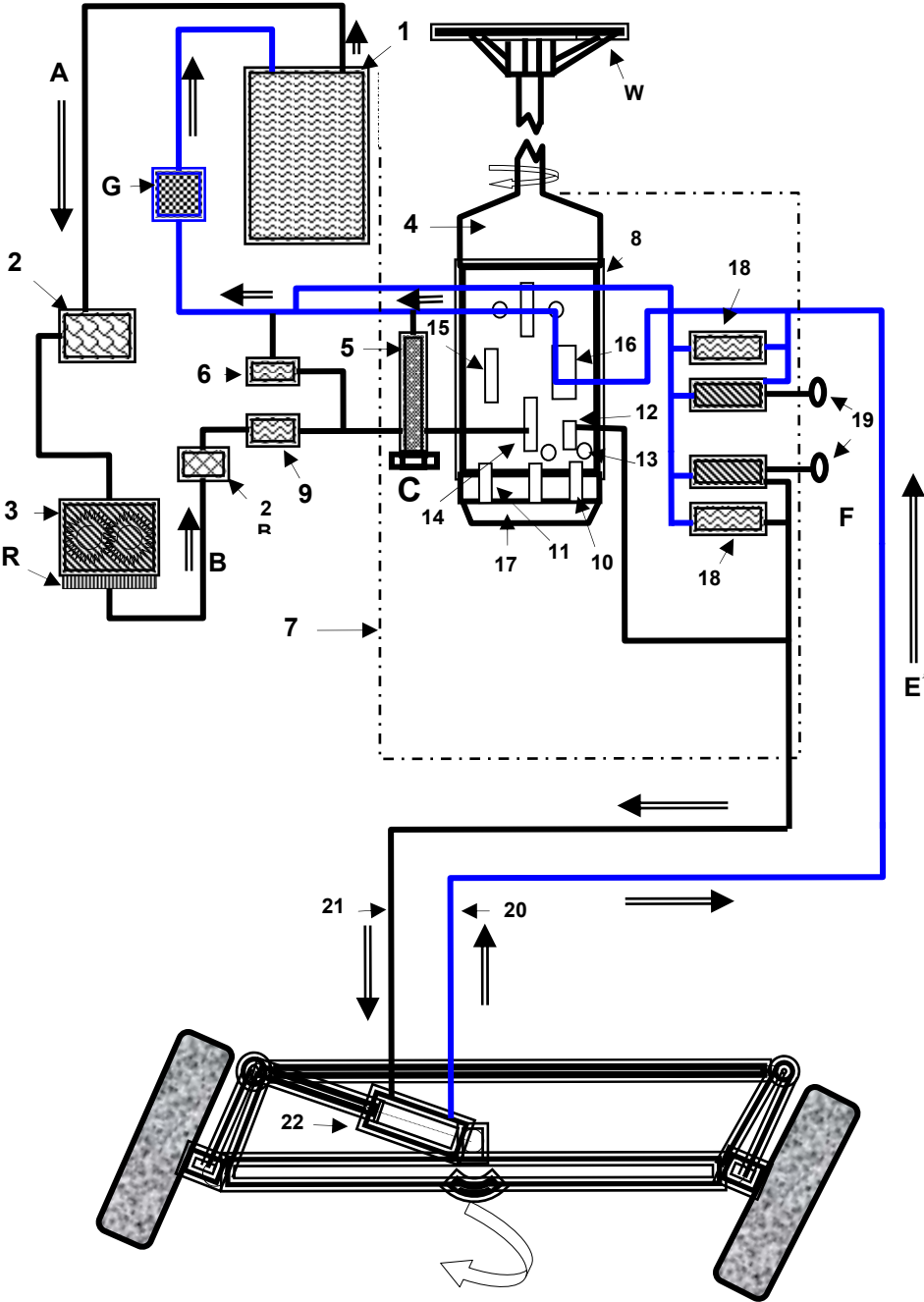

Fig. (5): Schematic drawing for apparatus of power hydraulic steering system.

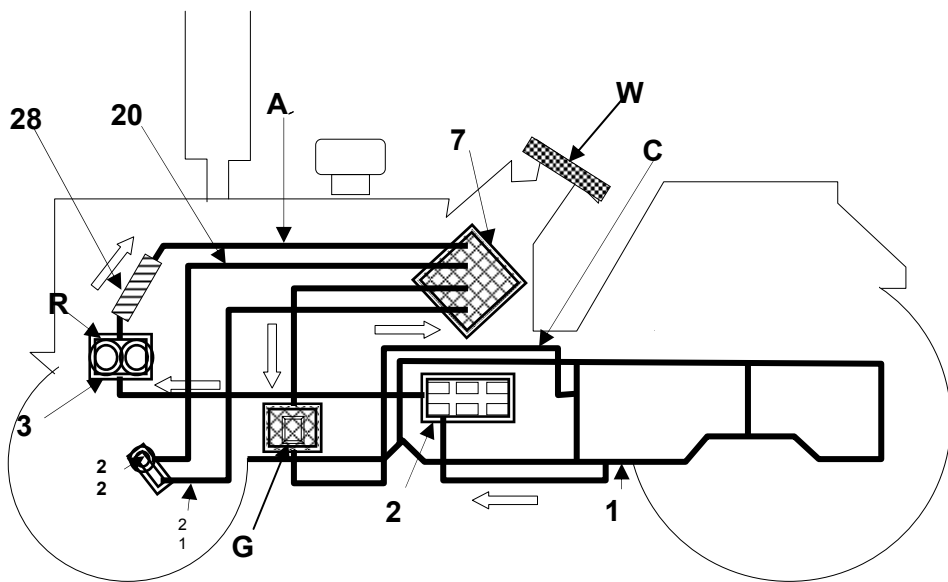

Fig. (6): Schematic drawing for power hydraulic steering system: Reservoir (transmission housing). 2- Filter on intake. 3- Hydraulic pump. 7-Hydraulic steering control valve.20-Conneting line for LH power cylinder chamber. 21- Connecting line for RH cylinder chamber. 22- Power cylinder .A-Intake. 28- Filter on delivery. G- transmission oil cooler. R- Flow regulator. C- Return. W- Steering wheel.

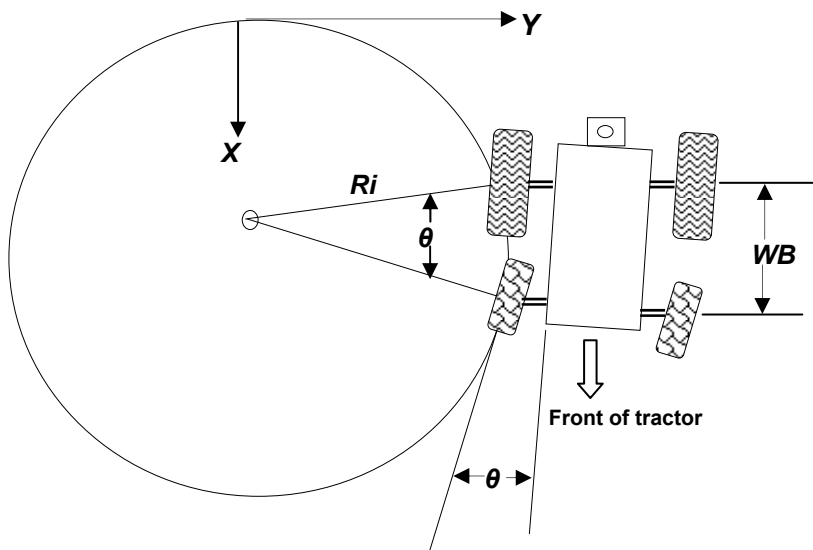

Fig. (7): Motion resulting from a constant steering wheel displacement.

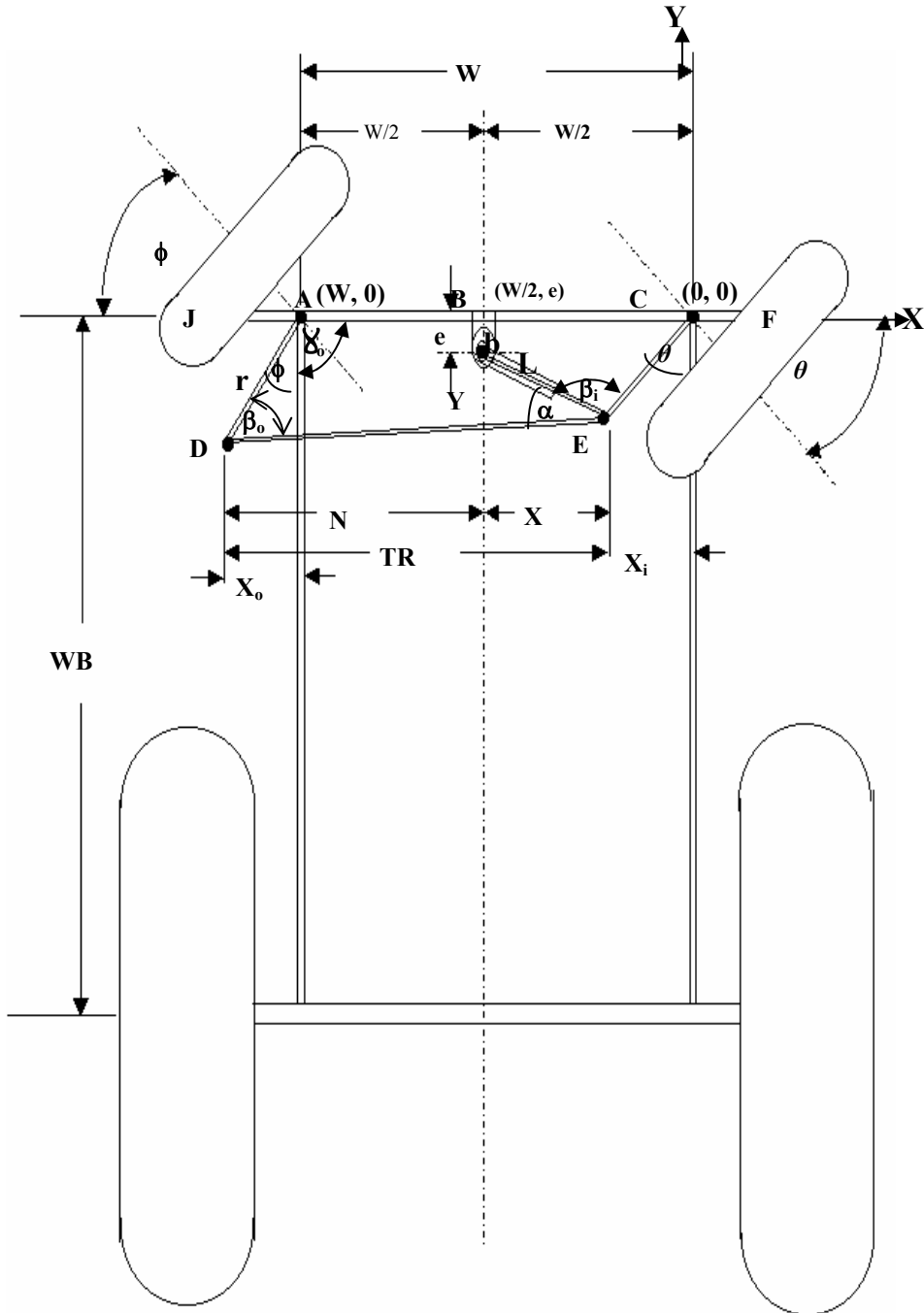

Fig. (8): Steering geometry during a turn of the tractor to the right direction and dimensions of the mechanism (θ : inner; ϕ : outer steering angles).

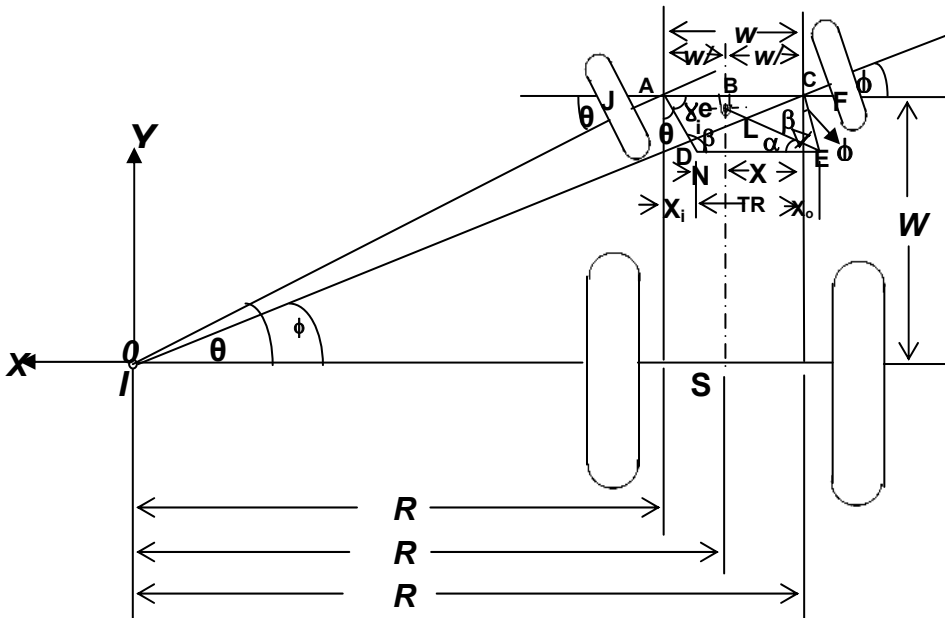

Fig. (9): Steering geometry during a turn of the tractor to the left direction (θ : inner. ϕ): outer steering angles.

From Fig. (10), it is clear that the turning radius decreased with increasing the hydraulic cylinder length at different values of W/WB , probably due to the increase of the steering angle. Values of the turning radius varied from about (671.5 to 150.5cm) at the hydraulic cylinder length varying from about (58.9 to 70.4cm), respectively for value of W/WB of about 0.45. Also, Fig. (10), indicates that the turning radius increased with values of W/WB . Values of the turning radius varied from about 356 to 514 cm at values of W/WB varying from about 0.39 to 0.58, respectively. Also, Fig. (10), shows that the maximum value of the turning radius was 845.5 cm at value of W/WB of about 0.58 for the hydraulic cylinder length 73.2 cm. Meanwhile, the minimum value of the turning radius was 116 cm at value of W/WB of about 0.39 for the hydraulic cylinder length 61.9 cm.

2- Effect of the (L/W) on the turning radius ratio to wheel base (R/WB) :

Figs (7 through 10), illustrate effect of the hydraulic cylinder length ratio to the width between the pivot points at the level of the steering arms (L/W) , the front wheels steering angles (θ, ϕ) , the piston steering angles

(∞), constant dimensions of the tractor on values of (R/WB) at different geometric proportions. The value of (R/WB) equations can be derived as follow:

(a): The perfect steering case: $\frac{R}{WB} = \frac{W}{2WB} + \frac{R_i}{WB}$ or $\frac{R}{WB} = \frac{R_o}{WB} - \frac{W}{2WB}$

(b): Actual steering case: with six methods:

A- The right direction (**R.H.Steer**): **B-**The left direction
(L.H.Steer):

$$\begin{aligned}
 1- \therefore \frac{R_o}{WB} &= \frac{r \cos \phi}{TR - \frac{W}{2} - L \cos \alpha} & \therefore \frac{R_i}{WB} &= \frac{r \cos \theta}{\frac{W}{2} - TR + L \cos \alpha} \\
 2- \therefore \frac{R_o}{WB} &= \frac{r \cos \phi}{TR - \frac{W(wb)}{WB} - L \cos \alpha} & \therefore \frac{R_i}{WB} &= \frac{r \cos \theta}{\frac{W(wb)}{WB} - TR + L \cos \alpha} \\
 3- \therefore \frac{R_o}{WB} &= \frac{\sqrt{r^2 - [TR - \frac{W}{2} - L \cos \alpha]^2}}{TR - \frac{W}{2} - L \cos \alpha} & \therefore \frac{R_i}{WB} &= \frac{\sqrt{r^2 - [\frac{W}{2} - TR + L \cos \alpha]^2}}{\frac{W}{2} - TR + L \cos \alpha} \\
 4- \therefore \frac{R_o}{WB} &= \frac{\sqrt{r^2 - [TR - \frac{W}{2} - L \cos \alpha]^2}}{TR - \frac{W(wb)}{WB} - L \cos \alpha} & \therefore \frac{R_i}{WB} &= \frac{\sqrt{r^2 - [\frac{W}{2} - TR + L \cos \alpha]^2}}{\frac{W(wb)}{WB} - TR + L \cos \alpha} \\
 5- \therefore \frac{R_o}{WB} &= \frac{\sqrt{r^2 - [TR - \frac{W}{2} - \sqrt{L^2 - Y^2}]^2}}{TR - \frac{W}{2} - \sqrt{L^2 - Y^2}} & \therefore \frac{R_i}{WB} &= \frac{\sqrt{r^2 - [\frac{W}{2} - TR + \sqrt{L^2 - Y^2}]^2}}{\frac{W}{2} - TR + \sqrt{L^2 - Y^2}} \\
 6- \therefore \frac{R_o}{WB} &= \frac{\sqrt{r^2 - [TR - \frac{W}{2} - \sqrt{L^2 - Y^2}]^2}}{TR - \frac{W(wb)}{WB} - \sqrt{L^2 - Y^2}} & \therefore \frac{R_i}{WB} &= \frac{\sqrt{r^2 - [\frac{W}{2} - TR + \sqrt{L^2 - Y^2}]^2}}{\frac{W(wb)}{WB} - TR + \sqrt{L^2 - Y^2}}
 \end{aligned}$$

Where: $\frac{R_o}{WB}$: The outer turning radius ratio to wheel base;

$\frac{R_i}{WB}$:The inner turning radius ratio to wheel base; $\frac{R}{WB}$:The turning radius ratio to wheel base.

From Fig. (10), it is clear that values of (R/WB) decreased with increasing value of L/W at different values of W/WB probably due to the increase of the steering angle. Values of (R/WB) varied from about

(2.741 to 0.614) at L/W varying from about (0.5306 to 0.6342), respectively for value of W/WB of about 0.45.

Also, Fig. (10), indicates that values of (R/WB) increased with values of W/WB. Values of (R/WB) varied from about 1.454 to 2.10 at values of W/WB varying from about 0.39 to 0.58, respectively.

B- Deviation of the turning center(DTC):

1- Effect of the hydraulic cylinder length on the (DTC):

Figs (7 through 9, and 11), illustrate effect of the hydraulic cylinder length, constant dimensions of the tractor on the value of (DTC) at different geometric proportions. The (DTC) equations can be derived as follow:

$$(DTC) = R_o - R + W/2 - W \quad ; \quad (DTC) = R_o - R + \frac{W(wb)}{WB} - W$$

When $R_o = R_i + W$ becomes: (DTC) = (0) in perfect steering case. ;
 when $R_o > R_i + W$ becomes: (DTC)=(+)Positive value; in actual steering case. ;
 When $R_o < R_i + W$ becomes: (DTC) = (-) Negative value; in actual steering case.

From Fig.(11), it is clear that the values of (DTC) decreased with increasing the hydraulic cylinder length at different values of W/WB probably due to the increase of the steering angle. Values of (DTC) varied from about (111 to 0.0 cm) at the hydraulic cylinder length varying from about (53.9 to 55.4 cm), respectively for value of W/WB of about 0.45. Also, Fig. (11), indicates that the values of (DTC) increased with the values of W/WB. Values of (DTC) varied from about 48 to 70.5 cm at values of W/WB varying from about 0.39 to 0.58, respectively. Also, Fig. (11), show that the maximum value of (DTC) was 141cm at value of W/WB of about 0.58 for the hydraulic cylinder length 68.2 cm. Meanwhile, the minimum value of (DTC) was 19.2 cm. at value of W/WB of about 0.39 for the hydraulic cylinder length 47.84 cm.

2- Effect of the (L/W) on the (DTC) ratio to the turning radius (DTC/R):

From Fig. (11), it is clear that the values of (DTC/R) decreased with increasing values of (L/W) at different values of W/WB probably due to the increase of the steering angle. Values of (DTC/R) varied from about (0.066 to 0.0) at values of L/W varying from about (0.4856 to 0.4991), respectively for value of W/WB of about 0.45.

Also, Fig. (11), indicates that the values (DTC/R) increased with the values of (W/WB). Values of (DTC/R) varied from about 0.0308 to 0.0424 at values of (W/WB) varying from about 0.39 to 0.58, respectively.

SUMMARY AND CONCLUSION

The present study was carried out by using two tractors mounted type chisel plough of 7 tines in two rows locally industrial were used, the Belarus tractor, 65B.HP (48.2 kw) was usage common and widespread

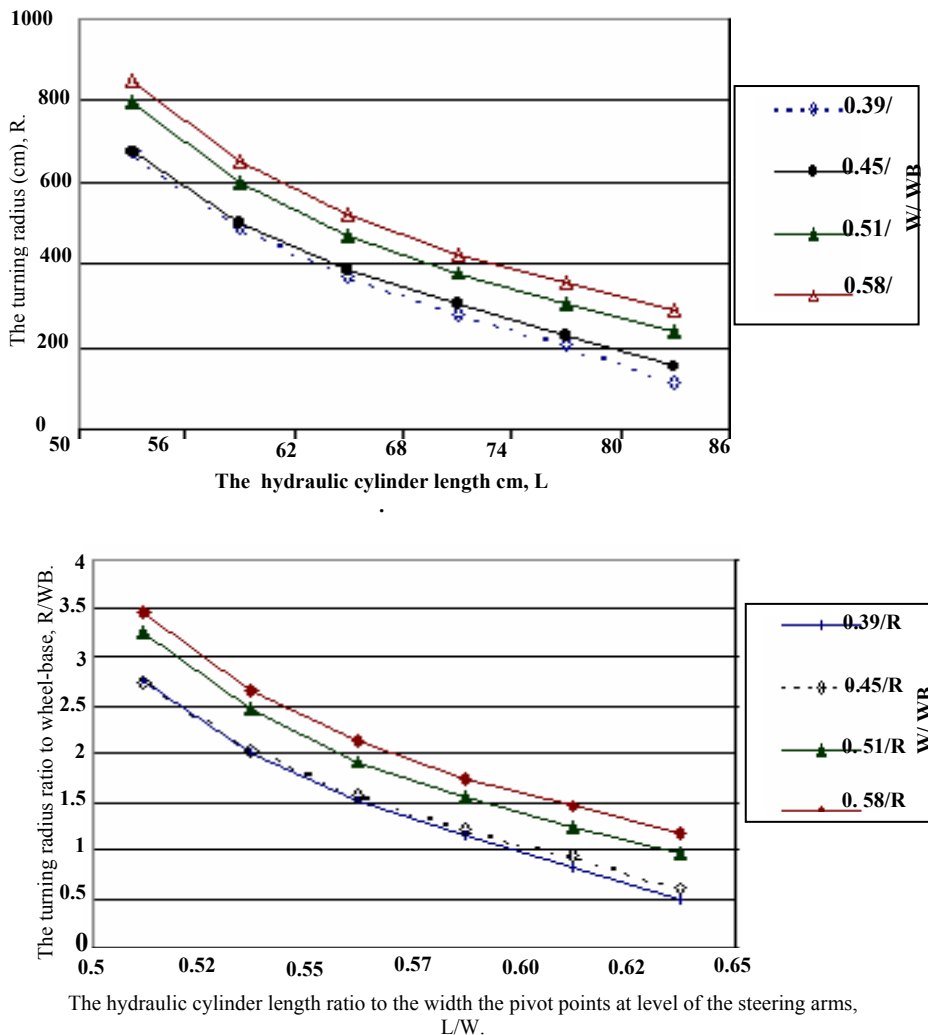

Fig.(10): Effect of the hydraulic cylinder length, the hydraulic cylinder length ratio to the width of the pivot points at level of the steering arms (L/W) on the turning radius and the turning radius ratio to wheel-base(R/WB) for 4-bar steering mechanism at the different values of W/WB.

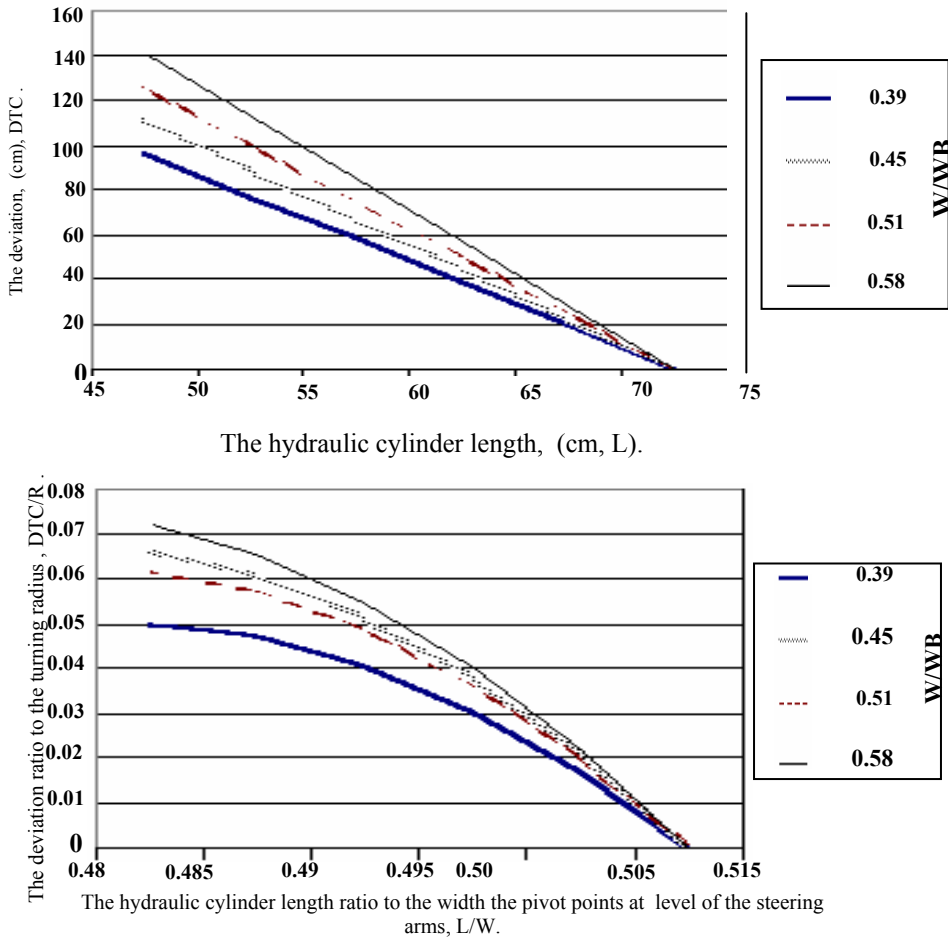

Fig.(11): Effect of the hydraulic cylinder length, the hydraulic cylinder length ratio to the width the pivot point at level of the steering arms (L/W) on the deviation and the deviation ratio to the turning radius (DTC/R) for 4-bar steering mechanism at the different values of W/WB.

under Egyptian conditions. The tractor before, after common and widespread under Egyptian conditions. The tractor before, after modification (this modification allowed tested tractor to decrease the turning radius from 5 to 1.5 m and decrease the friction between the front wheels and the steering equipments) were constructed and tested at agricultural tractors and machinery research laboratory, Agricultural Engineering Department, Faculty of Agriculture, Al-Azhar University. The main results obtained from experiments are summarized under the following main points:

A- The turning radius:

1- Effect of the hydraulic cylinder length on the turning radius:

The turning radius decreased with increasing the hydraulic cylinder length. Values of the turning radius varied from about (671.5 to 150.5cm) at the hydraulic cylinder length varying from about (58.9 to 70.4cm), respectively for value of W/WB of about 0.45.

The turning radius increased with values of W/WB. Values of the turning radius varied from about 356 to 514 cm at values of W/WB varying from about 0.39 to 0.58, respectively.

The maximum value of the turning radius was 845.5 cm at value of W/WB of about 0.58 for the hydraulic cylinder length 73.2 cm. Meanwhile, the minimum value of the turning radius was 116 cm at value of W/WB of about 0.39 for the hydraulic cylinder length 61.9 cm.

2- Effect of the (L/W) on the turning radius ratio to wheel base (R/WB):

The values of (R/WB) decreased with increasing value of L/W. Values of (R/WB) varied from about (2.741 to 0.614) at L/W varying from about (0.5306 to 0.6342), respectively for value of W/WB of about 0.45. The values of (R/WB) increased with values of W/WB. Values of (R/WB) varied from about 1.454 to 2.10 at values of W/WB varying from about 0.39 to 0.58, respectively, decrease the turning radius, decrease the agricultural operations time and increased efficiency of the tractor.

B- Deviation of the turning center(DTC):

1- Effect of the hydraulic cylinder length on the (DTC):

The values of (DTC) decreased with increasing the hydraulic cylinder length. Values of (DTC) varied from about (111 to 0.0 cm) at the hydraulic cylinder length varying from about (53.9 to 55.4 cm), respectively for value of W/WB of about 0.45.

The values of (DTC) increased with the values of W/WB. Values of (DTC) varied from about 48 to 70.5 cm at values of W/WB varying from about 0.39 to 0.58, respectively.

The maximum value of (DTC) was 141cm at value of W/WB of about 0.58 for the hydraulic cylinder length 68.2 cm. Meanwhile, the minimum value of (DTC) was 19.2 cm, at value of W/WB of about 0.39 for the hydraulic cylinder length 47.84 cm.

2- Effect of the (L/W) on the (DTC) ratio to the turning radius (DTC/R):

The values of (DTC/R) decreased with increasing values of (L/W). Values of (DTC/R) varied from about (0.066 to 0.0) at values of L/W varying from about (0.4856 to 0.4991), respectively for value of W/WB of about 0.45. The values of (DTC/R) increased with the values of (W/WB). Values of (DTC/R) varied from about 0.0308 to 0.0424 at values of (W/WB) varying from about 0.39 to 0.58, respectively.

REFERENCES

- Grovum, M.A.; and G.C.Zoerb (1970).** “An automatic guidance system for farm tractors.” Trans. **ASAE: 566-573.**
- Gurevich, A.; and Sorokin, E. (1976).** “Tractors.” Mir. Pub., Moscow: 13-16.
- Kwang Waropase, N. (1994).** “Research and development of small riding mower.” Kasetart, J. Nat., Sc., 28: 4, 608-615;2ref.
- Shukla, Lat N.; Carroll, E. Goering; and C. Leroy Day (1970).** “Effect of tractor parameters on automatic steering.” Trans. **ASAE: 678-681.**
- Smith, L.A.; L. Schafer; and R.E. Young (1985).** “Control algorithms for tractor implement guidance.” Trans. **ASAE: 415-419.**
- Smith, L.A.; Robert L. Schafer; and Alvin C. Bailey (1987).** “Verification of tractor guidance Algorithms.” Trans. **ASAE, 30 (2): 305-310.**
- Whitaker J.H. (1976).** “Steering design for adjustable tread-width tractors.” Trans. **ASAE : 422-427.**
- Zhang, Y. (1985).** “Kinematic analysis and design of tractor steering systems.” Unpub. M. Sc. Th. Univ. of Saskatchewan. Saskatoon, Canada: **116-121.**
- Zhang, Y.; R.L. Kushwaha; and F.W. Bigshy (1988a).** “Analysis of Coplanar and Independent tractor- steering systems.” Trans. **ASAE, Vol. 31(4): 1010-1014.**
- Zhang, Y.; R.L. Kushwaha; and F.W. Bigsby (1988b).** “Design of common-center-steering systems of tractors.” Trans. **ASAE, Vol.31 (4): 1015-1019.**

المخلص العربي

دراسة على كفاءة أجهزة توجيه الجرارات الزراعية

2- نصف قطر الدوران 3- الانحراف عن مركز الدوران

أبو الخير مصطفى محمد سرحان* حسني سلطان القطري** محمد نبيل العوضي***

تهدف هذه الدراسة إلى معرفة النظام الأمثل لتشغيل وصيانة الجرار الزراعي بصفة عامة والتوجيه والقيادة بصفة خاصة وبالتالي تصميم جهاز توجيه آلي يتم تشغيله بطريفة هيدروليكية بحيث تعمل كوحدة مجمعة تحت جميع خطوات التشغيل ونقل الحركة إلى عجلتي الأرض الأماميتين لتكون ذاتية التوجيه وذلك في الجرار الزراعي. ولتحقيق هذا الهدف تم اختيار جرارين من نفس النوع ومحراث 7 سلاح صناعة محلية والجرار المستخدم ماركة بيلاروس (10M3-6KM) ذات قدرة متوسطة متعدد الأغراض 65 حصان ميكانيكي (48.2 كيلوات) شائع الاستخدام تحت الظروف المصرية وأختبر ليناسب الفلاح المصري والمزارع المصرية وأستعمل الجرار قبل وبعد التعديل (وهذا التعديل يسمح بتقليل نصف قطر الدوران من 5 إلى 1.5 متر وكذلك تخفيض الاحتكاك بين العجلات الأمامية وأجهزة التوجيه) أختبر في معمل أبحاث الآلات والجرارات الزراعية بقسم الهندسة الزراعية كلية الزراعة - جامعة الأزهر.

ويمكن تلخيص أهم النتائج المتحصل عليها فيما يلي:

أ- نصف قطر الدوران: 1- تأثير طول الأسطوانة الهيدروليكية على نصف قطر الدوران:

نصف قطر الدوران يقل بزيادة طول الأسطوانة الهيدروليكية وقيمه تتراوح بين (150.5-671.5 سم) عند طول الأسطوانة تتراوح بين (70.4-58.9 سم) وبينما نصف قطر الدوران يزداد بزيادة قيم W/WB وقيمه تتراوح بين (514-356 سم) عند قيم W/WB تتراوح بين (0.58-0.39) على الترتيب

2- تأثير نسبة L/W على نسبة R/WB :

النسبة بين نصف قطر الدوران وقاعدتي العجل (R/WB) تقل بزيادة النسبة بين طول الأسطوانة إلى المسافة بين محوري العجل الأمامي (L/W) وقيمتها تتراوح بين (0.614-2.741) عند قيم L/W (0.6342-0.5306) وبينما هذه النسبة تزداد بزيادة قيم W/WB وقيمتها تتراوح بين (1.454-2.1) عند قيم W/WB (0.58-0.39) على الترتيب.

3- الانحراف: 1-3- تأثير طول الأسطوانة الهيدروليكية على الانحراف: الانحراف يقل بزيادة طول الأسطوانة وقيمه تتراوح بين (0.0-111 سم) عند طول الأسطوانة (55.4-53.9 سم) وبينما الانحراف يزداد بزيادة قيم W/WB وقيمه بين (70.5-48 سم) عند قيم W/WB (0.58-0.39) على الترتيب.

2-3- تأثير نسبة L/W على نسبة DTC/R :

نسبة الانحراف إلى نصف قطر الدوران تقل بزيادة L/W وقيمتها تتراوح بين (0.0-0.066) عند قيم L/W (0.4991-0.4856) وبينما هذه النسبة تزداد بزيادة قيم W/WB وقيمتها تتراوح بين (0.0424-0.0308) عند قيم W/WB تتراوح بين (0.58-0.39) على الترتيب. مما يؤدي إلى: 1- تقليل نصف قطر الدوران 2- تقليل زمن العمليات الزراعية 3- زيادة كفاءة الجرار.

*طالب دراسات عليا، درجة الدكتوراه، ق. هـ. ز. - ك. ز. - ج. الأزهر .

**أستاذ الهندسة الزراعية - هـ. ز. - ك. ز. - ج. الأزهر .

***أستاذ متفرغ - هـ. ز. - ك. ز. - ج. عين شمس.