

## **EFFECT OF SOME ENGINEERING FACTORS ON FEEDING DISC FOR DIRECT SEEDING OF SOAKED AND INCUBATED RICE SEEDS**

**Abo EL-Naga, M.H.M<sup>1</sup> and Shetawy. M.A. El-Said<sup>2</sup>**

### **ABSTRACT**

*Rice crop occupies the first place in area and importance in both national and local level. The cultivation of rice requires a great deal of time, energy and costs. Therefore, the main objectives of this research were conducted to study effects of some factors engineering of disc feed for direct seeding soaked and incubated rice grains. The factors under study were divided into three different feed disc speeds 0.1 , 0.15 and 0.19 m/sec and three different high fall down point grain from the feed disc 15 , 20 and 25 cm for rice variety Sakha 10. It was used in all tests after soaking at 24 hours and incubated at 48-hour.*

*The best uniformity of grain distribution achieved with C.V 6.13 and 8.05 % at feed disc speed of 0.1 m/s and high fall down point grain of 15 cm in lateral and longitudinal direction respectively. The lowest values of visible and invisible grain damage 3.33 and 0.23 % were found at feeding disc speed of 0.1 m/s and fall down grain high of 15 cm. The lowest value of the hill area 24.75 cm<sup>2</sup> was obtained with feed disc speed of 0.1 m/s and high fall down point grain of 15 cm.*

### **INTRODUCTION**

**T**he physical and mechanical properties of wet rice seeds and some engineering parameters such as velocity of feed disk and the position high of seed dropping are the majority factors effect on uniformity of seed distribution and seed damage. **Bernscki et al. (1972)** said that the steady pouring of the seed mass through orifices that is a uniform quantity of seeds delivered to the feeding sets. Due to great differences in the shape, dimensions and weight of seeds like which occur not only between particular kinds of seed but even between their varieties. Thus the process of seed emptying is a very complicated and progress of

---

<sup>1</sup> Senior Researcher, Agric.Eng. Res. Inst., Dokki, EL- Giza, Egypt.

<sup>2</sup> Lect. Agric. Eng. Dept. Fac. of Agric., Al-Azhar Univ. Egypt.

grain pouring is frequently random. They added that naturally small seeds, ball-shaped and with smooth cuticle fill the box more easily and regularly and consequently, pour out more uniformly than spindle-shaped seed (sunflower) or those with coarse cuticle or irregular in shape (beet seeds). Besides, in all cases a seed stream represents an irregular flow to a greater or lesser extent. **Klenin, et al. (1985)** stated that the productivity of seeders, planters and machines for fertilizer application is entirely dependent upon the working speed of the machine; this is governed by the power available from the tractor and the corresponding agro technical requirements. The most important of such requirements are the uniform distribution of seeds over the field, constant rate of sowing of the desired quantity of seeds, minimum seed damage and uniform depth of drilling. Uniform seed distribution depends upon the maintenance of a given seeding norm which in turn is directly dependent upon the design of the feed unit, slip of the driving wheels, and depth of filling of the seed chest and so on. To ensure uniform distribution of seeds and seedlings the spacing between adjacent seeding both in the longitudinal and transverse directions must remain constant. The factors governing uniform longitudinal and transverse distribution may be expressed in terms of variational coefficient and the axial velocity of flow depends on the diameter of the orifice for uniform distribution of seeds; the material should be continuously delivered to the seed drill and as far as possible, at uniform rate. **Ismail and El-Banna (1994)** investigated a new technique (strip-sowing) of rice planting to overcome the all disadvantage of all common methods, they found that, the maximum of seed scattering were found in the first of 3 cm for each side around the seeds dropping line at using traditional methods. While, the seeds dropping height of 20 cm recorded the highest values of latitudinal deviation around the center of seeds dropping and the best uniformity of seeds distribution was at 10 cm of seeds dropping height. Increase the seeds dropping height from 10 to 15 cm the number of plant per unit area and yield increases 0.986 and 0.98 times at soil roughness of 80.77%. **Heege (1993)** studied the seeding methods performance for cereals, rape and beans. He dealt with drilling, band sowing, broadcast sowing and precision drilling. The uniformity of the sowing depth was described by its standard deviation. The seed

distribution over an area was compared by using the mean distance to the nearest neighboring kernel with a fixed seed rate. The best seed distribution over an area with bulk-metering methods was obtained by broadcast sowing. However, the result with broadcast sowing can be surpassed by precision drilling provided a small row-spacing is used. Improving the seed distribution over the area with small grains, rape or field beans results in moderate yield increases. **Griepentrog, H. W.(1999)** stated that the placing quality of seeders influences field emergence, plant development and crop yield. Both the seeding depth and the horizontal distribution over the area must be considered to assess placing quality. Optimizing plant distances increased field emergence and yield, and decreased the competition effects of growth factors, light, water and nutrients. The seed distribution over the area depends on the quality of longitudinal distribution, row width and seed rate as a non-technical parameter. These three parameters determine the quality of horizontal seed distribution and the available single area for plant growth and development. Therefore the objectives of this work were:

- (a) Estimate some geometric, physical and mechanical properties of soaked and incubated rice grain.
- (b) Study effects of some engineering parameters such as feed disc speed and high fall down point grain on grain damage, uniformity of grain distribution and hill area.

### **MATERIALS AND METHODS**

The experiments were carried out during two sequence summer seasons 2008/2009 at Tag EL-EZZ Agriculture Research station, Dakahlia governorate To study some operating parameters of feed disc and physical and mechanical properties of soaked and incubated rice grains.

#### **1-Materials:**

##### ***1-a) The direct seeding unit:***

Manufactured unit of direct seeding of plastic materials, it consists of one seed box at capacity of 3.0 kg and feed disc at diameter of 40 and thick of 4 cm. The feed disc have 8 cells on the periphery at a hemisphere form with a diameter of 2.25 cm. the prototype sketch of a direct seeding unit shown in figure (1).

**1-b) The testing table :**

The testing table shown in figure (2). It contain of a table of alomital at dimensions of 300, 50 and 100 cm of length, width and high respectively, Conveyor Belt of rubber length of 550 cm and a width of 30 cm, Electric motor was made in Italy, 100 rpm and power of 0.7 hp (0.522 kW). one rectangular tray of iron sheet at dimensions of 25, 10 and 100 cm of width, high and length respectively to prepare a wet layer of soil. Geer box have been different speeds from 0.35 to 0.75 km/h.

**1-c ) Variety of Rice :** A variety of rice grain was used in all tests Sakha 101

**B-Instrumentations:**

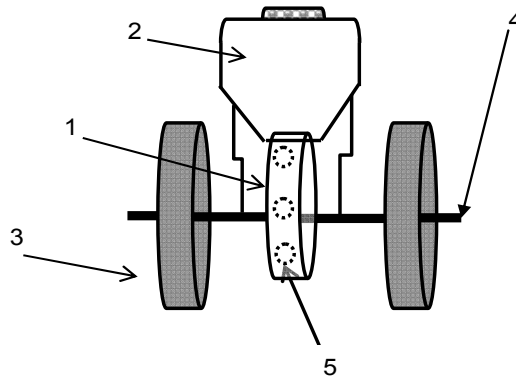

- 1- Feeding disk    2- Hopper seeds    3- land wheel
- 4- Axis bar        5- Feed cell

Fig.1 shown the prototype sketch of a direct seeding unit



Fig. 2 shown the testing table of direct seeding

**Graduated cylinder:** One liter graduated cylinder with accuracy 0.01 cm<sup>3</sup> was used to measure bulk density of rice seeds before and after soaking operation.

**Moisture content caliper:** An electrical sensitive meter (Wile 35 Moisture meter) was used for measuring the rice seeds moisture-content on wet basis.

**Scale of the wood frame:** The scale was formed from pieces of wood at section of 2.5 x 2.5 cm square-shaped at dimensions of 25 cm, all dimensions were divided by wire iron at equal distance of 1cm and fixed by a nails to obtain a square shape units at dimensions of 1 x 1 cm. The scale was used to calculate the number of rice grains per unit area (1cm<sup>2</sup>) from the two directions to measure the uniformity of seed distribution on the field.

**Coefficient of friction ( $\mu$ ):**

The coefficient of friction for each grains samples under study was measured with friction surface of plastic materials by using a digital measuring device. It measured by using the inclined plane apparatus. A thin layer of rice grains soaked and compost placed on the testing plate; the wheel of the apparatus rounded slowly and smoothly until 75 % of grains slide down the surface. The angle of inclination of the plate with the horizontal direction measured as follow:

$$\mu = \tan \theta \text{-----} (1)$$

**Repose angle ( $\theta$ ):**

A little of rice grains soaked and compost were fallen from height of 20 cm, it forms a heap. Through it is height and diameter of base, the angle of repose calculated according to the following equation:

$$\theta = \tan^{-1} \frac{2h}{d} \text{-----} (2)$$

Where:

h: height of the base, cm

d: diameter of the base, cm

**Shape index:**

A random sample of one hundred grains was taken from each sample before and after soaked and compost processes. The shape of each grains sample was studied in terms of length (L), width (W), and thickness (T<sub>h</sub>). The obtained data were used to calculate the shape index of each sample, according to **Ismail (1988)** equation.

$$\text{Shape index (SI)} = \frac{L}{W.T_k} \text{ ----- (3)}$$

At shape, index >1.5 the grain considered oval and ≤ 1.5 the grain considered spherical.

**Mass of 1000 grains (W):**

To estimate the mean mass of 1000 grains, samples of grains taken randomly and each of samples weighted using an electronic balance with an accuracy of 0.02 g.

**2-Methods:**

All tests were carried to estimate the effects of engineering parameters on grain damage (visible and invisible grains) and the uniformity of grain distribution. The experimental study were divided as the following:

- Three different feed disk speed 0.1, 0.15 and 0.19 m/s.
- Three different high fall down point grain 15, 20 and 25 cm.

Rice grains were soaked in water for 24 hours and incubated for 48 hours before they are put on the seedbed. This germination process, assures a quick and even start of the seedbed.

**Uniformity of grain distribution:**

Uniformity of grain distribution was measured by using the deviation in the longitudinal and lateral direction from average numbers of grains at standard area (1 x 1 cm). The deviation of grains from average numbers of grains estimated according to the following equation:

$$C.V = \frac{\sigma_{n-1}}{\bar{X}} \times 100 \text{ ----- (4)}$$

Where:

C.V = coefficient of variation in the longitudinal or lateral direction from the average number of grains at constant standard unit area.

$\bar{X}$  = value of grains at standard variable.

$\sigma_{n-1}$  = standard deviation

$$\sigma_{n-1} = \sqrt{\frac{\sum x^2 - \frac{(\sum x)^2}{n}}{n - 1}} \text{ ----- (5)}$$

Where:

$\Sigma x$  = summation of number of grains on the longitudinal or lateral direction.

$\Sigma x^2$  = summation of square numbers of grains on the longitudinal or Lateral direction.

$n$  = number of reading.

The coefficients of variation under 10% are considered excellent and with values, fewer than 20% generally considered acceptable for must field application as reported by **Coates (1992)**.

***Visible grain damage:***

Visible grain damage determined by using convex lens for each sample before and after passing through feed disk. The percent of visible grain damage calculated by the following equation;

$$V_d = \{(V_1 - V_2)/V_1\} \times 100 \text{ ----- (6)}$$

Where:

$V_1$  = number of damage grains in sample(500 grains)before passing.

$V_2$  = number of damage grains in sample (500 grains) after passing.

***Invisible grain damage:***

Invisible grain damage determined by using germination test, a randomized sample of 100 grains visible unharmed were taken and planted in Petri dishes, the results were recorded after ten days from planting and the germination percentage calculated by the following equation;

$$I_d = \{(N_2 - N_1) / N_2\} \times 100 \text{ ----- (7)}$$

Where:

$N_1$  = number of growing grains

$N_2$  = number of planting grains (100 grains)

***Total grain damage:***

Total grain damage was calculated by the following equation;

$$T_d = V_d + I_d \text{ ----- (8)}$$

Where:

$V_d$  = Visible grain damage, (%)

$I_d$  = Invisible grain damage, (%)

***The hill area:***

the hill area was calculated by the number of cells, scale wooden frame, which was distributed by the grains in both the longitudinal and transverse directions where every cell area equal  $1\text{cm}^2$ .

## RESULT AND DISCUSSION

### 1- Some Physical and mechanical properties and geometric characteristics of soaked and incubated rice grains:

Data in Table 1 refers to some geometric, physical and mechanical characteristics of rice grains before and after soaking and incubating. Because of these findings have an important role in the field of design, development and manufacturing of seeding direct machine. As well as conduct in damage and distribution uniformity of rice grains after soaking and incubating.

**Table (1).Geometric, physical and mechanical properties of rice grains before and after soaked and incubated process.**

The characteristics	The mean values	
	Before	After
	soaked and incubated process	
Av. Length ( L).....mm	8.19	8.40
Av. Width ( W)..... mm	3.34	3.55
Av. Thickness0. ( T)..... mm	2.17	2.40
Av. Volume ( V).....mm <sup>3</sup>	31.08	71.57
Av. Geometric diameter ( D <sub>g</sub> ).....mm	3.14	4.15
Av. Arithmetic diameter ( D <sub>a</sub> ).....mm	4.57	4.78
Av. Flat surface area ( A <sub>f</sub> )..... mm <sup>2</sup>	21.48	23.42
Av. Sphericity ( S).....%	38.34	49.40
Av. Transverse surface area of the individual seed ( A <sub>t</sub> ).....mm <sup>2</sup>	49.13	53.91
Av. Coefficient of friction (Seed/metal of plastic)	0.51	0.67
Repose angle..... degree	32.3	36.42
Shape index	3.04	2.88
Weight of 1000 grains..... g	27.44	35.13
Real density..... g/cm <sup>3</sup>	0.67	1.24
Grain moisture content..... w.b %	8.63	26.40

#### The grain damage:

##### Visible grain damage:

Results represented in figures (3-a) and (3-b) show that the visible grain damage increases with increase in feed disc speed under different high fall



down point grain from feed disc. This is owing to the friction between all grains as well as between the grains and the cover surface from the inside of feed disc. Also the visible grain damage increases with increase in high fall down point grain, this due to increase in drop force of grain. Therefore, the increase in feed disc speed from 0.1 to 0.19 m/s increased the visible grain damage by 2.37, 2.53 and 2.9 % at high fall down point grain of 15, 20 and 25 cm respectively while, the increase in high fall down point grain from 15 to 25 cm increased the visible grain damage by 1.32, 1.47 and 1.76% at feed disc speed of 0.1, 0.15 and 0.19 m/s respectively. However, the highest value of visible grain damage of 3.47 % was obtained at feed disc speed of 0.19 m/s and high fall down point grain of 25 cm, while the lowest value of visible grain damage of 3.33 % was obtained at feed disc speed of 0.1 m/s and high fall down point grain of 15 cm. as well as in the hand direct seeding the highest and lowest value of visible grain damage 3.24 and 3.22 % were achieved at high fall down point of grain of 15 and 25 cm. respectively.

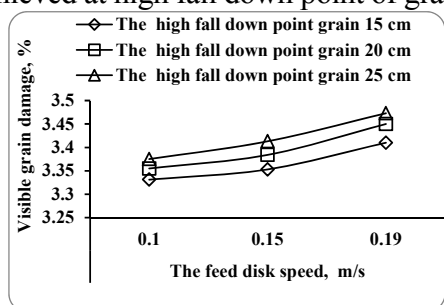

Fig. (3-a) Effect of feed disc speed and high fall down point grain on visible grain damage.

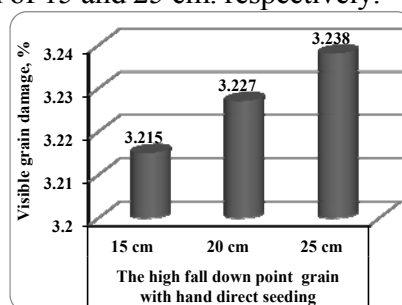

Fig. (3-b) Effect of high fall down point grain on visible grain damage with hand direct seeding.

### Invisible grain damage:

In figures (4-a) and (4-b) data shows that the same trend for effecting as in visible seed damage while all effects were less than visible seed damage. Therefore, the increase in feed disc speed from 0.1 to 0.19 m/s the invisible grain damage increased by 3.48, 3.86 and 4.25 % at high fall down point grain of 15, 20 and 25 cm respectively, while the increase in high fall down point grain from 15 to 25 cm the invisible grain damage increased by 2.17, 2.56 and 2.94% at feed disc speed of 0.1, 0.15 and 0.19 m/s respectively. However, the highest value of invisible grain damage 0.25 % was obtained at feed disc speed of 0.19 m/s and high fall down point grain of 25 cm while the lowest value of invisible grain damage 0.23 % was obtained at feed disc

speed of 0.1 m/s and high fall down point grain of 15 cm. In the other side and in the hand direct seeding the highest and lowest values of invisible grain damage 0.25 and 0.23 % were obtained at high fall down point grain of 15 and 25 cm. respectively.

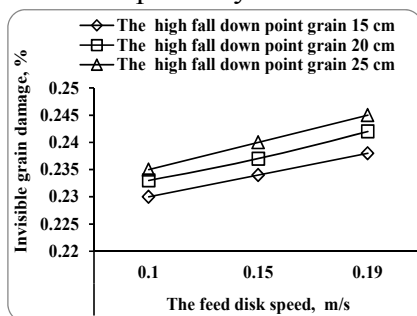

Fig. (4-a) Effect of feed disk speed and high fall down point grain on invisible grain damage.

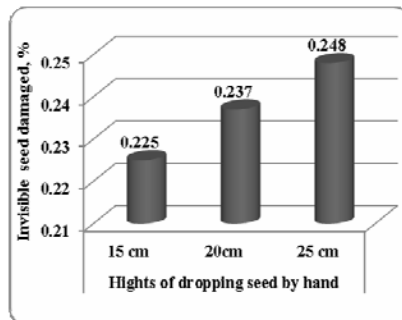

Fig. (4-b) Effect of high fall down point grain on invisible grain damage with hand direct seeding.

**The hill area:**

In figures (5 - a) and (5 - b) the results indicated that, the hill area increased with the increase in feed disc speed and high fall down point grain, this is owing to the increase in the amount time of fall down grain. In addition, when the high fall down point grain increase the hill area increase, this is due to drop force and scattering of grain. Therefore the increase in feed disc speed from 0.1 to 0.19 m/s the hill area increased by 28.52, 34.34 and 38.94 % at high fall down point grain of 15, 20 and 25 cm respectively while the increase in high fall down point grain from 15 to 25 cm the hill area increased by 25.33, 30.34 and 35.49% at feed disc speed of 0.1 , 0.15 and 0.19 m/s respectively.

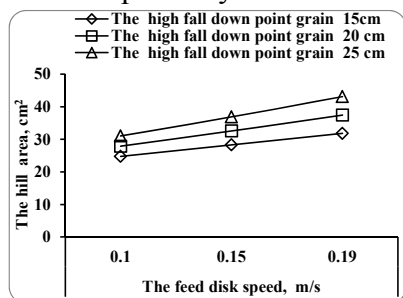

Fig. (5-a) Effect of feed disc speed and high fall down point grain on hill area.

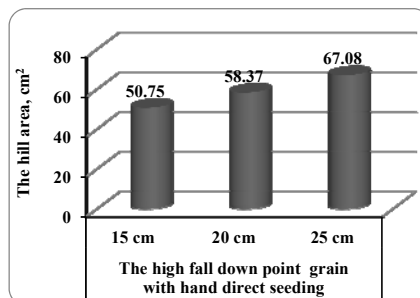

Fig. (5-b) Effect of high fall down point grain on hill area with hand direct seeding.

However, the highest value of the hill area 43.1 cm<sup>2</sup> was achieved at feed

disc speed of 0.19 m/s and high fall down point grain of 25 cm, while the lowest value of the hill area 24.75 cm<sup>2</sup> was obtained with feed disc speed of 0.1 m/s and high fall down point grain of 15 cm. Also in the hand direct seeding the highest and lowest values of the hill area 67.08 and 50.75 cm<sup>2</sup> were achieved at high fall down point grain of 25 and 15 cm. respectively.

### Uniformity of grain distribution:

#### At lateral direction:

The data in figures (6-a) and (6-b) mentioned that the coefficient variation of uniformity of grain distribution increased with the increase in feed disc speed and high fall down point grain this is owing to the increase in the scattering, trouble in the distribution and the drop force of grains. Also the increase in high fall down point grain with hand direct seeding the values of coefficient variation increase. Therefore the increase in feed disc speed from 0.1 to 0.19 m/s the coefficient variation value increased by 47.15, 59.65 and 68.37 % at high fall down point grain of 15, 20 and 25 cm respectively while, at the increase of high fall down point grain from 15 to 25 cm the coefficient variation value increased by 40.29, 50.13 and 60.23% at speed feeding disc of 0.1, 0.15 and 0.19 m/s respectively. However, the highest value of C.V 14.48 % was obtained at feed disc speed of 0.19 m/s and high fall down point grain of 25 cm. While the lowest value of C.V 6.13 % was obtained at feed disc speed of 0.1 m/s and high fall down point grain of 15 cm. As well as in the hand direct seeding the highest and lowest value of C.V. 21.07 and 12.81% were obtained at high fall down point grain of 25 and 15 cm. respectively.

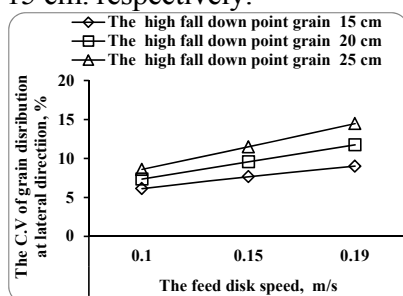

Fig. (6-a) Effect of feed disc speed and high fall down point grain on uniformity of grain distribution at lateral direction.

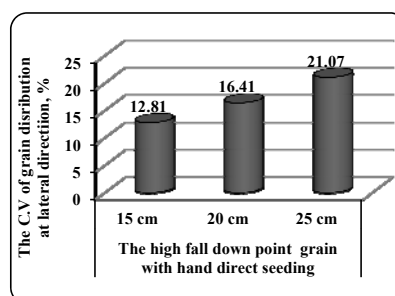

Fig. (6-b) Effect of high fall down point grain on uniformity of grain distribution with hand direct seeding at lateral direction.

#### At longitudinal direction:

In figures (7-a) and (7-b) the data indicated that the increase in feed disc speed from 0.1 to 0.19 m/s increased the coefficient variation of uniformity of grain distribution by 44.72, 56.44 and 64.87 % at high fall down point grain of 15, 20 and 25 cm respectively, while the increase in high fall down point grain from 15 to 25 cm the coefficient variation increased by 47.55, 55.35 and 67.98% at feed disc speed of 0.1, 0.15 and 0.19 m/s respectively. However, the highest value of C.V. 19.57% was obtained at feed disc speed of 0.19 m/s and high fall down point grain of 25 cm. While the lowest value of C.V. 8.05 % was obtained at feed disc speed of 0.1 m/s and high fall down point grain of 15 cm. As well as in the hand direct seeding the highest and lowest value of C.V. 21.07 and 12.81% were obtained at high fall down point grain of 25 and 15 cm. respectively.

]

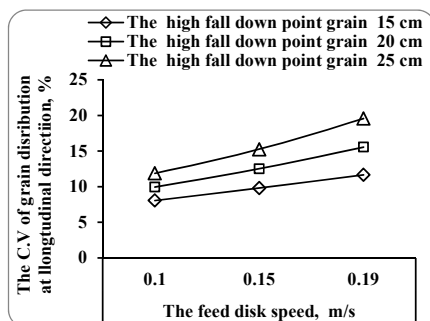

Fig. (7-a) Effect of feed disc speed and high fall down point grain on uniformity of grain distribution at longitudinal direction.

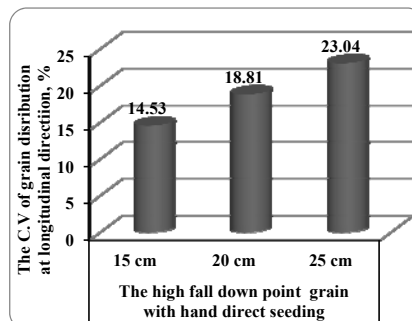

Fig. (7-b) Effect of high fall down point grain on uniformity of grain distribution with hand direct seeding at longitudinal direction.

### CONCLUSION

All laboratory and measurements tests were carried out on Sakha-101 variety of rice before and after soaking and incubation process to determine some geometric, physical and mechanical properties to study the effects of some engineering parameters such as feed disc speed and high fall down point grain on grain damage, hill area and uniformity of grain distribution. The collecting data were taken as a fundamental basic for a developing and introducing a direct seeding machine for sowing soaked and incubated grain rice. The results could be summarized as following:

- The lowest value of the hill area 24.75 cm<sup>2</sup> was obtained with feed disc

speed of 0.1 m/s and high fall down point grain of 15 cm.

- The lowest value and invisible of visible grain damage of 3.33 and 0.23 % was obtained at feed disc speed of 0.1 m/s and high fall down point grain of 15 cm.
- The best uniformity of grain distribution in lateral and longitudinal direction achieved with C.V 6.13 and 8.05 % at feed disc speed of 0.1 m/s and high fall down point grain of 15 cm.

### REFERENCES

- Bernski H., H. Haman and Kana Fojski C. Z. (1972)** Agricultural machine theory and construction vol. (1) part (2) U.S department of commerce, National technical information service (NTIS) 626.
- Coates, W. (1992)** Performance evaluation of a pendulum spreader. Trans. ASAE, 8 (3): 285-288.
- El-Raie, A. E. S; N. A. Hendawy and A. Z. Taib (1996)** Study of physical and engineering properties for some agricultural products. Misr. J. Agric. Eng.13(1): 211-226.
- Griepentrog, H. W.(1999)** On assessing seed distribution over area. Agrartechnische Forschung, 1999, Vol.5, No.2, pp.117-124, 19 ref.
- Heege H, J. (1993)** Seeding methods performance for cereals, rape, and Beans. Trans. ASAE. 36 (3) : 653 – 661.
- Ismail, Z. E. (1988)** Same of the phsio-mechanical properties for potato tubers. J. Agric. Sic. Mansoura Univ. 13 B(4):2259-2270.
- Ismail, Z.E. and El-Banna E.B. (1994)** Developing a drilling machine for strip-sowing method of rice crop”. Misr J. Agr. Eng., 11 (3): 605-614.
- Klenin, N.I. ; Povo, I.F. and Sakum, V.A. (1985)** Agricultural machines, Amerind Pub. Co. N. Y. : 129-153, 186-189.

### الملخص العربي

## تأثير بعض العوامل الهندسية لقرص التلقيح في الزراعة المباشرة لبذور الأرز المنقوعة والمكمورة

محمد حمزه مخيمر أبو النجا<sup>1</sup> محمد احمد السيد شتيوى<sup>2</sup>

يحتل محصول الأرز المرتبة الأولى من حيث المساحة والأهمية على المستويين العالمي والمحلى وتستنفذ عملية الزراعة القدر الأعظم من الطاقة والتكاليف ويعد التطوير في نظم الزراعة المباشرة أحد جوانب المساهمة فى النهوض ب محصول الأرز وعليه تمثل الهدف الرئيسى لهذا البحث فى دراسة تأثير بعض العوامل الهندسية لقرص التلقيح للزراعة المباشرة لبذور الأرز المنقوعة والمكمورة وذلك للحد من مقدار الطاقة والتكاليف المستهلكة وتمثلت عوامل الدراسة فى ما يلى :

1. ثلاث سرعات لقرص التلقيح (0,1 و 0,15 و 0,19 متر/ثانية)
2. ثلاث إرتفاعات لنقطة سقوط البذرة من قرص التلقيح (15 و 20 و 25 سم)
3. دراسة بعض الصفات الهندسية والفيزيائية والميكانيكية لبذور الأرز قبل وبعد عملية النقع والكمر.

و تمثلت جوانب البحث فى دراسة العوامل سالفة الذكر وتأثيرها على التلف المنظور وغير المنظور ومساحة إنتشار البذور فى الجورة أيضاً إنتظام توزيع البذور فى كلا الإتجاهين العرضى والطولى مقارنته بطريقة الزراعة اليدوية المباشرة (الزراعة باللقمة). وأختير الصنف سخا 101 لمحصول الأرز لإجراء الإختبارات بعد عملية النقع فى الماء العذب لمدة 24 ساعة وعملية الكمر لمدة 48 ساعة وأجريت الإختبارات بمحطة البحوث الزراعية بتاج العز- دقهلية خلال موسمى 2008 و 2009 وأظهرت الاختبارات النتائج التالية:

تحقق أفضل إنتظام لتوزيع البذرة فى الاتجاه العرضى و الطولى مع سرعة 0,1 لفة/ثانية لقرص التلقيح وارتفاع 15 سم لنقطة سقوط البذرة حيث كانت قيمة معامل الاختلاف 6,13 و 8,05 % على التوالى .وكانت أقل قيمة لنسبة تلف البذور المنظور للغير منظور 3,33 و 0,23 % مع سرعة 0,1 لفة/ثانية لقرص التلقيح وارتفاع 15 سم لنقطة سقوط البذرة على التوالى بينما كانت أقل مساحة لإنتشار البذور 24,75 سم<sup>2</sup> مع سرعة 0,1 لفة/ثانية لقرص التلقيح وارتفاع 15 سم لنقطة سقوط البذرة.

<sup>1</sup>باحث أول بمعهد بحوث الهندسة الزراعية - الدقى - الجيزة - مصر.  
<sup>2</sup>مدرس الهندسة الزراعية - كلية الزراعة - جامعة الأزهر- القاهرة.