

PREDICTION OF SUNFLOWER CROP YIELD USING COMPUTER SOFTWARE APPLICATION

Aboukarima, A. M.^{1,2} and M. Minyawi¹

¹ **Agriculture Engineering Research Institute, Agriculture Research Centre, P. O. Box 256, Cairo, Dokki, Giza, Egypt**

² **Community College, Huraimla, Shaqra University, P.O. Box 300, Huraimla 11962, Saudi Arabia**

ABSTRACT

Agricultural yield prediction procedures are often proposed to explore for techniques or models that discover the practical relationship between influencing variables and production. In this research an Adaptive Neuro-Fuzzy Inference System (ANFIS) was used to build a model to predict sunflower crop yield grown in Egypt. The inputs to ANFIS were crop head diameter, seed numbers in the head, seed moisture content and pre-harvest losses. The output was sunflower seed crop yield. ANFIS membership function "the triangle" generally gave the most desired results with respect to mean error, root mean square error and coefficient of determination (R^2) statistical performance testing tools. The results revealed that ANFIS model was able to predict sunflower yield with a satisfactory performance with mean error of 18 kg/fed in testing phase. Coefficient of determination between ANFIS output and actual yield was 0.996 for testing data. However, the mean error and R^2 values were 33.8 kg/fed and 0.702 when using multiple linear regression model in yield prediction. The results demonstrate that ANFIS can be applied successfully and provide high accuracy and reliability for sunflower crop yield prediction. The findings of this research could be used as a crop management tool.

Keywords: Sunflower yield, prediction, fuzzy logic, regression.

INTRODUCTION

Sunflower crop represents one of the most important sources of oil in Egypt. Besides, Egyptian farmers are encouraged to cultivate sunflower crop because it stays in the field for a short duration (90-110 days) and can be grown twice in a year and it grows in different soil type and climate conditions (Hassan, 1999 and 2008; Aowad and Mohamed, 2009; El-Saidy *et al.*, 2011). It is fully fit in Egyptian cropping system and can be grown without causing competition of any major crop (El-Saidy *et al.* (2011). In Egypt, sunflower crop is cultivated on a smaller scale (Guvén and Sherif, 2010) and the total production is 24 thousand tons per ha and an average yield of 2.4 tons per ha (FAO, 2010). The cultivated area of sunflower is limited in Nile Valley and the Delta in Egypt due to the competition with other important summer crops. However, it could be cultivated in newly reclaimed soils in the desert area (Abdel-Wahab *et al.*, 2005). Egyptian sunflower oil can be used as an effective source of unsaturated fats and natural antioxidants. Hence, can be supplemented in many foods and can replace the synthetic antioxidant with their remarkable hazards (Hamed *et al.*, 2012). Per 100 g the sunflower seed enclose protein up to 20.78 g, total lipid (fat) up to 51.46 g, ash up to 3.02 g, fibre up to 8.6 g with total energy of 2445 kJ. The oil accounts for 80% of the value of the sunflower crop (USDA, 2008).

Crop management means that some of the affecting factors on crop yield can be modified by farmer interactions and intervention, while others are controlled by nature. Such management could be achieved by developing mathematical models. Given that the most important uses of models is to forecast the results produced by a given system in response to a given set of inputs (Dourado-Neto *et al.*, 1998). The potential use of models also comes from their aptitude in helping to set research priorities (Ruttan, 1983). Models can also supply quantitative descriptions for a system if the knowledge is missing and helping in the design of more adequate and effective experiments (France and Thornley, 1984). Besides, they play an important role in scientific research and resource management (Graves *et al.*, 2002). El-Marsafawy (2006) also reported that computer programs applications could assist researchers, decision makers and planners in identifying strategies that are desirable economically and environmentally. They can be serving as an analytical tool to study the effect of cropping systems management on productivity and the environment.

Agricultural yield prediction procedures are proposed to explore for techniques or models that discover the practical relationship between influencing variables and production (Thongboonnak and Sarapirome, 2011). There are both linear models such as linear regression and non-linear models such as Artificial Neural Network (ANN) and Adaptive Neuro-Fuzzy Inference System (ANFIS). Furthermore, prediction of crop yield is significant in order to accurately meet market requirements and proper administration of agricultural activities directed towards enhancement in production (Jayaram and Marad, 2013). Besides, seed yield is the combined function of different components and it is a complex character depending upon a large number of parameters (Abd El-Mohsen *et al.*, 2013). Fortunately, the findings of recent literature confirm that crop yield is predictable from different variables.

Stathakis *et al.* (2006) explored the use of ANFIS technique for predicting crop yield. The input to ANFIS were several parameters derived from crop growth simulation model including soil moisture content, above ground biomass, and storage organs biomass. In addition, normalized difference vegetation index was used as input. The deviation of the estimates was evaluated compared to the yield of the year that is left out and the average forecasting accuracy was good.

Zaefizadeh *et al.* (2006) predicted the barley yield per unit plot from one thousand grain, fertile tillers and main spike using an ANN model and multiple linear regressions (MLR). Results showed that in the ANN technique, the mean deviation index of estimation significantly was one-third of its rate in the MLR.

Zhang *et al.* (2008) employed an ANN model for cotton yield prediction. The results indicated that the model was a superior methodology for accurately setting cotton yields.

Krishna and Prajneshu (2008) used the data from Venugopalan and Shamasundaran (2005) to apply ANFIS technique to forecast banana yield at different stages of its growth using a number of predictors like number of leaves, plant height, plant girth, leaf length, and leaf breadth, number of hands/bunch and number of fingers/hand. Out of total data for 100 banana

plants, data for 80 banana plants is used for training while data for remaining 20 plants is used for testing. The results revealed that ANFIS provide attractive way to banana yield from the selected variables.

Lin and Hill (2008) used an ANN model with up to 21 environmental inputs to predict yields of sweet peppers produced in greenhouses. The results revealed that ANN model was a good tool for such prediction.

George and Ioanna (2009) evaluated ANFIS technique for fruit production forecasting of some agriculture products (olives, lemons, oranges, cherries and pistachios). The model utilized a time series of yearly data. ANFIS used a combination of the least-squares method and the backpropagation gradient descent method to estimate the optimal food forecast parameters for each year.

Kumar (2011) used ANFIS technique to map relation between climatic data and crop yield. The visual observation based on the graphical comparison between observed and predicted values and the qualitative performance assessment of the model indicated that ANFIS can be used effectively for crop yield forecasting.

Ibrahim (2012) developed ANN and MLR models to simulate barley grain yield. The models were constructed using the field data. The inputs to the models were plant height and number of spikes/m². The output layer neuron consists of grain yield of barley. The results revealed that ANN model produced more accurate yield predictions than MLR model.

Taki and Haddad (2012) created an ANN model to predict greenhouse tomato production. The model can predict output yield based on human power, machinery, diesel fuel, chemical fertilizer, water for irrigation, seed and chemical poisons. The results of ANN analyse showed that the (7-10-10-1), namely, a network having ten neurons in the first and second hidden layer was the best-suited model estimating the greenhouse tomato production.

Jayaram and Marad (2013) employed ANFIS technique for crop yield prediction. They used physio morphological features of sorghum as inputs. These features were days of 50 percent flowering, dead heart percentage, plant height, panicle length, panicle weight and number of primaries. The results showed that ANFIS predicted yield values in accurate way.

Qaddoum *et al.* (2013) used evolving fuzzy neural network model to predict tomato yield. The parameters used by the predictor consist of environmental variables inside the greenhouse, namely, temperature, CO₂, vapour pressure deficit, and radiation, as well as past yield. The results showed that the evolving fuzzy neural network model predicted weekly fluctuations of the yield with an average accuracy of 90%.

Sunflower seeds are easy to harvest. Sunflower heads can be left to dry on the stem or removed from the stem and dried indoors. The moisture content of a crop not only affected the harvesting process, but also the price received for the crop and storage factors (Griffin, 1976). He also added that pre-harvest losses are those which occurred in the field before combining and such losses show a grain on the ground as a result weather conditions or others. The harvesting losses of sunflower crop are influenced by the

moisture content of sunflower heads, which must be dried partially before harvesting or threshing (Ministry of Agriculture and Land Reclamation, 1990). Harvesting should take place when seed moisture content reaches 30% or less. Oil quality does not suffer between 15-30% moisture content (Cook, 2008). Besides, Hassan (1999) emphasized on the initial moisture content of the harvested sunflower heads could be vary between 7.5 to 13.5%. These variations in moisture contents ranges may be due to harvesting sunflower crop at different days. During harvesting sunflowers, there are three main sources of harvest loss (Fritz, 2008). First is loss in the standing crop ahead of the combining, which called pre-harvest losses. The pre-harvest loss in the standing crop is estimated by counting the seeds in a 1-meter square in random places across the field.

Although ANFIS technique has been applied for prediction purposes in several studies, few of these have contributed to the field of agricultural engineering research. The main goal of the present study is to develop predicting models using an ANFIS and multiple linear regression (MLR) techniques for forecasting sunflower yield in Egypt. The parameters used by the models consist of four variables namely, head diameter, number of seeds per head, moisture content of seeds, and pre-harvest losses.

MATERIALS AND METHODS

Experiment site and procedures for data collection

To study the function of ANFIS technique in predicting sunflower yield, measurable data from sunflower field were collected through season of 2013. This field is located at Nubaria region, Egypt. However, the region of Nubaria is located in North West of the Delta 47 km south of Alexandria. The total area of the region is around 5670 km². It lies at longitudes 30° 10' and latitudes 30° 52' (Abou-Hadid *et al.*, 2010). The sunflower crop variety was Giza 101.

An area inside the experimental field was selected before entrance of the combine machine. To determine the pre-harvest losses inside the selected area, the seeds fell on the ground were collected and weighted directly. Then the seeds weight per the selected area is converted to be kg/fed (1 feddan = 4200 m²). However, pre-harvest loss is defined as the weight of seeds fallen on the ground or manual harvesting in specific area. Such losses were as a result of crop lodging and weather conditions (Hassan, 1999).

The sunflower heads from the selected area were cut manually and cleaned to remove foreign matters, dirt, broken and immature masses. Diameter of each head was measured with rule. However, the distance between two diagonally opposite edges of sunflower head was measured as head diameter (Sharmkumar (2006). The seeds from the heads were removed, counted and weighted. Based on net selected area yield, the seed yield was computed in kilograms per feddan. All of these data were averaged. These procedures were repeated at different days to represent different moisture content of the seeds.

To determine the average of moisture contents of the sunflower seeds, five samples from the removed seeds were elected randomly. The seeds were weighed and dried at 102 °C for 24 h in the oven and reweighed to accomplish moisture content on dry basis according to Ince *et al.* (2005). The corresponding pre-harvest losses, head diameter, number of seeds per head and seeds moisture content and yield are arranged in columns inside Excel spreadsheet for more analysis. The average of the tested sunflower properties is summarized in Table (1).

Table (1): Average plant properties of tested sunflower.

Item	Value
Plant length	185 ± 3 cm
Plant population	8 plant/m ²
Number of heads per plant	1
1000-seeds weight at seeds moisture content range of 7.2- 16 % db	49.5 ± 1.2 g
Sunflower head diameter at seeds moisture content range of 7.2- 16 % db	16.5 ± 1.8 cm
Mass of sunflower head at seeds moisture content range of 7.2- 16 % db	242.9 ± 89.5 g
Number of sunflower seeds per head at seeds moisture content range of 7.2- 16 % db	1232 ± 89 seed/head

Methods of crop yield prediction techniques

Multiple regression model

Multiple regression model (MLR) is to incorporate a number of independent variables simultaneously for predicting the value of a dependent (Abd El-Mohsen, 2013). The general form of the regression equation is as follows:

$$Y = b_0 + b_1X_1 + \dots + b_3X_3 + \dots + b_nX_n \dots \dots \dots (1)$$

Where Y is the dependent variable representing sunflower yield, b_0 is a constant, where the regression line intercepts the y-axis, $b_1 \dots b_n$ are regression coefficients, representing the amount of the dependent variable Y changes when the corresponding independent changes 1 unit and $X_1 - X_n$ are independent variables. MLR analysis was carried out using Excel spreadsheet to correlate the measured sunflower yield to four variables.

Adaptive neuro-fuzzy inference system

The architecture of the ANFIS is shown in Figure (1). The ANFIS consists of five layers including, the fuzzy layer, product layer, normalized layer, de-fuzzy layer and total output layer. For more information, Jang (1993) is referred. In the first layer (fuzzy layer), x_1 and x_2 are the inputs of adaptive nodes A_i and B_i , respectively. A_i and B_i are the linguistic labels used in the

fuzzy theory for describing the membership functions. The five layers of ANFIS model are as follows:

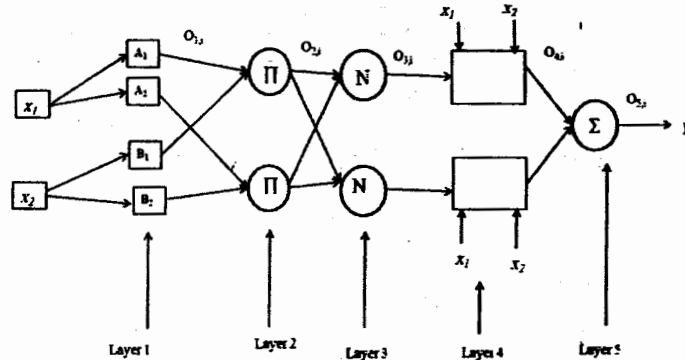

Figure (1): ANFIS architecture.

Layer1: (Input nodes): Each node output in this layer is fuzzified by membership grade of a fuzzy set corresponding to each input.

$$O_{i,1} = \mu_{A_i}(x_1) \quad i = 1,2 \quad \dots\dots\dots(2)$$

or

$$O_{i,1} = \mu_{B_j}(x_2) \quad j = 1,2 \quad \dots\dots\dots(3)$$

Where, x_1 and x_2 are the inputs to node i ($i = 1, 2$ for x_1 and $j = 1, 2$ for x_2) and x_1 (or x_2) is the input to the i^{th} node and A_i (or B_j) is a fuzzy label.

Layer 2 (Rule nodes): Each node output in this layer represents the firing strength of a rule, which performs fuzzy, AND operation. Each node in this layer, labelled Π , is a stable node which multiplies incoming signals and sends the product out.

$$O_{2,i} = W_i = \mu_{A_i}(x_1)\mu_{B_j}(x_2) \quad i = 1,2 \quad \dots\dots\dots(4)$$

Layer 3 (Average nodes): In this layer, the nodes calculate the ratio of the i^{th} rules firing strength to the sum of all rules firing strengths

$$O_{3,i} = \bar{W}_i = \frac{w_i}{w_1 + w_2} \quad i = 1,2 \quad \dots\dots\dots(5)$$

Layer 4 (Consequent nodes): In this layer, the contribution of i^{th} rules towards the total output or the model output and/or the function calculated as follows: Where, is the output of Layer 3 and a_i, b_i, q_i are the coefficients of linear combination in Sugeno inference system. These parameters of this layer are referred to as consequent parameters.

$$O_{4,i} = \bar{W}_i f_i = \bar{W}_i(a_i x_1 + b_i x_2 + q_i) \quad i = 1,2 \quad \dots\dots\dots(6)$$

Layer 5: (Output nodes): The node output in this layer is the overall output of the system, which is the summation of all coming signals

$$O_{s,i} = Y = \sum_1^2 \bar{W}_i f_i = \frac{\sum_1^2 \bar{W}_i f_i}{\sum_1^2 \bar{W}_i} \dots\dots\dots(7)$$

The Sugeno- type Fuzzy Inference System, (Takagi and Sugeno, 1985) which is the combination of a FIS and an Adaptive Neural Network, was used in this research for sunflower yield modeling. The optimization method used is hybrid learning algorithms. For a first-order Sugeno model, a common rule set with two fuzzy if-then rules is as follows:

Rule 1: If x_1 is A_1 and x_2 is B_1 , then $f_1=a_1x_1+b_1x_2+q_1$

Rule 2: If x_1 is A_2 and x_2 is B_2 , then $f_2=a_2x_1+b_2x_2+q_2$

where, x_1 and x_2 are the crisp inputs to the node and A_1, B_1, A_2, B_2 are fuzzy sets, a_i, b_i and q_i ($i = 1, 2$) are the coefficients of the first-order polynomial linear functions. Structure of a two-input first-order Sugeno fuzzy model with two rules is shown in Figure (1) and consists of five layers (Jang, 1993).

Adaptive neuro-fuzzy inference system for sunflower yield prediction

The fuzzy logic toolbox of MATLAB 7.11.0.584 (R2010b) was used for the modeling of the ANFIS in this research. To construct a fuzzy based predictive model, the obtained field data were divided into two different groups: training and testing. The training data matrix was composed of 27 data points. 5 data points, which are different from the training data, were used for the testing of the ANFIS model. There are no fixed rules for developing an ANFIS model (Yan *et al.*, 2010). The data used in developing MLR are the same for developing ANFIS model.

ANFIS model developed in this research has four inputs (HD-SN-MC-PH) and an output (Yield) as depicted in Figure (2) and Figure (3). For the determination of the best fit in the fuzzy model, types of membership function for input are changed. The four "trimf" (triangle) membership functions were the best for each input. The numerical range were used for HD (11-20.4 cm), for SN (851-1572), for MC (7.2-16%db), for PH (15-60.57kg/fed) and for seed yield (1425-1650 kg/fed).

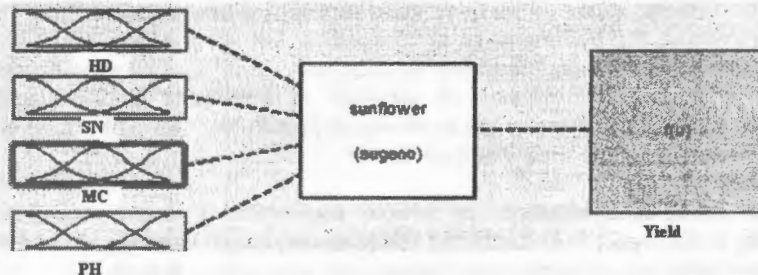

Figure (2): ANFIS model with four inputs and one output.

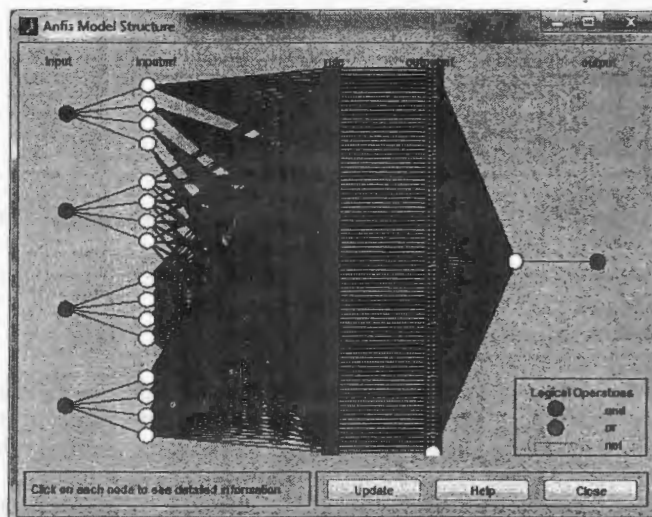

Figure (3): ANFIS model structure for sunflower yield prediction.

A hybrid learning algorithm was employed to train the ANFIS model. It combines the least-squares estimator and the gradient descent method. However, in the ANFIS training algorithm, each epoch is composed from a forward pass and a backward pass. In the forward pass, a training set of input patterns (an input vector) is presented to the ANFIS, neuron output is calculated on the layer-by-layer basis, and rule consequent parameters are identified. As soon as the rule consequent parameters are established, an actual network output vector, y_d , is computed and the error vector (e) is determined as ($e = y_d - y_n$) as y_n is actual output. This process finishes at desired epochs (Jang, 1993).

The number of the membership function is 4 for each input with four linguistic terms {low (L), medium (M), high (H), very high (VH)} and the total rules were 256 ($4 \times 4 \times 4 \times 4$). The membership function of the model is shown in Figure (4). Specifications of the developed ANFIS are illustrated in Table (2). Figure (5) shows the training error at 10 epochs. The error of the model was 0.0816 with type of the membership function was "trimf", output membership function is linear. The pattern of variation of measured and predicted sunflower yield for the training set is shown in Figure (6). The plot shows the coherence nature of the data distribution.

Simple correlation

All possible coefficients of simple correlation (r) were calculated according to Snedecor and Cochran (1980) among head diameter, number of seeds per head, moisture content of seeds and pre-harvest losses.

Models evaluation

The performance of the developed models is examined using some statistical measures that are well known in literature such as root mean square error (RMSE) and mean error (ME). ME has a unit and it is expressed as,

$$ME = \frac{\sum_{j=1}^n (Y_j - \hat{Y}_j)}{n} \dots\dots\dots(8)$$

Where, Y and \hat{Y} are the actual and predicted values, respectively and n is the number of observations. Root mean square error (RMSE) yields the residual error in terms of the mean square error expressed as,

$$RMSE = \sqrt{\frac{\sum_{j=1}^n (Y_j - \hat{Y}_j)^2}{n}} \dots\dots\dots(9)$$

Table (2): Specifications of the developed ANFIS.

Item	Value
Number of linear parameters	1280
Number of nonlinear parameters	48
Total number of parameters	1328
Decision method for fuzzy logic	Product
Output combination method (Defuzzification)	Weighted average
Type of membership function	Triangle
Number of fuzzy rules	256

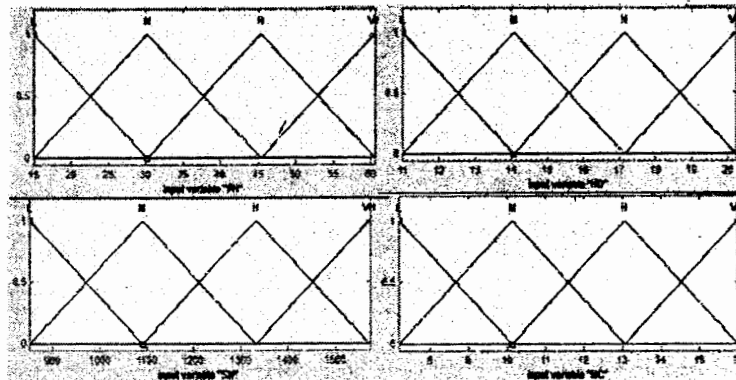

Figure (4): Membership function for input variables for yield ANFIS model.

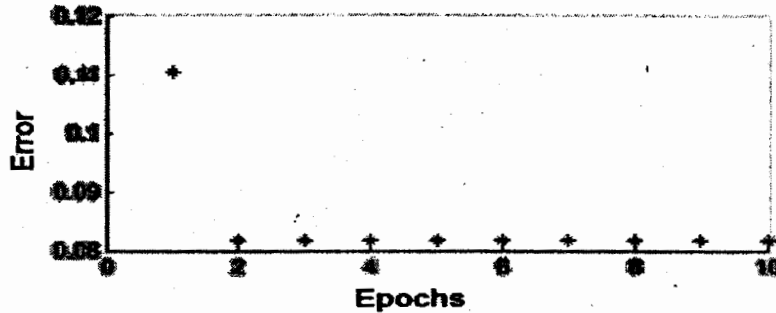

Figure (5): The training error at 10 epochs.

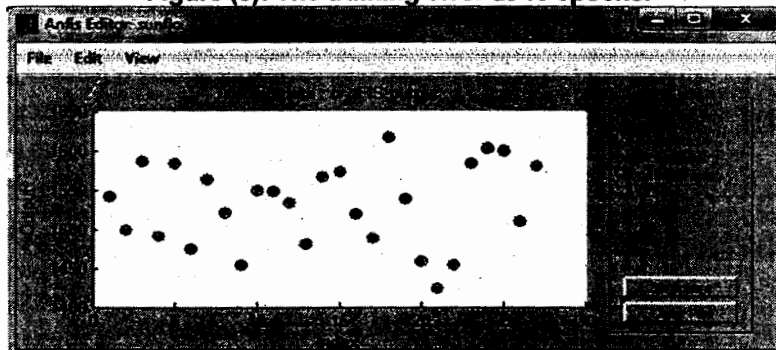

Figure (6): Online distribution of predicted and actual sunflower yield in training data.

RESULTS AND DISCUSSION

Correlation analysis

Analysis was made to evaluate the inter-relationships between the selecting related variables and sunflower yield. The simple correlation coefficients were determined for 4 variables and sunflower yield. Coefficients of correlation seed yield and affecting variables from whole data obtained are presented in Table (3).

The analysis shows that sunflower head diameter, number of seeds per head and moisture content of seeds were positive correlation with seed yield, $r = 0.533$, $r = 0.595$ and $r = 0.331$ (Table 3), respectively indicating dependency of seed yield of sunflower on these variables. Similar results were obtained by Singh *et al.* (1977). It was also found that the head diameter was positive correlation with seed yield of sunflower. Similar results were obtained in a study conducted previously by Saady and El-Metwally (2009). It was observed that the head diameter was positive correlation with seed yield of sunflower with $r = 0.633$. Sharnkumar (2006) revealed that the head diameter and number of seeds per head were positively correlated with yield with $r = 0.589$ and $r = 0.805$, respectively. Similar results were obtained by Patil *et al.* (1996).

Pre-harvest shows negative correlation with seed yield as illustrated in Table (3). The correlation of head diameter, number of seeds per head and moisture content of seeds was positive, suggesting that the higher of these variables the higher would be the yield. Results of Table (3) show that correlation of pre-harvest with yield was negative ($r = -0.317$) concluded that by increasing pre-harvest losses, the seed yield decreases. In conclusion, the highest seed yield was 1650 kg/fed which was observed at 20.4 cm head diameter, 1361 number of seeds per head, 16.2% seeds moisture content and 17.4 kg/fed for pre-harvest losses.

Table (3): The correlation coefficients among the seed yield of sunflower crop and related variables.

	Head diameter	No. of seeds per head	Moisture content of seeds	Pre-harvest losses
Head diameter	1			
No. of seeds per head	0.794	1		
Moisture content of seeds	0.253	0.127	1	
Pre-harvest losses	0.075	0.027	-0.475	1
Yield	0.533	0.595	0.331	-0.317

Multiple regression results

The regression of seed yield on related variables (head diameter, number of seeds per head, moisture content of seeds and pre-harvest losses) was performed and the created MLR model is given as:

$$\text{Yield (kg/fed)} = 1324.138 + 2.457 \cdot \text{HD} + 0.131 \cdot \text{SN} + 2.622 \cdot \text{MC} - 0.559 \cdot \text{PHL} \dots (10)$$

Where HD is head diameter (cm), SN is number of seeds per head, MC is moisture content of seeds (% db) and PH (kg/fed) is pre-harvest losses. The explanation coefficient in the MLR model was equal with $R^2 = 0.734$. Thus that nearly 73% of the yield changes by four variables of head diameter, number of seeds per head, moisture content of seeds and pre-harvest losses can be justified.

Adaptive neuro-fuzzy inference system

After training and testing ANFIS model, the results are compared with MLR model for the estimation of sunflower crop yield. The predicted error (ME) values were computed for each model. Prediction error in testing stage (Table 4) obtained from MLR model was 33.84 kg/fed and through ANFIS model, it was 18 kg/fed which was sufficiently small indicating that ANFIS model is best prediction model. The results from Table (4) also showed that the RMSE from the regression model was more than the ANFIS method. This means that the amount of error in the estimation by regression method was more than the error in ANFIS method thus can be stated that the ANFIS for predicting sunflower yield was more effective than regression approach.

Figure (6) shows that the plot correlation between measured values of sunflower crop yield and predicted values of sunflower crop yield from ANFIS and MLR models in training and testing stages. It is noticeable from Figure (6) that the predicted values from ANFIS are closer to the actual values than that from MLR. The values of coefficient of determination $R^2 = 0.996$ was

observed using ANFIS technique and when using MLR model, $R^2 = 0.702$, which clearly indicates that ANFIS model provides better estimation of yield in comparison to the regression analysis in the case of unknown test data sets.

Table (4): Comparison of error indicators for ANFIS versus MLR models during training and testing data sets in the prediction of yield.

	MLR	ANFIS	MLR	ANFIS
	Training		Testing	
ME (kg/fed)	19.70	.	33.84	18.00
RMSE (kg/fed)	27.49	.	41.94	19.58

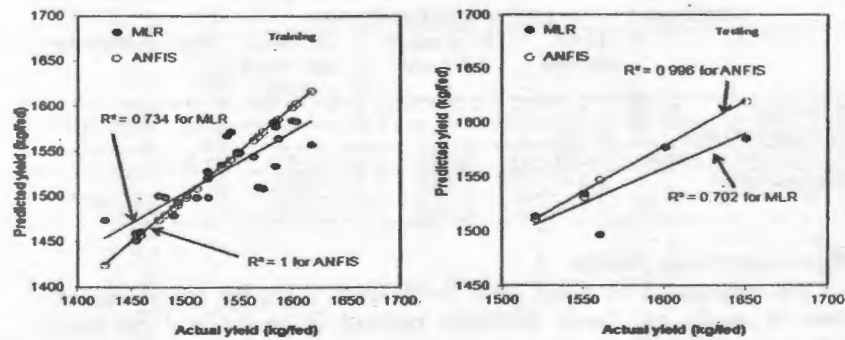

Figure (6): Correlation of predicted and actual data of yield during training and testing stages.

The surface plots of ANFIS model are shown in Figure (7). The figure presents the relationship between input variables and their contribution to the output variable. It provides a visual impression of the possible combinations of the two input variables and the output in a three-dimensional view. It is fast and visual method of showing the yield to the farm manager. Clearly, the surface is complex and highly nonlinear

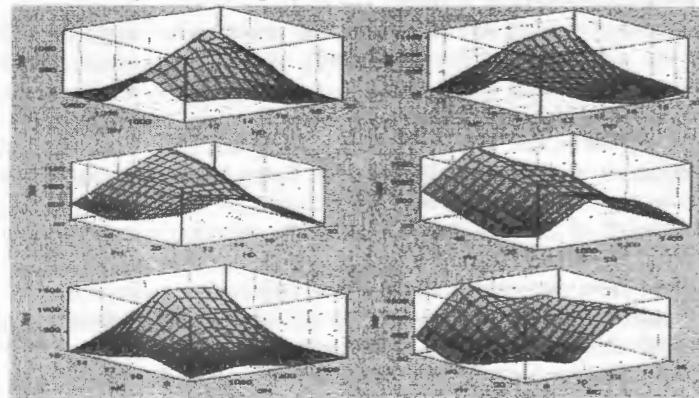

Figure (7): The surface plots of yield ANFIS model.

CONCLUSION

Sunflower head diameter, number of seeds per head and moisture content of seeds were positive correlation with seed yield and pre-harvest showed negative correlation with seed yield. The highest seed yield was 1650 kg/fed and this amount was observed at 20.4 cm head diameter, 1361 No. of seeds per head, 16.2% seeds moisture content and 17.4 kg/fed for pre-harvest losses. The overall results indicated that ANFIS provided higher accuracy for the prediction of sunflower seed yield than MLR. ANFIS is a valuable method for the determination of sunflower yield, because it combines the advantages of both neural network and fuzzy logic which offers good results.

REFERENCES

- Abd El-Mohsen, A. A. (2013). Correlation and regression analysis in barley. *World Essays Journal*, 1 (3): 88-100.
- Abd El-Mohsen, A. A., G. O. Mahmoud and S. A. Safina (2013). Agronomical evaluation of six soybean cultivars using correlation and regression analysis under different irrigation regime conditions. *Journal of Plant Breeding and Crop Science*, 5(5): 91-102.
- Abdel-Wahab, A.M., E.E Rhoden, C.K.Bonsi, M.A. Elashry, Sh.E. Megahed, T.Y. Baomy and M.A. El-Said (2005). Productivity of some sunflower hybrids grown on newly reclaimed sandy soils, as affected by irrigation regime and fertilization. *HELIA*, 28 (42):167-178.
- Abou-Hadid, A. F., M. A. A. Abdrabbo, A. A. Khalil and M. K. Hassanein (2010). Monitoring land-cover in the new reclaimed area: A case study in El-Nubaria, Egypt. *Nature and Science*, 8(12), 115-122.
- Aowad, M. M. and A. A. A. Mohamed (2009). The effect of bio, organic and mineral fertilization on productivity of sunflower seed and oil yields. *J. Agric. Res. Kafrelsheikh University*, 35 (4):1013-1028.
- Cook, S. (2008). Sunflowers - a growers guide. [WWW.WARWICK.AC.UK/GO/CLIMATECHANGE/INNOVATIONNET WORK](http://WWW.WARWICK.AC.UK/GO/CLIMATECHANGE/INNOVATIONNETWORK).
- Dourado-Neto, D., D. A. Teruel, K. Reichardt, D.R. Nielsen, J. A. Frizzone, and O.O.S. Bacchi (1998). Principles of crop modelling and simulation: modeling of root growth and other belowground processes, limitations of the models, and the future of modeling in agriculture. *Sci. agric., Piracicaba*, 55 (Número Especial):58-61.
- El-Marsafawy, S., M. (2006). Impact of climate change on sunflower crop production in Egypt. *The 2nd International Conf. on Water Resources & Arid Environment*:1-26.
- El-Saidy, A. E.A., S. Farouk and H.M. Abd El-Ghany (2011). Evaluation of different seed priming on seedling growth, yield and quality components in two sunflower (*Helianthus annuus L.*) cultivars. *Trends in Applied Sciences Research*, 6: 977-991.

- FAO (2010). Production Year Book. Food and Agricultural Organization of United Nation, Rome, Italy.
- France, J. and J.H.M. Thornley (1984). Mathematical models in agriculture. London: Butterworths.
- Fritz, T. (2008). Use ratio to minimize sunflower harvest loss. <http://articles.aberdeennews.com>.
- George, A. S. and A. G. Ioanna (2009). Fruit production forecasting by neuro-fuzzy techniques. 113th EAAE Seminar "A resilient European food industry and food chain in a challenging world", Chania, Crete, Greece, date as in: September 3 - 6, 2009:1-12.
- Graves, A. R., T. Hess, R. B. Matthews, W. Stephens, and T. Middleton (2002). Crop simulation models as tools in computer laboratory and classroom-based education. *J. Nat. Resour. Life Sci. Educ.*, 31:48-54.
- Griffin, G.A. (1976). Fundamentals of machine operations combine harvesting. *John Deere Service Publication*:134-156.
- Güven, C. I. and S. I. Sherif (2010). Egypt oilseeds and products annual. USDA Foreign Agricultural Service, Global Agricultural Information Network, http://gain.fas.usda.gov/Recent%20GAIN%20Publications/Oilseeds%20and%20Products%20Annual_Cairo_Egypt_5-3-2010.pdf:11p.
- Hamed, S.F., S. M. Wagdy, and M.G. Megahed (2012). Chemical characteristics and antioxidant capacity of Egyptian and Chinese sunflower seeds: A case study. *Life Sci J.*, 9(2):320-328.
- Hassan, M. M. K. (2008). Developing of local equipment for threshing and chopping sunflower. PhD. Thesis, Faculty of Agriculture, Agric. Eng. Dept., Mansoura University.
- Hassan, M.M. K. (1999). Evaluating of different methods of sunflower harvesting. Unpublished M.Sc. Thesis, Agric. Eng. Dept., Faculty of Agriculture, Zagazig University, 149p.
- Ibrahim, O.M. (2012). Simulation of barley grain yield using artificial neural networks and multiple linear regression models. *Egypt. J. of Appl. Sci.*, 27(1):1-11.
- Ince, A. S. Uğurluay, E. Güzel and M.T. Özcan (2005). Bending and shearing characteristics of sunflower stalk residue. *Biosystems Engineering*, 92(2):175-181.
- Jang, J.-S.R. (1993). ANFIS: Adaptive-network-based fuzzy inference systems. *IEEE Trans. on Systems, Man, and Cybernetics*, 23(3):665-685.
- Jayaram, M. A. and N. Marad (2013). Fuzzy inference systems for crop yield prediction. *Journal of Intelligent Systems*, 21(4):363-372.
- Krishna, R. and S. Prajneshu (2008). Neuro-fuzzy approach for modeling and forecasting: An application. *J. Ind. Soc. Agril. Statist.*, 62(3) : 214-220.
- Kumar, P. (2011). Crop yield forecasting by adaptive neuro fuzzy inference system. *Mathematical Theory and Modeling*, 1(3):1-7.
- Lin, W. C. and B. D. Hill (2008). Neural network modelling to predict weekly yields of sweet peppers in a commercial greenhouse. *Canadian Journal of Plant Science*, 88(3): 531-536.
- Ministry of Agriculture and Land Reclamation (1990). Sunflower particularities and cropping, pp. 41-44.

- Patil, B. R., M. Rudraradhya, C. H. M. Vijayakumar, H. Basappa and R. S. Kulkarni (1996). Correlation and path analysis in sunflower. *Journal of Oil Seeds, Research*, 13 (2):162-166.
- Qaddoum, K., E. L. Hines and D. D. Iliescu (2013). Yield prediction for tomato greenhouse using EFuNN. *ISRN Artificial Intelligence*, Volume 2013, Article ID 430986, 9 pages.
- Ruttan, V.W. (1983). Agricultural research policy issues. *Horticultural Science*, 8:809- 1983.
- Saudy, H. S. and I. M. El-Metwally (2009). Weed management under different patterns of sunflower-soybean intercropping. *Journal of Central European Agriculture*, 10 (1):41-52.
- Sharnkumar, B. (2006). Correlation studies between seed, seedling growth and yield characters on yield of sunflower hybrids (*Helianthus annuus* L.). M.Sc. Thesis, Dept. of Seed Science and Technology, College of agriculture, University of Agricultural Sciences, Dharwad, India.
- Singh, B., J.N. Sachan and D. Singh (1977). Variability and correlation in sunflower. *Pantonagar. Journal Research*, 2: 27-30.
- Snedecor, G. W. and G. W. Cochran (1980). *Statistical Methods*, 7th edition. The Iowa State University Press, Ames, Iowa.
- Stathakis, D., I. Savin and T. Negre (2006). Neuro-fuzzy modeling for crop yield prediction. *ISPRS Commission VII Mid-term Symposium "Remote Sensing: From Pixels to Processes"*, Enschede, the Netherlands, 8-11 May 2006: 358- 361.
- Takagi, T. and M. Sugeno (1985). Fuzzy identification of systems and its applications to modeling and control. *IEEE Trans. on Systems, Man, and Cybernetics*, 15: 116-132.
- Taki, M. and M. Haddad (2012). A novel method with multilayer feed-forward neural network for modeling output yield in agriculture. *International Journal of Modern Agriculture*, 1(1):13-23.
- Thongboonnak, K. and S. Sarapirome (2011). Integration of artificial neural network and geographic information system for agricultural yield prediction. *Suranaree J. Sci. Technol.*, 18(1):71-80.
- USDA (2008). Accessed on, 2009/07/25, [http:// www.nal. usda. gov/ fnic/ food comp/ cgibin/ list_nut_edit.pl](http://www.nal.usda.gov/fnic/foodcomp/cgi-bin/list_nut_edit.pl).
- Venugopalan, R. and Samasundaran, K.S. (2005). Statistical model for evolving crop-logging technique in banana. *Trop. Agril.*, 82: 23-27.
- Yan, H., Z. Zou and H. Wang (2010). Adaptive neuro fuzzy inference system for classification of water quality status. *Journal of Environmental Sciences*, 22(12):1891–1896.
- Zaefizadeh, M., M. Khayatnezhad and R. Gholamin (2011). Comparison of multiple linear regressions (MLR) and artificial neural network (ANN) in predicting the yield using its components in the Hulless barley. *American-Eurasian J. Agric. & Environ. Sci.*, 10 (1): 60-64.
- Zhang, J., Y. Wang, J. Li and P. Yang (2008). A neural network model for predicting cotton yields. *Computer And Computing Technologies In Agriculture*, Volume II The International Federation for Information Processing Volume 259:1321-1322.

التنبؤ بإنتاجية محصول عباد الشمس باستخدام تطبيق برنامج حاسب آلي عبد الواحد محمد أبو كريم^{1,2} و مملوح منياوي¹

¹ معهد بحوث الهندسة الزراعية، مركز البحوث الزراعية، وزارة الزراعة واستصلاح الأراضي
² كلية المجتمع بحريملاء، جامعة شقراء، المملكة العربية السعودية

يعتبر تقدير إنتاجية المحاصيل من الأمور الهامة للتنبؤ باحتياجات الأسواق والأنشطة المرتبطة بالزراعة ولتعزيز الإنتاجية، بالإضافة إلى أهمية هذا التقدير عند تطبيق نظم الزراعة والحصاد الآلية. إلا أنه لتقدير تلك الإنتاجية لابد من أخذ عينات كثيرة، وإجراء العديد من القياسات التي تتطلب وقت وجهد كبيرين. لذا اهتم هذا البحث بتطبيق برامج الحاسب الآلي متمثلة في منظومة استنتاج عصبية مشوشة مكيفة (ANFIS) والإرتداد الخطي المتعدد (MLR) للتنبؤ بإنتاجية محصول عباد الشمس المنزوع في منطقة النوبارية بمصر. حيث كانت مخلات برامج التنبؤ المستخدمة هي قطر قرص العباد، المحتوى الرطوبي للبذور، وعدد البذور في قرص العباد والفوائد الأولية قبل الحصاد، بينما كانت المخرجات هي الإنتاجية. وأوضحت النتائج أن منظومة ANFIS قادرة على التنبؤ الدقيق بإنتاجية محصول عباد الشمس تحت تأثير هذه المتغيرات الأربعة الداخلة للبرنامج. وبالمقارنة بنموذج التنبؤ باستخدام MLR، وجد أن منظومة ANFIS أفضل من نموذج MLR في التنبؤ بالإنتاجية، وقضح ذلك من خلال قيم معامل التحديد R^2 والذي سجلت قيمته 0.996. باستخدام منظومة ANFIS. وكان متوسط قيمة الخطأ بين القيم المتنبأ بها من خلال تطبيق منظومة ANFIS وقيم الإنتاج الفعلية هو 18 كجم/إدان.

قام بتحكيم البحث

كلية الزراعة - جامعة المنصورة

أ.د. على السيد أبو المجد

كلية الزراعة - جامعة الزقازيق

أ.د. / محمد محمد مراد