

## USING ELECTROSTATIC DISCHARGE FOR COATING SURFACE OF POLYETHYLENE FILM WITH CHITOSAN SUBSTANCE TO EXTEND THE CUCUMBER SHELF LIFE

Elsbaay, A. M.<sup>1</sup> and Elsebaie, E. M.<sup>2</sup>

### ABSTRACT

*This work focuses on, surface modification of polyethylene films by electrostatic discharge device and coating of chitosan on the surface of treated film. For this purpose, the surface of polyethylene film was treated by corona electrostatic discharge using different electrode gaps (0.5, 1 and 1.5 cm) and three levels of high voltage (5, 10 and 15 kV). Blown films of low density polyethylene having a thickness of 100  $\mu\text{m}$  and a density of 0.92  $\text{g}/\text{cm}^3$ . The cucumbers (*Cucumis sativus*) of Cucumbitaceae family was used. The modified polymeric film was immersed in a solution of chitosan 3 wt% for 3 hrs. Physical characterization and antimicrobial activity of chitosan/polyethylene film were evaluated and then it was used as an active package to extend shelf life of cucumber during storage at 4°C. The antimicrobial activity of chitosan/polyethylene composite was evaluated and then it was used as an active package to extend shelf life of cucumber during storage at 4°C. The surface modification of polyethylene films by electrostatic discharge machine (10 kV and 1 cm gap) and coating of chitosan substance was the best in the physical properties of other treatments. The obtained results showed that, chitosan/polyethylene composite film has high antimicrobial properties against *Listeria monocytogenes*, *Pseudomonase aeroginosa* and *Fusarium oxysporum*. Finally, the cucumber storage indicated that, cucumber rapped in chitosan/polyethylene composite have value of weight loss, pH and total aerobic bacteria count as well as yeast and*

---

<sup>1</sup> Assistant Professor Agricultural Engineering Department, Faculty of Agriculture, Kafrelsheikh University, Egypt. E-mail: [atef.ahmed@agr.kfs.edu.eg](mailto:atef.ahmed@agr.kfs.edu.eg)

<sup>2</sup> Lecturer, Department of food technology, faculty of agriculture, Kafrelsheikh University, Egypt.

*mold count lower than other samples (unwrapped and wrapped in native polyethylene).*

**Key words:** *Chitosan/polyethylene composite, Electrostatic discharge, LDP and Cucumbers.*

## 1. INTRODUCTION

Corona can be generated by a high DC potential or AC, in which case it can be sinusoidal or pulsed. Tesla coils, that generate dramatic corona discharge effects, operate at high frequencies of about 300 kHz. Corona has been found to be more intense at higher frequencies. Pulsed power is especially preferred for industrial applications. In the case of pulsed power discharges, the duty cycle of the waveform can be modified to alter the power consumption or the rate of ionization. Also the DC offset can be changed to vary the effects (Tishkoff *et al.*, 1996)

Surface modification and surface coating are the most applicable methods used for the fabrication of antimicrobial packaging films. Corona discharge is used in air purifiers to clean air by ionizing the air. Ozone is a by-product of corona discharge and it is used to kill microbes and neutralize airborne contaminants (Sanchez-Valdes *et al.*, 2009).

Electrostatic coating studies on food powders have shown better coating utilizing negative corona than utilizing the traditional method where coating depends mostly on gravity and the shaking action of the machine (Biehl and Barringer, 2004). When positive corona was used, a thicker layer of epoxy/polyester hybrid and greater improvement in adhesion for epoxy, nylon and diacon were observed (Dastoori, 2001). However, no work has been done on food powders on the advantages of positive corona.

Active packaging is an innovative area, which causes food products to have better sensorial features and extended shelf-life, thus ensuring enhanced food quality and safety (Soares *et al.*, 2009). There are several types of active packaging, including gas, moisture and UV absorbers, as well as flavor, antioxidant and antimicrobial releasers. One of the most modern active packaging systems is antibacterial packaging that is able to kill or inhibit the growth rate of microorganisms that contaminate foods. The antibacterial packaging films can be made by incorporation and

immobilization of antibacterial substances in packaging materials (Appendini and Hotchkiss, 2002). Several compounds have been employed as antibacterial agents in fabrication of antibacterial films. Among them, silver nanoparticles have widely been used as an antimicrobial agent (Chen *et al.*, 2013). Food coating/packaging is intended to provide some level of protection, prevent the transfer of materials from one food component to another, enhance the appearance of fruits and vegetables, and frequently contains other compounds to retard insects, microorganisms, oxidation and other intruders that would spoil the product (Brody, 2005). The Encyclopaedia Britannica defines surface coating as “any mixture of film-forming materials plus pigments, solvents, and other additives, which, when applied to a surface and cured or dried, yields a thin film that is functional and often decorative”. Many fresh and processed foods are packed in an inert or low oxygen atmosphere (by purging air with nitrogen or carbon dioxide). This procedure is known as modified atmosphere packaging (MAP) and can increase shelf-life four-fold, by inhibiting microbial growth and, consequently, food spoilage. In most circumstances, the packaging materials used are based on polymers, which, however, have their limitations. While materials such as glass and metals are impermeable to gases, plastics are semipermeable and undesirably affect food and drink quality over relatively short periods of time (e.g. carbon dioxide escape from carbonated drinks, oxygen ingress to packaged foods resulting in faster decay, and ethylene spread between fruits resulting in faster ripening). Plastics can be made more impermeable to gases through coatings or through the inclusion of nanoparticles within the polymer matrix (Robinson and Morrison, 2010). It is well known that chitosan is a biopolymer with good antimicrobial properties, because it inhibits the growth of a wide variety of fungi, pathogenic bacteria and spoilage microorganisms (Tsai *et al.*, 2002). The antimicrobial activity of chitosan depends on its molecular mass, the deacetylation degree and chemical degradation (Tokura *et al.*, 1997).

In addition, chitosan is readily soluble in various acidic solvents. From acidic solutions, 8 flexible, clear and tough films can be formed, with good oxygen barriers. 9,10 Polyethylene is the most frequently used

polymer film for packaging, as it offers the advantage of being inert.11 Low-density polyethylene is heat sealable, inert, odour free and shrinks when heated. It is a good moisture barrier, but has relatively high gas permeability, sensitivity to oils and poor odour resistance. It is less expensive than most films and is therefore widely used. Hence, chitosan coating of polyethylene represents a procedure that can lead to obtaining new materials with decreased gas permeability and, additionally, with antibacterial properties.

Cucumbers (*Cucumis sativus*) of *Cucumbitaceae* family are one of the famous vegetable consumed freshly and as processed food in Egypt. The fruits were harvested in immature stage based on the fruit size and skin color. They are used as salad, fresh slicing vegetable and pickling for daily diet (New Guyana Marketing Corporation, 2004). These fruits normally suffer high moisture losses, rotting, and change color quickly from green to yellow during storage. They are also bruised or injured under mechanical forces in case of improper handling which cause of short shelf-life and unmarketable quality after harvesting (Mikal, 2010). Thus, there is an urgent need to have alternative technologies to minimize the undesirable physicochemical and physiological changes of cucumbers during storage. Many techniques have been studied in order to extend the shelf life of fresh produces for example, low temperature and high relative humidity, controlled and modified atmosphere packaging, etc.

The objective of this study was manufacturing local electrostatic charge unit to improve the polyethylene quality as food packaging material by chitosan surface deposition using electrostatic discharge coating procedures. In addition, the antibacterial properties of the composite films against *Pseudomonase aeroginosa* as a model Gram-negative bacterium and *Listeria monocytogenes* as a model Gram-positive bacterium are determined. Finally, evaluation the effect of wrapping cucumber by chitosan/polyethylene composite films on its physic-chemical parameters during storage.

## **2. MATERIALS AND METHODS**

The experimental work was carried out through agricultural season 2014/2015 at faculty of Agriculture, Kafr Elsheikh University.

Electrostatic discharge apparatus manufactured and tested in Agricultural Engineering Department.

Blown films of low density polyethylene having a thickness of 100  $\mu\text{m}$  and a density of 0.92  $\text{g}/\text{cm}^3$  and cucumbers (*Cucumis sativus*) of *Cucumbitaceae* family were used. All microorganisms' strains *Listeria monocytogenes*, *Pseudomonase aeruginosa* and *Fusarium oxysporum* were kindly provided by the Plant Pathology Department during 2015. Also, nutrient agar medium (NAM) and potatoes dextrose agar (PDA) used in the microbial tests were purchased from Merck Co. Ltd. (Darmstadt, Germany). Low average molecular weight chitosan (CHT) with 20-300 cP viscosity in 1% acetic acid and 75-85% deacetylation degree and other applied reagents were purchased from the Sigma-Aldrich Chemical Company (St. Louis, Mo., USA).

**Activation of polyethylene films – corona treatment:**

All raw polyethylene plastics which were cut at the dimensions of  $40 \times 30 \times 0.01$  cm (L  $\times$  W  $\times$  H) were cleaned overnight by acetone to remove the oil and impurities on the surface. Corona treatment of polyethylene was carried out prior to chitosan deposition using manufactured Corona. The experimental set-up of the corona treatment system is given in Figure 1 and figure 2. The PE film was placed between two electrodes subjected to a potential difference. The treatment station applies electrical power to the material surface, through an air gap, via a pair of electrodes. One of the electrodes is connected to a high potential source, and the other one rolls at ground potential, which also supports the material. Only the side of the material facing the high potential electrode should show an increase in surface tension. Atmospheric air was chosen as gas and the following parameters were used: inter electrode distance of (0.5, 1 and 1.5cm) and a high voltage (5, 10 and 15 kV). After the corona discharge pre-treatment, the polyethylene surface was enriched with oxygen-containing functionalities, which would assure good adhesion, as demonstrated below.

**Coating procedures:**

Chitosan coating onto the PE surface was achieved by Film dipping/immersion into chitosan solutions 3 wt% for 3 hrs. After that

LDP was removed and placed in a circular oven (controlled at 100°C) for 20 minutes (Wu *et al.*, 2012).

**Characterization tests:**

Electrical discharge treatment of LDPE films was carried out in the air at atmospheric pressure using a local manufactured device. An image of the electrostatic apparatus shown in Figure 1. The schematic of the high voltage power supply shown in Figure 2.

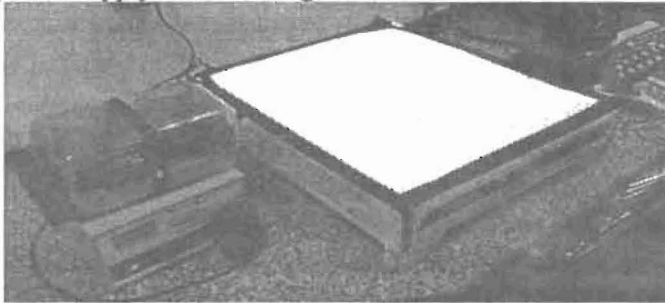

Fig. 1: An image of the electrostatic apparatus.

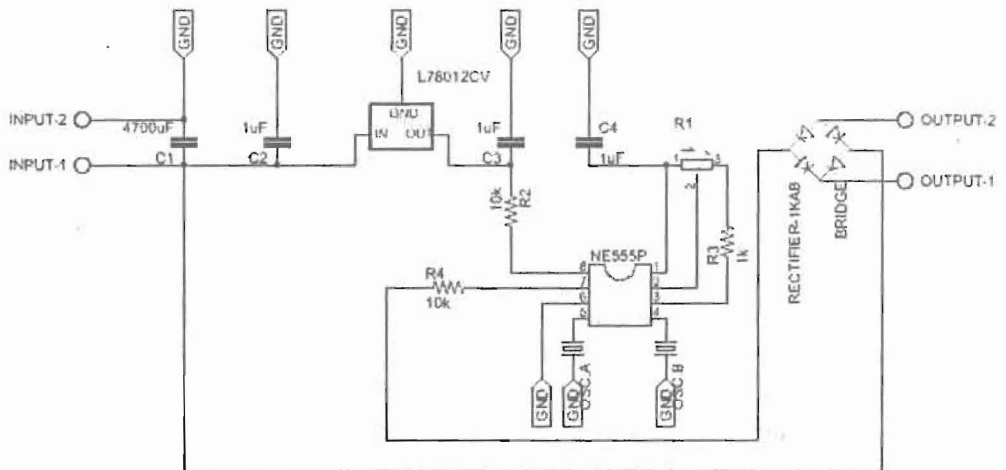

Fig. 2: The schematic of the high voltage power supply (local manufactured).

Corona discharge is highly dependent on geometry. Electric field intensity is higher around the surface of a charged conductor with higher curvature or lower radii of curvature. If  $Q$  is the total charge stored in a conductor and  $r$  is its radius of curvature, the electric field intensity  $E$  is

inversely proportional to the radius, as given by the following equation, where  $\epsilon_0$  is the permittivity of free space (and air) and is equal to  $8.852 \times 10^{-12}$  F/m and  $d$  is the distance between conductors, m.

$$E = \frac{Q}{4 \pi \epsilon_0 r^2} \dots\dots\dots (1)$$

$$V = Ed = \frac{Q}{A \epsilon_0} d \dots\dots\dots (2)$$

Therefore, as  $r$  decreases, the intensity of the electric field increases. This is why lightning conductors are made sharper and why antennas have to be protected from corona discharge.

The experimental study carried out at normal atmospheric (1 atm). The set up was a flat shaped positive electrode, whose gape between electrode and diode, a flat disk could be varied from 0.5 to 1.5 cm. The corona was detected by optical means. At 1 atm pressure, the pulse was in the form of and frequency of 1.2 kHz. The peak amplitude was 9 kV. The maximum possible current flow and power consumed during maximum current flow (Panicker, 2003).

$$I = \frac{V_{max}}{R} \dots\dots\dots (3)$$

$$P = I^2 R \dots\dots\dots (4)$$

Stress-strain curves using Zwick tensile testing machine 2010TH2A the load cell used mass 1kN. The test standard was ASTM D882-90.

Systematic studies to analyses the effect of processing variables on the as-moulded shrinkage were more recently conducted e.g. by (Chang and Faison, 2001). All these studies concluded that the holding pressure and the injection temperature are the most important process variables affecting shrinkage. The shrinkage varies in the space and it is usually quoted at room temperature just after the part has been ejected from the mould (Pontes, 2002):

$$Sh_i = \frac{D_{imp} - D_{part}}{D_{imp}} \dots\dots\dots (5)$$

Where:  $D_{imp}$  is the dimension in the impression in the  $i$  direction and  $D_{part}$  is the corresponding part dimension. According to this definition the

shrinkage is positive when the part undergoes a negative strain, i.e. the following relationship applies

$$Sh_i = - \varepsilon_{ii}^{obs} \dots \dots \dots (6)$$

Where:  $\varepsilon_{ii}^{obs}$  is the measured strain in the  $i$  direction.

Optical characteristic of polyethylene was measurement by UH4 150 spectrophotometer according the following equations (JIS K7375, 2012):

$$T_t = \frac{T_2}{2T_1 - T_3 - (T_1 - T_3) \left(1 - \frac{\rho_r}{100}\right)} \times 100 \dots \dots \dots (7)$$

$$\rho_r = \frac{T_4}{T_1 - (T_1 - T_3) \left(1 - \frac{T_2}{T_1}\right)} \times 100 \dots \dots \dots (8)$$

Where:

- $T_t$  is the total light transmittance, %
- $P_t$  is the total light reflectance, %
- $T_1$  is the standard incident light intensity
- $T_2$  is the transmitted light intensity of the sample
- $T_3$  is the intensity of the incident light entering the light trap
- $T_4$  is the reflected light intensity of the sample

**Antimicrobial test:**

Antimicrobial efficiency of the chitosan/polyethylene composite films against *Listeria monocytogenes* and *Pseudomonase aeruginosa* was carried out by agar diffusion method as described by Sadeghnejad *et al* (2014). The agar diffusion method was performed using nutrient agar medium in case of bacteria or potatoes dextrose agar in case of fungi. The test was initiated by pouring the media onto sterilized Petri dishes and was allowed to solidify. 100  $\mu$ L of incubated testing microbial solution ( $10^8$  CFU/mL) was spread uniformly over the plate. Each film sample of 1.5 cm  $\times$  1.5 cm in size was placed on the medium surface. The Petri dishes were incubated for 1 day at 37  $^{\circ}$ C. The clear zone formed around the samples was recorded as an indication of inhibition of the microbial species. Control experiments were performed with uncoated.



**Storage experiment:**

Cucumber was selected for uniformity, shape, colour, and size, and any blemished or diseased fruits were discarded. The fruits ( $\approx 35$  g) were randomly distributed into three groups the first one was without rapping, second one rapped with native polyethylene and the last one rapped with modified polyethylene at  $4^{\circ}\text{C}$  for twenty one day. The sample tested every three days. Weight loss, pH value, titratable acidity, total microbial count, yeast and moulds count were determined by methods described in AOAC (2000).

**Statistical Analysis:**

Each experiment was replicated thrice and each parameter was analyzed in duplicate. The data recorded were analyzed using SPSS version 17.0 (SPSS, Chicago, III, and U.S.A). Two way analysis of variance was applied and the data were tabulated. The level of significant effects were tested by comparing mean values using the least significant difference (LSD) test at 1% level (Snedecor and Cochran, 1967).

**3. RESULTS AND DISCUSSION**

**Power consumption:**

The power consumption and the electrical current were direct proportion to the voltage as shown in figure 3. The power consumptions were 63, 250 and 563 watt at 5000, 10000 and 15000 V respectively.

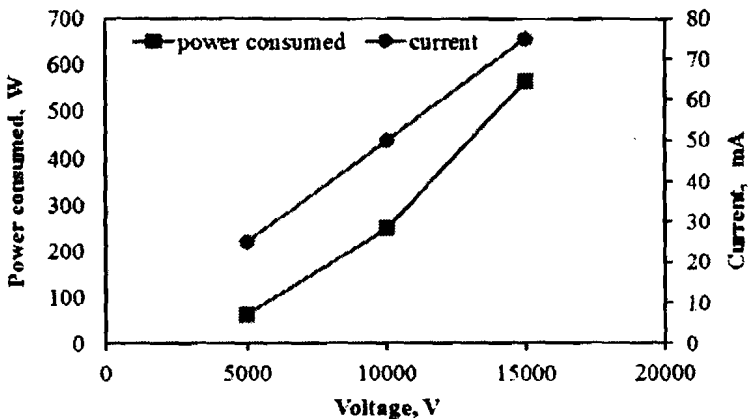

Fig. 3: shows the power consumption and electrical current for high voltage levels.

**Electrical field intensity:**

The electrical field intensity was direct proportion to the voltage and electrode gap as shown in figure 4. At the gap 0.5 cm, the electrical field intensity values were 1000, 2000 and 3000  $\text{kV.m}^{-1}$  for 5000, 10000 and 15000 V high voltage respectively. At the gap 1 cm, the electrical field intensity were 500, 1000 and 1500  $\text{kV.m}^{-1}$  for 5000, 10000 and 15000 V high voltage respectively. Also, electrical field intensity values at the gap 1.5 cm were 333.3, 666.7 and 1000  $\text{kV.m}^{-1}$  for 5000, 10000 and 15000 V high voltages respectively.

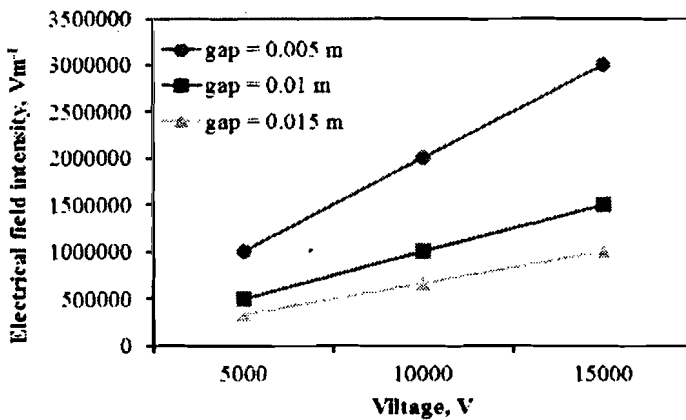

Fig. 4: shows the electrical field intensity at high voltage 5000, 10000 and 15000 V for electrode gap 0.5, 1 and 1.5 cm.

Figure 5 shows that the total charge stored in conductor with direct proportion to the voltage and electrode gap. At the high voltage 5000 V, the total charge stored in conductors were 0.797, 0.398 and 0.266  $\mu\text{C}$  for 0.5, 1 and 1.5 cm electrode gap respectively. At the high voltage 10000 V, the total charge stored in conductors were 1.59, 0.797 and 0.531  $\mu\text{C}$  for 0.5, 1 and 1.5 cm electrode gap respectively. Also, at the high voltage 15000 V, the total charge stored in conductors were 2.39, 1.95 and 0.797  $\mu\text{C}$  for 0.5, 1 and 1.5 cm electrode gap respectively.

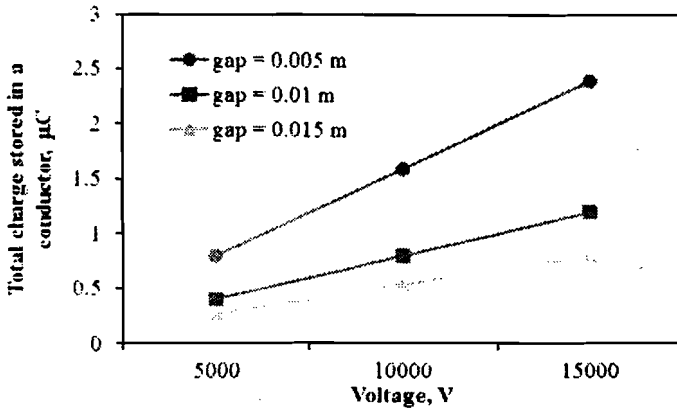

Fig. 5: shows total charge stored in conductor at high voltage 5000, 10000 and 15000 V for electrode gap 0.5, 1 and 1.5 cm.

**Mechanical properties of LDPE:**

Figure 6 presents the LDPE tensile strength under different condition of high voltage and the gap between the two electrodes device. At the gap 0.5 cm, the tensile strength were  $1.16 \times 10^7$ ,  $1.17 \times 10^7$  and  $1.16 \times 10^7$  Pa for 5, 10 and 15 kV high voltage respectively. At the gap 1 cm, the tensile strength were  $1.14 \times 10^7$ ,  $1.15 \times 10^7$  and  $1.17 \times 10^7$  Pa for 5, 10 and 15 kV high voltage respectively.

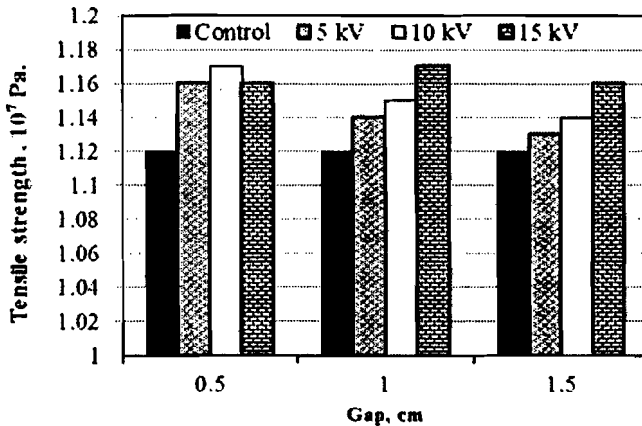

Fig. 6: LDPE tensile strength at high voltage 5, 10 and 15 kV for electrode gap 0.5, 1 and 1.5 cm.

While the tensile strength values at the gap 1.5 cm were  $1.13 \times 10^7$ ,  $1.14 \times 10^7$  and  $1.16 \times 10^7$  Pa for 5, 10 and 15 kV high voltage respectively. The high voltage 5 kV and the gap 0.5 cm were selected for completing the research because that operating condition give the highest value of tensile strength and low value of power consumption.

Data given in Table (1) show that, physical properties of modified low density polyethylene films were higher than native these may be due to accumulation of chitosan in a thin layer on the surface of low density polyethylene.

Table (1): Physical properties of native and surface modified low density polyethylene films

Type of low density polyethylene	Physical properties			
	Thickness ( $\mu$ m)	Shrinkage (%)	Transmit lightness	Tensile strength ( $\times 10^7$ Pa)
Native	100 <sup>b</sup>	76.3 <sup>b</sup>	93.7 <sup>a</sup>	1.12 <sup>b</sup>
Modified by chitosan	130 <sup>a</sup>	79.0 <sup>a</sup>	90.8 <sup>b</sup>	1.17 <sup>a</sup>

Means with different superscripts letters in the same column differ significantly (P < 0.01).

**Antimicrobial activity:**

Modified low density polyethylene by chitosan possessed noticeable inhibitory against *Listeria monocytogenes*, *Pseudomonase aeroginosa* and activity against fungi (*Fusarium oxysporum*). From date given in Table (2) it is clear that, Modified low density polyethylene by chitosan gave the highest wide inhibition zones (6.14mm), followed by that of native polyethylene.

Generally, all tested of modified low density polyethylene by chitosan showed effective antimicrobial activity against gram positive bacteria higher than that of gram negative bacteria(*Pseudomonase aeroginosa*).

Table (2): Antimicrobial activity of native and surface modified low density polyethylene films

Type of low density polyethylene	Inhibition zone (mm)		
	<i>Listeria monocytogenes</i> (G <sup>+</sup> )	<i>Pseudomonase aeroginosa</i> (G)	<i>Fusarium oxysporum</i>
Native	0.00 <sup>Ab</sup>	0.00 <sup>Ab</sup>	0.00 <sup>Aa</sup>
Modified by chitosan	5.38 <sup>Aa</sup>	4.57 <sup>Ba</sup>	2.64 <sup>Ca</sup>

Means with different superscripts (capital letters in the same row and small letters in the same column) differ significantly ( $P < 0.01$ ).

**Weight loss:**

Water is the most abundant nutrient in fruits. However, maximum amount of water content varies between individual fruit of same types because of structural difference. It may be also affected by cultural conditions, which influence structural differentiation (Salunkhe *et al.*, 1991). Weight is considered one of great important properties because it can cause fruit shriveling and advance senescence. It is mostly depends on relative humidity surrounding the fruit, but can also be associated with a slight reduction in flesh firmness (Ishaq *et al.*, 2009).

Table (3): Effect of wrapping with untreated and treated of polyethylene sheets on cucumber weight lose% during storage period at 4°C.

Storage period (day) at 4°C	Control		Wrapped with untreated polyethylene coated with chitosan 3%
	Unwrapped	wrapped with untreated polyethylene	
0	0.00 <sup>Ab</sup>	0.00 <sup>Ac</sup>	0.00 <sup>Ad</sup>
7	7.27 <sup>Aa</sup>	6.01 <sup>Bb</sup>	4.76 <sup>Cc</sup>
14	-	10.43 <sup>Aa</sup>	6.95 <sup>Bb</sup>
21	-	-	9.04 <sup>Aa</sup>

Means with different superscripts (capital letters in the same row and small letters in the same column) differ significantly ( $P < 0.01$ ).

Table (3) shown that, unwrapped samples had the highest weight loss during storage, followed by samples wrapped with native polyethylene, while the lowest weight loss was detected in case of samples wrapped with modified polyethylene. Plastic film materials are known to reduce water loss during prolonging storage. The reduction in water loss observed in the polyethylene bags plays a key role by serving as a tight barrier to water evaporation. This explains why samples kept unwrapped lost high amount of water because they offered less resistance to water loss.

It should be also noticed from the same table that, weight loss was ranged in unwrapped samples from 0.00 to 7.27 %; samples wrapped by native polyethylene, from 0.00 to 10.43% and samples wrapped by modified polyethylene from 0.00 to 9.04%.

**pH value :**

As shown in Table (4), pH value was increased in cucumber fruits from 5.36 at zero time to 5.99, 6.44 and 5.91 at the end of experiment in in case of unwrapped cucumber, cucumber wrapped with native polyethylene sheets and the third ones were wrapped with modified polyethylene sheets, respectively. *Ayala-Zavala et al. (2007)* reported that pH values increased during storage period in cucumber fruit. The increase in pH values seems to be normal during the postharvest life of cucumber fruit.

Table (4): Effect of wrapping with untreated and treated of polyethylene sheets on pH values in cucumber during storage period at 4°C.

Storage period (day) at 4°C	Control		Wrapped with untreated polyethylene coated with chitosan 3%
	Unwrapped	wrapped with untreated polyethylene	
0	5.36 <sup>Ab</sup>	5.36 <sup>Ac</sup>	5.36 <sup>Ad</sup>
7	5.99 <sup>Aa</sup>	5.91 <sup>Bb</sup>	5.56 <sup>Cc</sup>
14	-	6.44 <sup>Aa</sup>	5.79 <sup>Bb</sup>
21	-	-	5.91 <sup>Aa</sup>

Means with different superscripts (capital letters in the same row and small letters in the same column) differ significantly (P < 0.01).

**Titrateable acidity:**

Titrateable acidity is an important factor in maintaining the quality of some fruits and vegetables, which is directly related to the concentration of organic acids present in these products. Organic acids exist as free acids, anions (malate) or combined as salt (potassium bitartate) and esters such as isopentyle acetate (*Kays, 1991*).

Data in Table (5) showed that, titrateable acidity content decreased significantly during storage for all investigated samples.

Table (5): Effect of wrapping with untreated and treated of polyethylene sheets on titratable acidity values in cucumber during storage period at 4°C.

Storage period (day) at 4°C	Control		Wrapped with untreated polyethylene coated with chitosan 3%
	Unwrapped	wrapped with untreated polyethylene	
0	1.07 <sup>Aa</sup>	1.07 <sup>Aa</sup>	1.07 <sup>Aa</sup>
7	0.84 <sup>Cb</sup>	0.89 <sup>Bb</sup>	0.97 <sup>Ab</sup>
14	-	0.78 <sup>Bc</sup>	0.89 <sup>Ac</sup>
21	-	-	0.71 <sup>Ad</sup>

Means with different superscripts (capital letters in the same row and small letters in the same column) differ significantly (P < 0.01).

As shown in Table (5), titratable acidity was reduced in treated samples from 1.07 to 0.84%, 0.78% and 0.71 at the end of storage period for the follow cucumber samples (unwrapped samples and samples wrapped with native polyethylene sheets and modified polyethylene sheets), respectively. These results were in the same line with those found **Ghasemnezhad *et al.* (2010)**.

#### Total aerobic bacteria

Data tabulated in Table (6) shown that, aerobic plate count increased significantly during storage for all investigated samples, the recorded results were in the same line with those reported by **Ruiz-Cruz *et al.* (2010)**.

Data in Table (6) shown that, aerobic plate count was increased in cucumber from 3.82 log CFU/g to 4.23 , 5.69 and 4.48 log CFU/g at the end of experiment period in case of unwrapped cucumber, cucumber wrapped with native polyethylene sheets and the third ones were wrapped with modified polyethylene sheets, respectively. These results were in the same line with those of **Ediriweera *et al.* (2014)**.

Table (6): Effect of wrapping with untreated and treated of polyethylene sheets on aerobic plate count (log CFU/g) cucumber during storage period at 4°C.

Storage period (day) at 4°C	Control		Wrapped with untreated polyethylene coated with chitosan 3%
	Unwrapped	wrapped with untreated polyethylene	
0	3.82 <sup>Ab</sup>	3.82 <sup>Ac</sup>	3.82 <sup>Ad</sup>
7	4.23 <sup>Aa</sup>	4.10 <sup>Bb</sup>	4.01 <sup>Cc</sup>
14	-	5.69 <sup>Aa</sup>	4.23 <sup>Bb</sup>
21	-	-	4.48 <sup>Aa</sup>

Means with different superscripts (capital letters in the same row and small letters in the same column) differ significantly ( $P < 0.01$ ).

**Mould and yeast count:**

From data given in Table (7), it could be noticed that, moulds and yeasts count increased significantly during storage for all investigated samples. The received results were in the same line with those reported by Ruiz-Cruz *et al.* (2010).

Table (7): Effect of wrapping with untreated and treated of polyethylene sheets on moulds and yeasts count (log CFU/g) cucumber during storage period at 4°C.

Storage period (day) at 4°C	Control		Wrapped with untreated polyethylene coated with chitosan 3%
	Unwrapped	wrapped with untreated polyethylene	
0	4.18 <sup>Ab</sup>	4.18 <sup>Ac</sup>	4.18 <sup>Ad</sup>
7	5.07 <sup>Aa</sup>	4.77 <sup>Bb</sup>	4.38 <sup>Cc</sup>
14	-	5.18 <sup>Aa</sup>	4.52 <sup>Bb</sup>
21	-	-	4.73 <sup>Aa</sup>

Means with different superscripts (capital letters in the same row and small letters in the same column) differ significantly ( $P < 0.01$ ).

The results in the same table show that, moulds and yeasts count was increased in cucumber from 4.18log CFU/g to 5.07, 5.18 and 4.73 log CFU/g at the end of experiment period in case of unwrapped cucumber,



cucumber wrapped with native polyethylene sheets and the third ones were wrapped with modified polyethylene sheets, respectively.

### CONCLUSIONS

1. Electrostatic discharge was used to modify the surface of polypropylene. Oxygen-containing functional groups, including -OH and C=O, have been substantially formed and they can provide better enhancement on the adhesion of chitosan on the LDP substrate.
- 2- Chitosan/polyethylene film has high antimicrobial properties so using it increased cucumber shelf life during storage at 4C.

### 4. REFERENCES

- AOAC (Association of Official Analytical Chemists). (2000). Official Methods Of Analysis.; 17<sup>th</sup> Ed. Washington, D.C., USA.
- Appendini, P. and Hotchkiss, J. H. (2002). Review of antimicrobial food packaging. *Innovative Food Science & Emerging Technologies*, 3(2), 113-126.
- Ayala-Zavala, J. F., Wang, S. Y., Wang, C. Y., & González-Aguilar, G. A. (2007). High oxygen treatment increases antioxidant capacity and postharvest life of strawberry fruit. *Food Technology and Biotechnology*, 45(2), 166.
- Biehl, H. L. and Barringer, S. A. (2004). Comparison of the effect of powder properties on coating transfer efficiency and dustiness in two non-electrostatic and electrostatic systems, *Innov. Food Sci. Emerg. Technol.* 5: 191–198.
- Brody, A. L. (2005). Edible packaging. *Food Tech.* 56, 65.
- Chang, T. C., Faison, E. (2001). III – Shrinkage behavior and optimization of injection molded parts studied by the Taguchi Method. *Polym. Eng. Sci.* vol. 41: p. 703-710.
- Chen, Y. H., Hsu, C. C., & He, J. L. (2013). Antibacterial silver coating on poly (ethylene terephthalate) fabric by using high power impulse magnetron sputtering. *Surface and Coatings Technology*, 232, 868-875.
- Dastoori, K.; Makin, B. and Telford, J. (2001). Measurements of thickness and adhesive properties of electrostatic powder coatings for standard and modified powder coating guns, *J. Electrostat.* 51–52: 545–551.

- Ediriweera, S.; Abeywickrama, K.; Latifah, M.; Othaman, F.; Wan Hussin, R. & Tham, S.(2014). Quality of minimally processed, modified atmosphere stored bell pepper, as affected by pretreatment. *Tropical Agricultural Research and Extension*.16(2).
- Ghasemnezhad, M.; Shiri, M. A. & Sanavi, M.(2010). Effect of chitosan coatings on some quality indices of apricot (*Prunus armeniaca L.*) during cold storage. *Caspian Journal Environment Science*. 8 (1) : 25-33
- Ishaq, S.; Rathore, H.A.; Majeed, S.; Awan, S.and. Zulfiqar-Ali-Shah, S. (2009). The Studies on the physico-chemical and organoleptic characteristics of apricot (*Prunus armeniaca L.*) produced in Rawalakot, Azad Jammu and Kashmir during storage. *Pakistan Journal of Nutrition*. 8(6):856-860.
- JIS K7375 (2012). Plastics: Determination of total luminous transmittance and reflectance. Japanese Standards Association,The Japan Plastics Industry Federation.
- Kays, S. J. (1991). Post Harvest Physiology of Perishable Plant Products. *Vas Nostrand Rein Hold Book*, AVI publishing Co., pp: 149-316.
- Mikal, E. S. (2010). Cucumber. Department of vegetable crops, Mann lab. University of California, California. (Retrieved on October 2, 2011. From; [www.ba.ars.usda.gov/hb66/057\\_cucumber.pdf](http://www.ba.ars.usda.gov/hb66/057_cucumber.pdf).)
- New Guyana Marketing Corportion (NGMC). (2004). Cucumber postharvest care and Market preparation. Postharvest handling technical bulletin, No. 28. 2-11.
- Panicker, P. K. (2003). Ionization of air by corona discharge. MSc. in Aerospace Engineering, Texas University, Arlington.
- Pontes, A. J. V. (2002). Shrinkage and ejection forces in injection moulded products. Tese submetida à Universidade do Minho para obtenção do grau de Doutor em Ciência e Engenharia de Polímeros. Universidade do Minho.
- Robinson, D. K. R. and Morrison, M. J. (2010). Nanotechnologies for food packaging: Reporting the science and technology research trends, Report for the Observatory NANO, August 2010, [www.observatorynano.eu](http://www.observatorynano.eu).

- Ruiz-Cruz, S.; Alvarez-Parrilla, E.; de la Rosa, L. A.; Martinez-Gonzalez, A. I.; Ornelas-Paz, J. J.; Mendoza-Wilson, A. M. & Gonzalez-Aguilar, G. A. (2010). Effect of different sanitizers on microbial, sensory and nutritional quality of fresh-cut jalapeno peppers. *American Journal of Agriculture and Biological Sciences*, 5(3): 331-341.
- Sadeghnejad, A., Aroujalian, A., Raisi, A., and Fazel, S. (2014). Antibacterial nano silver coating on the surface of polyethylene films using corona discharge. *Surface and Coatings Technology*, 245: 1-8.
- Salunkhe, D. K.; Boun, H. R. & Reddy, N. R. (1991). Storage, processing and nutritional quality of fruits and vegetables. CRC Press Inc., Boston, MA, USA
- Sanchez-Valdes, S.; Ortega-Ortiz, H.; Ramos-de Valle, L.F.; Medellin-Rodriguez, F.J. and Guedea-Miranda, R. (2009). *J. Appl. Polym. Sci.* 953–962.
- Snedecor, G. W. & Cochran, W. G. (1967). *Statistical methods*. 6<sup>th</sup> Ed. New Delhi: Oxford and IBH publishing Co.
- Soares, F., Pires, A.C.S., Camilloto, G.P., Santiago-Silva, P., Espitia, P.J.P. & Silva, W.A. (2009) Recent patents on active packaging for food application. *Recent patents on food, nutrition & agriculture*, 1, 171-178.
- Tishkoff, J. M.; J. P. Drummon; T. Edwards and A. S. Nejad (1996). *Future Directions of Supersonic Combustion Research: Air Force/ NASA Workshop on Supersonic Combustion*. Newport News, Virginia.
- Tokura, S., Ueno, K., Miyazaki, S., & Nishi, N. (1996). Molecular weight dependent antimicrobial activity by chitosan. In *New Macromolecular Architecture and Functions* (pp. 199-207). Springer Berlin Heidelberg.
- Tsai, G. J.; Su, W. H.; Chen, H. C. and Pan, C. L. (2002). Antimicrobial activity of shrimp chitin and chitosan from different treatments and applications of fishpreservation. *Fisheries Sci*, 68(1): 170-177.

Wu, J. J., Lee, G. J., Chen, Y. S., & Hu, T. L. (2012). The synthesis of chitosan/polypropylene plastics for antibacterial application. *Current Applied Physics*, 12: 89-95.

### الملخص العربي

استخدام الشحن الاستاتيكي لتغطية سطح البولي ايثيلين بمادة الشيتوزان لزيادة العمر التخزيني للخيار

عاطف محمد السباعي \* ، عصام محمد السباعي \*\*

تناولت هذه الدراسة استخدام الشحن الالكتروستاتيكي في تعديل سطح البولي ايثيلين وكذلك إضافة مادة الشيتوزان وذلك بهدف تكوين عبوات يمكن من خلالها اطالة العمر التخزيني للخيار. وللوصول الي هذا الغرض تم تصنيع وحدة الشحن الالكتروستاتيكي محليا والتي تتكون من وحدة لرفع الجهد للوصول الي الجهد العالي المطلوب والكثود الموجب والسالب. وكانت المسافة بين الالكثود الموجب والسالب (١٠،٥ و ١،٥ سم) وتم استخدام ثلاث مستويات من الجهد العالي (٥، ١٠، ١٥ كيلوفولت). والبولي ايثيلين المستخدم في الدراسة سمكه ١٠٠ ميكرومتر وكثافته ٠.٩٢ جم/سم<sup>٣</sup>. وتم معاملة هذه الاسطح المعدلة بمحلول من الشيتوزان ٣ % علي اساس وزني. وقد تم تقييم الخواص الفيزيائية للبولي ايثيلين المغطي بمادة الشيتوزان (قوة الشد - نفاذية الضوء - الانكماش) وتم ايضا تقييم خواص التضاد الميكروبي لهذه الاغلفة المعدلة والمغطاة بالشيتوزان واستخدامها كمواد تعبئة نقطة بغرض اطالة العمر التخزيني للخيار المحفوظ على ٤ درجة مئوية ومن اهم النتائج المتحصل عليها ما يلي

- ١- اظهرت التجارب ان البولي ايثيلين المعدل الكتروستاتيكي عند جهد عالي ١٠ كيلوفولت ومسافة بين الالكثود الموجب والسالب ١ سم والمغطي بمادة الشيتوزان افضل في خواصه الفيزيائية من المعاملات الاخرى.
- ٢- اظهرت هذه الافلام خواص عالية للتضاد الميكروبي ضد كلا من *Listeria monocytogenes* و *Pseudomonase aeruginosa* و *Fusarium oxysporum*
- ٣- وايضا كان معدل الفقد في الوزن والتغير في رقم الاس الهيدروجيني والعدد الكلي للميكروبات الهوائية والفطريات اقل من المعاملات الأخرى.

\*مدرس الهندسة الزراعية - قسم الهندسة الزراعية - كلية الزراعة - جامعة كفر الشيخ.  
\*\*مدرس تكنولوجيا الاغذية - قسم الصناعات الغذائية - كلية الزراعة - جامعة كفر الشيخ.