



## MANUFACTURE OF A LOCAL MACHINE TO APPLY ORGANIC AND CHEMICAL FERTILIZERS FOR VEGETABLE CULTIVATION IN SANDY SOILS

Mohamed A.A. Salama<sup>1\*</sup>, M.M. Morad<sup>2</sup> and A.S. El-Kot<sup>1</sup>

1. Soil Cons. Dept., Des. Res. Cent., Egypt

2. Agric. Eng. Dept., Fac. Agric., Zagazig Univ., Egypt

### ABSTRACT

A local machine was manufactured to apply compost and chemical fertilizers for vegetable cultivation in sandy soils and evaluate its performance with the traditional method under different operational conditions. The manufactured machine consists mainly of ridger, compost fertilizers applicator, chemical fertilizers applicator and a covering unit. Performance of the manufactured machine was studied as a function of change in machine forward speed, feed shaft rotating speed and furrow depth. The machine performance was evaluated in terms of field capacity, efficiency, uniformity of fertilizers distribution, crop productivity, power and energy requirements. The experimental results revealed that the manufactured machine increased both the uniformity of fertilizer distribution and crop productivity and decreases energy requirements for both organic manure and chemical fertilizers under the conditions of 3.3 km/hr., machine forward speed, 120 rpm feed shaft rotating speed and 20 cm furrow depth.

**Key words:** Manufacture, machine, fertilizers, compost.

### INTRODUCTION

The increase of any crop production in both quantity and quality does not depend only on the improvement of soil and plant conditions, but also largely on using improved methods and technology to fulfill the agricultural processes in correct time, and keep down production cost. General use of fertilizers is essential for producing high yield. Soils of Egypt are known to be poor in available nitrogen specially the sandy soils due to their low content of organic matter. Therefore the application methods of fertilizers for raising the production of most crops should be taken into consideration. On the Egyptian newly reclaimed soils, the organic and chemical fertilizers are often applied and mixed manually in furrows under soil surface during preparing soil to cultivate vegetable crops, causing a great increasing in costs and non-uniform fertilizers distribution which leads to

high variation in crop growth and eventually creates harvesting problems (Metwalli, 2004). The introduction of combined machines performing several technological operations in one run of the unit reduced labor loss from 30 to 50%, fuel consumption from 20 to 30% and increases the yield of farm crops from 10 to 15% compared with single operation machines (Manian *et al.*, 1999). The fertilizer machines are in agricultural of today irreplaceable, because the control of the quantity of the materials mechanically is more accurate, so the uniformity obtained with machine is better than by hand. El-Attar (1995) designed and fabricated a self propeller liquid and organic fertilizer machine for small holding, the primary components of the machine were power tiller (14 hp), one-axial compost spreader, a device mix the compost with soil and injection unit. The results were indicated that the field capacity for broadcasting the compost was 0.18 fad./hr.,

\* Corresponding author: Tel. : +201225019095  
E-mail address: abomomen1975@yahoo.com

at field efficiency 30% and a field capacity for injecting liquid fertilizer was 0.22 fad./hr., at field efficiency 65%. The energy requirements for broadcasting compost were 1.357 and 1.879 kW.hr./fad., and for injection liquid fertilizer were 6.67 and 4.123 kW.hr./fad., through unplowed and plowed surface, respectively. The cost of broadcasting compost through the labors was higher when compared with the machine, the relative increase was 17%. El-Bahrawy (1998) designed and fabricated a prototype of fertilizer application equipment, that can apply the mineral fertilizer in furrow trenches into the citrus orchard soil, also evaluated its performance throughout three depths of 5, 10, and 15 cm and three fertilizer rate of 450, 675 and 900 kg ammonium sulphate/fad., under two different speeds of 1.8 and 2.4 km/hr. He found that the operation speed had not significant effect on all studies parameters, whereas the adjustment of the fertilizer rate was done through the feed opening at the used speed. The effect of the both depths of 10 and 15 cm was nearly similar and greater than the depth of 5 cm under all study parameters at the same fertilizer rate. Wagdy (1999) developed the conventional fertilizers machine from broadcast application to in row application by fixing the spreader spinner inside a collector box and connected the box under the hopper of the machine and fixing the machine on the tool bar with four furrow openers to use the developed machine as a row crop fertilizing machine. Awad (2002) developed the ordinary ridger to be used as a multi-purpose machine for ridging and fertilizing soils during planting cotton crop. The field capacity values were found to be 0.8, 1.15, 1.50 and 1.80 fad./hr., and 0.78, 1.21, 1.40 and 1.67 fad./hr., for the ridgers before and after development at forward speeds of 2, 3, 4 and 5 km/hr., respectively. The maximum cotton yield values of 1.85 and 1.41 Mg/fad., were obtained for ridger after and before development. The maximum values of unit draft were 4.04, 3.37, 4.61 and 4.84 N/cm<sup>2</sup> and 3.43, 3.55, 3.67 and 3.81 N/cm<sup>2</sup> for the ridgers after and before development at the same forward speeds of 2, 3, 4, and 5 km/hr., respectively. Also the values of the unit draft were affected by ridging depth, it were (6.04, 4.37, and 3.60 N/cm<sup>2</sup>) and (4.97, 3.55 and 2.64 N/cm<sup>2</sup>) for the ridgers after and

before development at ridging depths of (10, 15 and 20 cm), respectively. Hassan *et al.* (2005) developed the ordinary manure fertilizing machine to be used as dual purpose equipment for spreading different types of fertilizer either manure or chemical, and estimated the optimum forward speed. The results indicated that using of manure fertilizing machine after development at forward speed of about 4.00 km/hr., gave the lowest value of coefficient of variation (14.90%), the optimum application rate of manure (12.860 Mg/fad.), the highest yield (4.90 Mg/fad.) and the lowest value of operation costs of (14.62 LE/fad.) and (2.97 LE/fad.) for manure and chemical fertilization. Fouda (2007) manufactured multi-purposes machine which, was used as a combined unit for; chemical fertilizer dispenser and a profile maker for covering the fertilizer sets with lightly pressed soil. The fertilizer dispenser is supplied its motion using the land wheels. The profile maker is equipped with two opposite moldboards and leveling roll, which produce smooth furrows and a good seed bed for the vegetable crops. The optimum studied parameter for the combined unit with the moldboard profile maker at the sequence condition, forward speed of 5 km/hr., sitting angle of 20° and operating depth of 10 cm to achieve: The optimum fertilizing depth of 7.5 cm for the vegetable crops. Reducing fuel consumption, energy requirement, pulling force, field capacity and field efficiency as a percentage of about 3.41, 11.97, 25.0, 9.84 and 9.84%, respectively compared with the winged unit. The total operating cost was less by about 41.6% than the traditional method.

Meselhy and Elhagary (2014) developed the traditional ridger to be used as a multi-purpose machine for ridging and planting by adding unit to compact and change the shape of bottom furrow (V-shape, trapezoidal shape and W-shape), also adding a planting unit behind the ridger to save time and effort. The results showed that using the developed ridger with W-shape achieved the best values of soil bulk density, soil penetration resistance and average infiltration rate which ultimately resulting the highest value of Millet yield (40.4 Mg/fad.) and the highest value of water use efficiency (10.3 kg/m<sup>3</sup>).

Manufacture of multi-purposes machine technology for applying organic and chemical fertilizers during preparing soil to plant vegetable crops is a great importance to save time, labor and cost and obtained high uniformity of fertilizers distribution. So the objectives of the present study are to:

- Develop and manufacture of a local multi-purposes machine for ridging and applying organic and chemical fertilizers in furrows.
- Optimize some operating parameters affecting the developed machine performance.

## MATERIALS AND METHODS

The experiments of this study were divided into two main parts. The first part (laboratory experiments) was conducted at Compost El-Bostan Company, Belbies, Sharkia Governorate, Egypt to optimize some operating parameters affecting the application rate and the fertilizers distribution efficiency. While the second part (field experiments) were carried out through two successful agricultural winter seasons of 2011/2012 and 2012/2013 at South of Qantara, Ismaillia Governorate, Egypt, to evaluate and optimize some operating parameters affecting the proposed machine performance during seed bed preparation for planting snap beans (*Phaseolus vulgaris* L.) under sandy soil and drip irrigation conditions. The mechanical analyses of the experimental soil are shown in Table 1.

### Materials

#### The Cultivated Crop

Snap beans (Ogzira) planted on 10<sup>th</sup> of Oct. 2011 and 8<sup>th</sup> Oct. 2012 at seed rate of 30 kg/fad., on an area of about 1 fad., under drip irrigation system. It was picked manually five times as fresh green pods. The agricultural practices of all the experimental treatments were done as usual in the area.

#### The organic and chemical fertilizers

Compost applied at the rate of 20 m<sup>3</sup>/fad., while chemical fertilizers were mixed and applied at application rate of 400 kg/fad. The mixture was consisted of 200 kg super phosphate calcium/fad., + 100 kg ammonium

sulphate/fad., + 100 kg sulfur/fad., during bed preparation, some physical properties of compost and chemical fertilizers were determined as shown in Table 2.

### Tractor

Tractor Belaruss MTZ-80, 4-strokes, Diesel engine, 66.2 kW (90 hp) was used a power source for operating the manufactured machine.

### The Manufactured Machine

Multi-purposes machine, which was used as a combined unit was manufactured in a local engineering workshop to consist the following main parts:

#### Frame and wheel

The frame of proposed machine was used for fixing all components. It consists of steel beam with (U) cross section of 60 × 120 and thickens of 5 mm. The frame width was 1500 mm and 2000 mm length mounted on two rubber tires with size of 16-5/25.

#### Ridging unit

Riding unit consists of two shanks fixed in frame bar, operating width and height can be adjusted. The width was from 600 to 1200 mm and the height was from 40 to 700 mm. The dimensions of each shank was 800 mm length and cross section area of 40 x 80 mm connected with a chisel blade and two wings. Each wing has a curved shape with dimensions of 175 × 200 mm welded on the end edge of shank.

#### Organic fertilizers application unit

Organic fertilizers application unit consists of the following parts:

#### Organic fertilizers box

Organic fertilizers box was mounted on the front of the frame, it was made from galvanized steel of 2 mm thickness. The box has a rectangular shape at the top 1500 × 1800 × 600 mm while the bottom has a trapezoid shape. The full capacity of the box is 2000 liters. Two outlet orifices were provided at the bottom of the box with a rectangular shape of 300 × 400 mm to deliver fertilizers into feeding device.

**Table 1. Mechanical analysis of the experimental soil**

Soil depth, cm	Sand (%)		Silt (%)	Clay (%)	Soil texture	CaCO <sub>3</sub> (%)
	Coarse	Fine				
0-10	78.76	14.66	2.54	4.04	sand	2.61
10-20	76.94	15.42	3.26	4.38	sand	2.34
20-30	76.16	15.95	3.57	4.32	sand	2.94

**Table 2. Some physical properties of compost and chemical fertilizers**

Type of fertilizer	Grade	Bulk density, g/cm <sup>3</sup>	Repose angle	Friction angle	Friction coefficient against steel	Form of fertilizer
Compost	32% O.M	0.65	43.6	33.8	0.67	-
Super phosphate	15.5% P <sub>2</sub> O <sub>5</sub>	0.91	36.4	28.2	0.53	Granular
Ammonium sulphate	33.5% N	0.98	31.5	24.1	0.45	Crystalline salt
Sulfur	98%	0.96	37.1	29.3	0.56	Granular

### The agitator

An agitator made of steel shaft 25 mm diameter. It was fixed inside the box to keep fertilizer moving and grind compost blocks in the box.

### The organic fertilizer feeding device

Two augers were fixed on the frame for controlling fertilizer movement from feed orifice to fertilizer tube. The dimensions of each auger was 1080 mm length, 149 mm screw flight diameter, 36 mm screw shaft diameter, 180 mm pitch length. The volumetric capacity of each auger was 2980 cm<sup>3</sup>.

### Fertilizer tubes

Two rubber tubes of 160 mm diameter and 400 mm length are connected to the outlet of each auger to deliver fertilizers inside the furrow.

### Chemical fertilizers application unit

Chemical fertilizers application unit consists of the following parts:

### Chemical fertilizer box

Chemical fertilizer box was mounted on frame rear, it was made from galvanized steel 2 mm thickness. The box has a rectangular shape at the top 1500 × 200 × 600 mm, while at the bottom, it has a trapezoid shape. The full capacity of the box is 220 liters. Two outlet orifices were provided at the bottom of the box with a rectangular shape of 100 × 80 mm to deliver fertilizers into feeding device.

### The agitator

An agitator made of steel shaft 25 mm diameter, was fixed inside the box to keep fertilizer moving and grind fertilizer blocks in the box.

### The fertilizer feeding device

Two feed discs in casing were made of steel, each disc was fixed on the end of auger shaft. The dimensions of each disc were 200 mm out diameter, 50 mm thickness. The disc consists of 10 cells, the dimensions of each cell were 12.5 × 10 × 50 mm, the volume of each cell was 6.25 cm<sup>3</sup>. The volumetric capacity of each disc was 62.5 cm<sup>3</sup>.

### Fertilizer tubes

Two rubber tubes of 50 mm diameter and 400 mm length are connected to the outlet of casing to deliver fertilizers inside the furrow.

### Transmission system

The source of power from tractor P.T.O. shaft by universal joint to gearbox which has three reduction ratio of rotating speed (1:1, 1:1.5 and 1:2). The gearbox transmits the motion from P.T.O. to the agitators and feed shafts

### Covering unit

The covering device designed to cover the furrow after putting organic and chemical fertilizers. There were two device mounted behind the chemical fertilizer box on the rear of the frame. The covering unit was having movement up and down through out three arms as shown in Fig. 1.

## Methods

### Experimental Conditions

#### Laboratory experiments

Laboratory experiments were conducted to estimate the optimum rotating speed of feed shaft and machine forward speed as follows:

- Six feed shaft rotating speeds (60, 80, 100, 120, 140 and 160 rpm).
- Five machine forward speeds (1.7 , 2.5 , 3.4 , 4.2 and 5.1 km/hr.).

### Measurements of laboratory experiments

Evaluation of the manufactured machine in the laboratory was based on the following indicators:

#### Fertilizers discharge rate

Fertilizers discharge rate (R, kg/min) was calculated by using the following equation:

$$R = \frac{m}{t}$$

Where:

m: The amount of collected fertilizers, kg

t: The recorded time, min

#### Volumetric efficiency

Volumetric efficiency ( $\eta_v$ , %) was calculated by using the following equation:

$$\eta_v = \frac{V_{act}}{V_{th}} \times 100$$



Fig. 1. A photograph of the manufactured machine

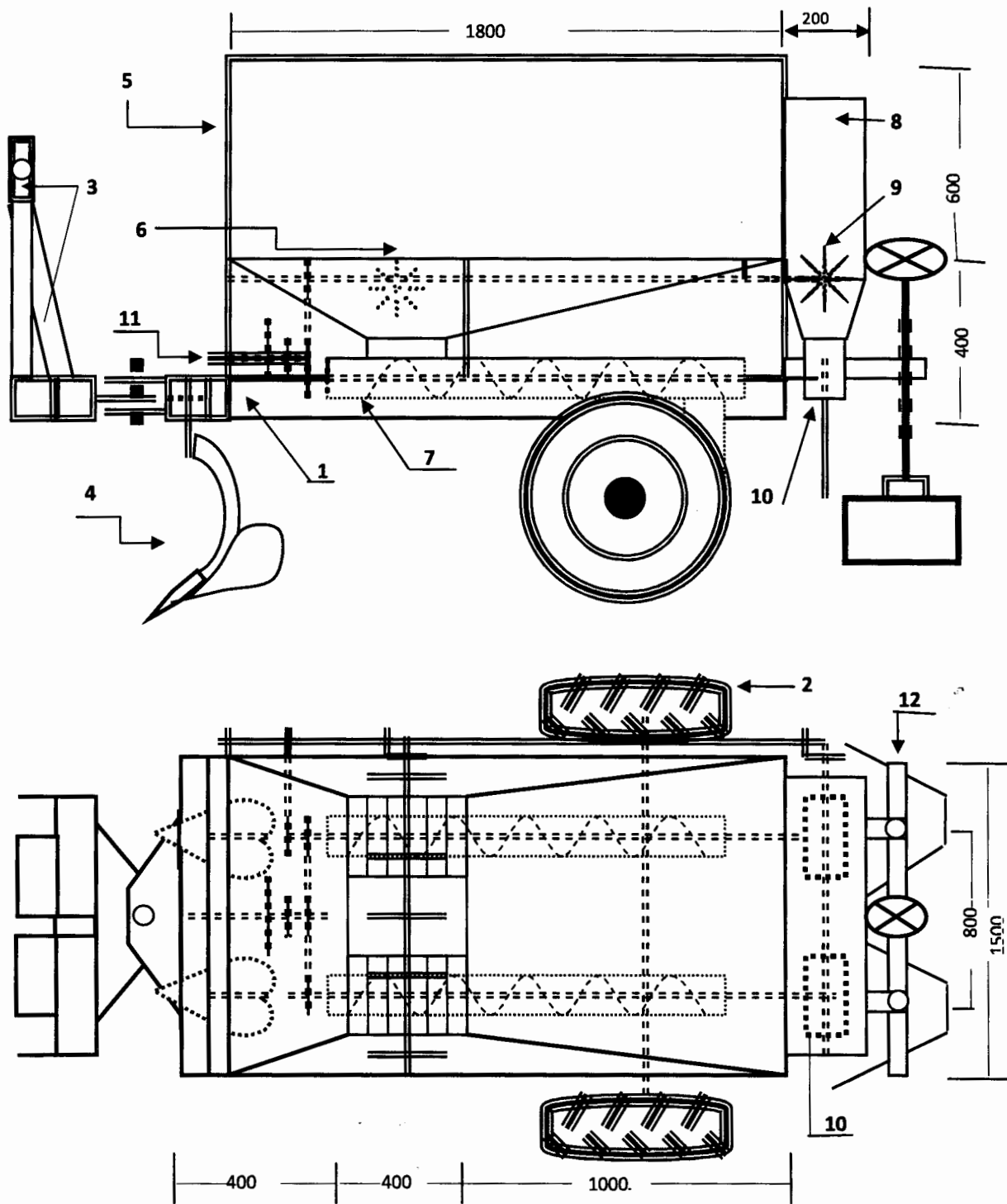

No.	Part name	No.	Part name
1	Frame	7	Auger
2	wheel	8	Chemical Fertilizer box
3	Attachment points	9	Chemical agitator
4	Ridger	10	Chemical feed disc
5	Manure box	11	Transmission system
6	Manure agitator	12	Covering unit

Fig. 2. A sketch of the manufactured machine

Where:

Vact: Actual volume capacity, cm<sup>3</sup>/min

Vth: theoretical volume capacity, cm<sup>3</sup>/min

The theoretical volumetric capacity of the auger was defined by (Ismail *et al.*, 2011) as:

$$V_{aug} = \frac{\pi}{4} [(d_{sf})^2 - (d_{ss})^2] I_p \cdot N$$

Where:

V<sub>aug</sub> : The volume of auger unit, cm<sup>3</sup>

d<sub>sf</sub> : Screw flight diameter, cm

d<sub>ss</sub> : Screw shaft diameter, cm

I<sub>p</sub> : Pitch length, cm

N: Rotating speed of auger

Theoretical volume of auger was 2980 cm<sup>3</sup> while Theoretical volume of feed disc was 62.5 cm<sup>3</sup>.

### The application rate

The application rate of compost during seed bed preparation for planting Snap bean under sandy soil conditions is 20 m<sup>3</sup>/fad. So the compost bulk density was determined and the application rate of compost was determined as follow:

$$R_{th} = D \times \rho$$

Where:

R<sub>th</sub>: The theoretical application rate, kg/fad.

D: the application rate, m<sup>3</sup>/fad. (20 m<sup>3</sup>/fad.)

ρ : Bulk density, g/cm<sup>3</sup> (0.65 g/cm<sup>3</sup> for compost)

R<sub>th</sub> = (20 x 1000)0.65 R<sub>th</sub>=13000 kg/fad.

When distance between the furrows is 1 m, the theoretical application rate for one meter is determined as flow:

$$R_{th} = \frac{13000}{4200} = 3.1 \text{ kg/m}$$

This means that compost should be applied at 3.1 kg for every one meter of furrow. The same theoretical consideration was determined for the application rate of chemical fertilizers as follow:

$$R_{th} = D \times 1000/4200 \text{ g/m}$$

Where:

R<sub>th</sub>: The theoretical applied rate, g/m

D: the amount of chemical fertilizers (400 kg/fad.)

When distance between the furrows is 1 m, the theoretical application rate is determined as follow:

$$R_{th} = \frac{400 \times 1000}{4200} = 95.2 \text{ g/m}$$

This means that chemical fertilizer should be applied at 95.2 g for every one meter of furrow

The actual application rate was calculated by using the following equation:

$$R_{act} = \frac{m}{L} \text{ kg/m}$$

Where:

R<sub>act</sub>: The actual application rate, kg/m

m: The amount of collected fertilizers, kg

L: The recorded distance, m

### The uniformity of fertilizers distribution

Standard deviation, coefficient of variation and coefficient of uniformity were run for each test and calculated as the following:

Coefficient of variation (C.V) was calculated as the following:

$$X_a = \frac{\sum x_i}{n} \quad \delta = \sqrt{\frac{\sum (x_i - x_a)^2}{n-1}}$$

$$C.V = \frac{\delta}{X_a} \times 100$$

Where:

X<sub>i</sub>: The individual collection points

X<sub>a</sub>: The arithmetic mean

n: Total number of collection point

δ : Standard deviation

C.V: Coefficient of variation (%),

Coefficient of uniformity (C.U %) was calculated as the following formula (Dragos, 1975);

$$C.U = \left[ 1 - \frac{\sqrt{\frac{\sum (x_i - x_a)^2}{n-1}}}{X_a} \right] \times 100$$



### The field experiments

Field experiments were carried out under the following conditions:

- Three machine forward speeds at three feed shaft rotating speeds as follows.
  - 2.3 km/hr., at 80 rpm
  - 3.3 km/hr., at 120 rpm
  - 4 km/hr., at 160 rpm
- Three furrow depths (15, 20 and 25 cm).

### Measurements of field experiments

Evaluation of the manufactured machine performance in the field was based on the following indicators:

#### Machine field capacity

The theoretical field capacity was determined by the following formula (Hanna *et al.*, 1985):

$$P_{th} = \frac{S \times W}{4200}$$

Where;

$P_{th}$ : The theoretical capacity of machine, fad./hr.

S: Travel speed, m/hr.

W: Operating wide, m

#### Field efficiency

The field efficiency was determined by the following formula

$$E_f = \frac{P_{act}}{P_{th}} \times 100$$

Where:

$E_f$ : The field efficiency (%)

$P_{act}$ : The actual capacity of the machine, fad./hr.

$P_{th}$ : The theoretical capacity of machine, fad./hr.

#### Slip percentage

The slip (S, %) was determined by the following formula:

$$S = \frac{L_{th} - L_{act}}{L_{th}} \times 100\%$$

Where:

$L_{th}$ : the calculated advance per 10 wheel revolutions without load, m

$L_{act}$ : the calculated advance per 10 wheel revolutions under load, m

### Crop productivity

Snap beans was picked manually five times as fresh green pods and the total crop productivity was determined for each treatment.

### Fuel consumption

Fuel consumption rate ( $F_c$ , L/hr.) was determined by the following equation:

$$F_c = \frac{V_f}{T} \times 3.6$$

Where :

$V_f$ : Volume of fuel consumed,  $cm^3$

T: Time of operation, sec

### The required power

The required power was estimated by using the following formula (Barger *et al.*, 1963)

$$PR = F_c \frac{1}{3600} \times \rho \times LCV \times 427 \times \eta_{th} \times \eta_m \times \frac{1}{1.36} \times \frac{1}{75}$$

Where:

PR: The required power, kW

$F_c$ : Fuel consumption rate, L/hr

$\rho$ : Fuel density,  $g/cm^3$  (0.85 for solar)

LCV: Lower calorific value of fuel (for solar = 10000 k cal/kg)

427: Thermal-mechanical equivalent, kg.m/k cal

$\eta_{th}$ : Thermal efficiency (40% for diesel engine)

$\eta_m$ : Mechanical efficiency (80% for diesel engine)

### Energy requirements

The energy requirements was calculated as follow:

$$ER = \frac{PR}{EFC}$$

ER: The energy requirements, kW.hr./fad.

PR: The required power, kW.

EFC: Effective field capacity, fad./hr.



## RESULTS AND DISCUSSION

Data obtained from the laboratory and field experiments to evaluate the performance of the manufactured machine were discussed under the following items.

### Results of the Laboratory Experiments

#### Effect of Feed Shaft Rotating Speed on Fertilizers Discharge Rate and Volumetric Efficiency

##### Discharge rate

The effect of feed shaft rotating speed on fertilizers discharge rate was illustrated in Fig. 3. In general, a linear relationship between the discharge rate (kg/min) and feed shaft rotating speed (rpm) up to 120 rpm. Beyond this value, there was irregular relationship. This trend may be attributed to that by increasing the rotating speed of feed shaft, the centrifugal force decreases the fertilizers flow.

The increasing percentage of compost discharge rate by increasing rotating speed from 60 to 100 rpm was 69% while, by increasing rotating speed from 120 to 160 rpm the increasing percentage of compost discharge rate was 16%. The same trend was detected for the feed disc, the increasing percentage of chemical fertilizers discharge rate by increasing rotating speed from 60 to 100 rpm was 70%, while by increasing rotating speed from 120 to 160 rpm the increasing percentage of chemical fertilizers discharge rate was 16.5%.

##### Volumetric efficiency

The effects of the feed shaft rotating speed on the volumetric efficiency were illustrated in Fig. 4. The general trend of this relationship is that the volumetric efficiency increases with increasing the rotating speed up to 120 rpm for both compost and chemical fertilizers. Beyond this value, the volumetric efficiency decreased by increasing the rotating speed. This trend may be attributed to that after 120 rpm; the centrifugal force restricts the flow of fertilizers.

The results indicated that the highest value of the auger volumetric efficiency was 78.71% at feed shaft rotating speed of 120 rpm while, the lowest value was 68.35% at feed shaft rotating

speed of 160 rpm. The same trend was recorded for the feed disc, whereas the highest value of the disc volumetric efficiency was 80.63% at feed shaft rotating speed of 120 rpm while, the lowest value was 70.46% at feed shaft rotating speed of 160 rpm.

The same results indicated that the volumetric efficiency of feed disc recorded higher values than the volumetric efficiency of auger under the same conditions. This trend may be attributed to that the volumetric efficiency was affected by the density of fertilizers and the shape of fertilizer particles.

#### Effect of Feed Shaft Rotating Speed and Forward Speed on the Application Rate and the Uniformity of Fertilizers Distribution

##### The application rate

The actual application rate was determined and the results were illustrated in Fig. 5. The results indicated that the highest value of compost application rate was 7.22 kg/m, which was obtained at auger rotating speed of 160 rpm and 1.7 km/hr., forward speed. Meanwhile the lowest value was 1.01 kg/m, at auger rotating speed of 60 rpm and 5.1 km/hr., forward speed. The same trend was observed for the feed disc, where the highest value of application rate was 220 g/m, which was obtained at disc rotating speed of 160 rpm and 1.7 km/hr., forward speed. Meanwhile the lowest value was 37 g/m, at disc rotating speed of 60 rpm and 5.1 km/hr., forward speed.

From Fig. 5 the results indicated that, generally by increasing forward speed, the application rate was decreased. So by increasing forward speed from 1.7 to 2.5 km/hr., the application rates of compost were decreased from 3.13 to 2.12, from 4.20 to 2.85, from 5.21 to 3.54, from 6.09 to 4.14, from 6.8 to 4.64 and from 7.22 to 4.89 kg/m at auger rotating speeds of 60, 80, 100, 120, 140 and 160 rpm, respectively. However, by increasing forward speed from 4.2 to 5.1 km/hr., the application rates of compost were decreased from 1.25 to 1.01, from 1.68 to 1.37, from 2.09 to 1.71, from 2.44 to 2, from 2.72 to 2.22 and from 2.88 to 2.36 kg/m at auger rotating speed of 60, 80, 100, 120, 140 and 160

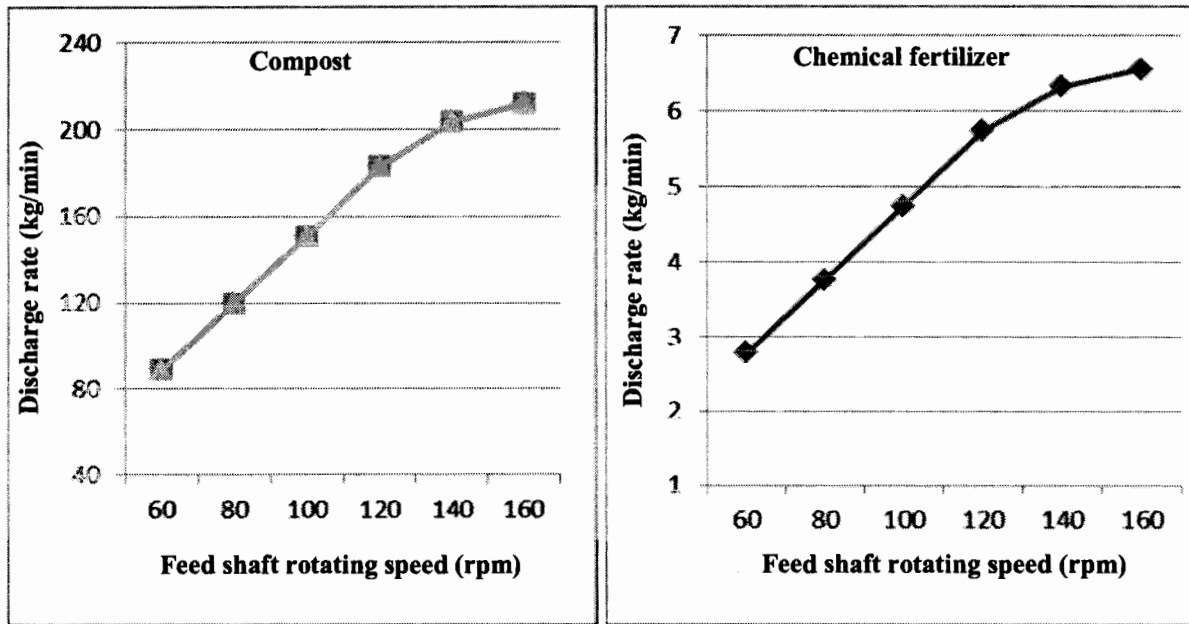

Fig. 3. Effect of feed shaft rotating speed on fertilizer discharge rate

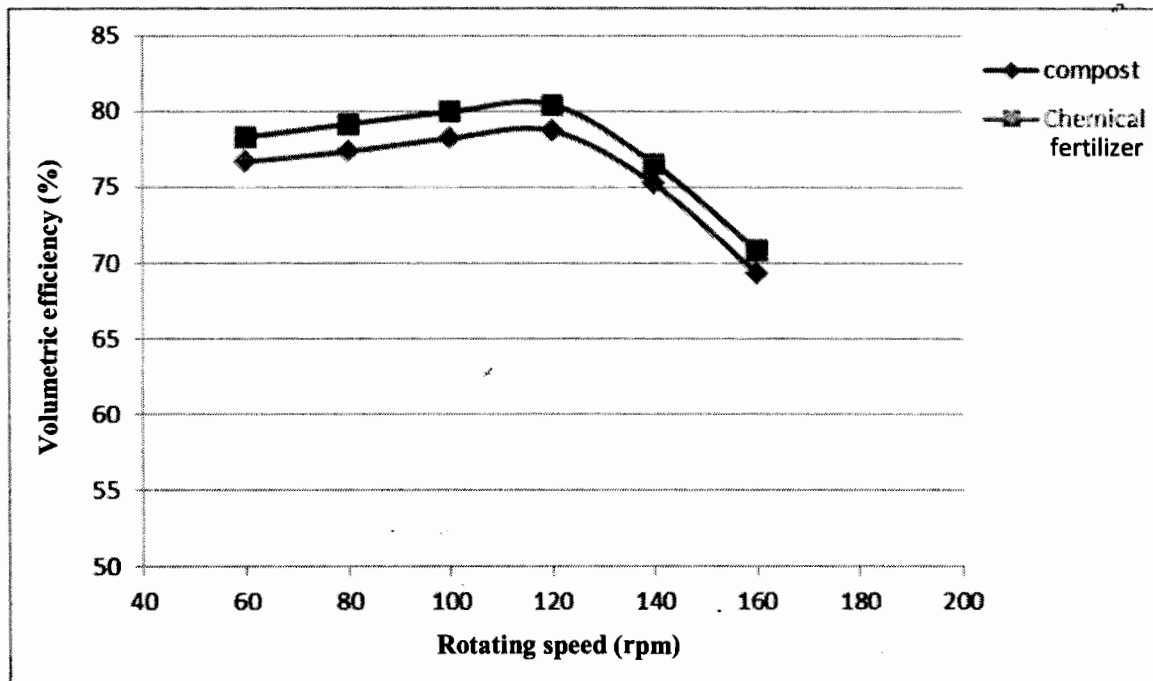

Fig. 4. Effect of feed shaft rotating speed on volumetric efficiency

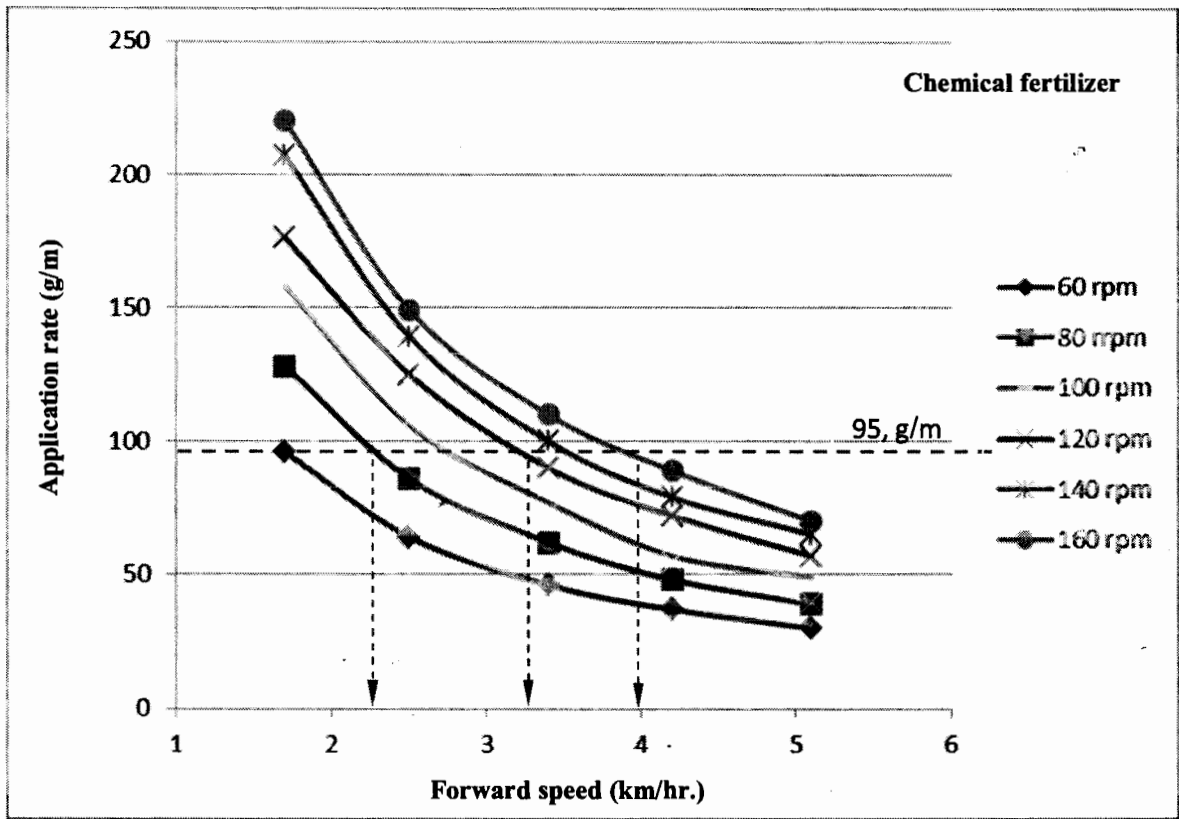
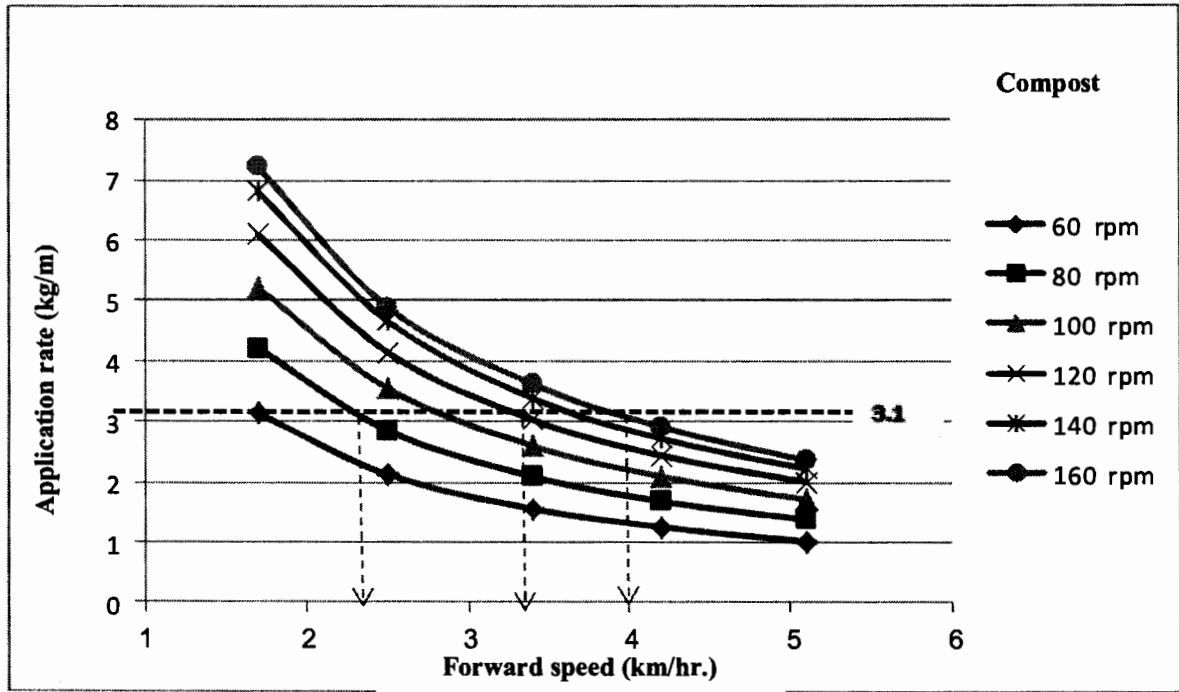

Fig. 5. Effect of feed shaft rotating speed and forward speed on chemical fertilizers application rate

rpm, respectively. The same trend was achieved for the chemical fertilizers, where by increasing forward speed from 1.7 to 2.5 km/hr., the application rates were decreased from 96 to 64, from 128 to 86, from 158 to 107, from 176 to 118, from 207 to 140 and from 220 to 148 g/m at disc rotating speeds of 60, 80, 100, 120, 140 and 160 rpm, respectively. However, by increasing forward speed from 4.2 to 5.1 km/hr., the application rates of chemical fertilizers were decreased from 37 to 30, from 48 to 39, from 57 to 46, from 70 to 57, from 79 to 64 and from 86 to 68 g/m at auger rotating speeds of 60, 80, 100, 120, 140 and 160 rpm, respectively. This trend may be attributed to the volumetric capacity was affected by increasing the rotating speed.

The same results indicated that, generally by increasing rotating speed, the application increased. So by increasing auger rotating speed from 60 to 80 rpm, the application rates of compost were increased from 3.31 to 4.2, from 2.12 to 2.85, from 1.55 to 2.09, from 1.25 to 1.64 and from 1.01 to 1.37 kg/m at forward speed of 1.7, 2.5, 3.4, 4.2 and 5.1 km/hr., respectively. However, by increasing auger rotating speed from 140 to 160 rpm, the application rates were increased from 6.8 to 7.22, from 4.64 to 4.89, from 3.38 to 3.58, from 2.72 to 2.88 and from 2.22 to 2.36 kg/m at forward speed of 1.7, 2.5, 3.4, 4.2 and 5.1 km/hr., respectively.

The same trend was found for the chemical fertilizers, where by increasing disc rotating speed from 60 to 80 rpm, the application rates were increased from 96 to 128, from 64 to 86, from 46 to 62, from 37 to 48 and from 30 to 39 g/m at forward speed of 1.7, 2.5, 3.4, 4.2 and 5.1 km/hr., respectively. However, by increasing disc rotating speed from 140 to 160 rpm, the application rates were increased from 207 to 220, from 140 to 148, from 100 to 108, from 79 to 86 and from 64 to 68 kg/m at forward speed of 1.7, 2.5, 3.4, 4.2 and 5.1 km/hr., respectively.

Referring to Fig. 5, it was found that the optimum forward speeds of the manufactured machine, which achieved the optimum application rate (3.1 kg/m for compost and 95.2 g/m for chemical fertilizers) are 2.3, 3.3 and 4 km/hr., at using rotating speeds of 80, 120, 160

rpm, respectively. Therefore field experiments were carried out under the previous recommended parameters during seed bed preparation for planting snap beans.

#### Uniformity of fertilizers distribution

The effects of the feed shaft rotating speed on uniformity of fertilizers distribution at different forward speeds were illustrated in Fig. 6. The general trend is that the uniformity of fertilizers distribution increases with increasing the rotating speed up to 120 rpm for the auger and feed disc at different forward speeds. Beyond this value, the uniformity of fertilizers distribution decreased by increasing the rotating speed at different forward speeds. This trend may be attributed to the volumetric efficiency which was increased by increasing rotating speed up to 120 while it decreased beyond this value.

The results indicated that the highest values of the uniformity of fertilizers distribution were 98.02 and 97.74% for chemical fertilizers and compost, respectively at feed shaft rotating speed of 120 rpm and 1.7 km/hr., forward speed, while the lowest values were 88.13 and 88.82% for chemical fertilizers and compost, respectively at feed shaft rotating speed of 160 rpm and 5.1 km/hr., forward speed.

The general trend is that the uniformity of fertilizers distribution decreases with increasing forward speed at different rotating speeds. When forward speed increased from 1.7 to 3.4 km/hr., the uniformity of fertilizers distribution decreased from 97.74 to 96.83% and from 98.02 to 96.89% for the compost and chemical fertilizers, respectively at 120 rpm rotating speed. While, by increasing forward speed from 3.4 to 5.1 km/hr., the uniformity of fertilizers distribution decreased from 96.83 to 95.28% and from 96.89 to 95.47% under the same mentioned conditions.

The results indicated that uniformity of distribution of feed disc recorded higher values than the uniformity of distribution of auger at the same conditions. This trend may be attributed to the volumetric efficiency was affected by the density of fertilizer and the shape of fertilizer particles.

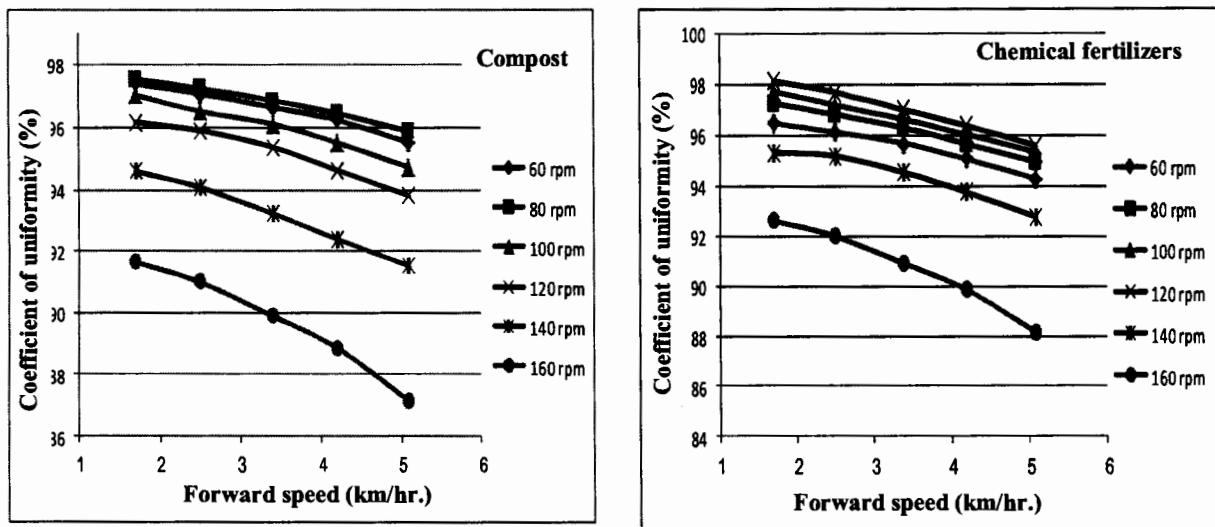

Fig. 6. Effect of the forward speed on coefficient of uniformity of fertilizers distribution at different rotating speed

### Results of Field Experiments

Depending on the obtained data from laboratory results, field experiments were conducted under the recommended forward speeds of 2.3, 3.3 and 4 km/hr., corresponding to feed shaft rotating speeds of 80, 120 and 160 rpm at furrow depths of 15, 20 and 25 cm.

### Effect of Forward Speed and Furrow Depth on Field Capacity, Field Efficiency and Slip Percentage

#### Field capacity

The results indicated that, generally by increasing the forward speed the field capacity was increased, while by increasing the furrow depth the field capacity was decreased. By referring to Fig. 7, it was noticed that increasing forward speed from 2.3 to 4 km/hr., the field capacity increases from 0.77 to 1.26, from 0.69 to 1.12 and from 0.65 to 1.08 fad./hr., at operating depths of 15, 20 and 25 cm, respectively. While, by increasing furrow depth from 15 to 25 cm, the field capacity decreases from 0.77 to 0.65, from 1.08 to 0.90 and from 1.26 to 1.08 fad./hr., at forward speeds of 2.3, 3.3, 4 km/hr., respectively.

Also, the results indicated that, the maximum value of field capacity was 1.26 fad./hr., which obtained at furrow depth of 15 cm and forward speed of 4 km/hr. While the minimum value was

0.65 fad./hr., at furrow depth of 25 cm and forward speed of 2.3 km/hr. This trend may be attributed to that the increasing in operating depth caused an increase in the resistance of soil layer and more time consumed.

#### The field efficiency

As shown in Fig. 8, it was obvious that by increasing the forward speed from 2.3 to 4 km/hr., the field efficiency was decreased from 70.64 to 66.31, from 63.30 to 58.95 and from 59.63 to 56.84% at furrow depths of 15, 20, 25 cm, respectively. The same trend was shown for the furrow depth, where by increasing furrow depth from 15 to 25 cm, the field efficiency decreases from 70.64 to 59.63, from 68.79 to 57.32 and from 66.31 to 56.84% at forward speeds of 2.3, 3.3 and 4 km/hr., respectively.

The maximum value of field efficiency was 70.64%, at furrow depth of 15 cm and forward speed of 2.3 km/hr. While the minimum value was 56.84%, at furrow depth of 25 cm and forward speed of 4 km/hr.

#### Slip percentage

Slip percentage was determined and the results were illustrated in Fig. 9. Generally by increasing the forward speed the Slip was increased, while by increasing the furrow depth the field capacity was decreased. The same trend

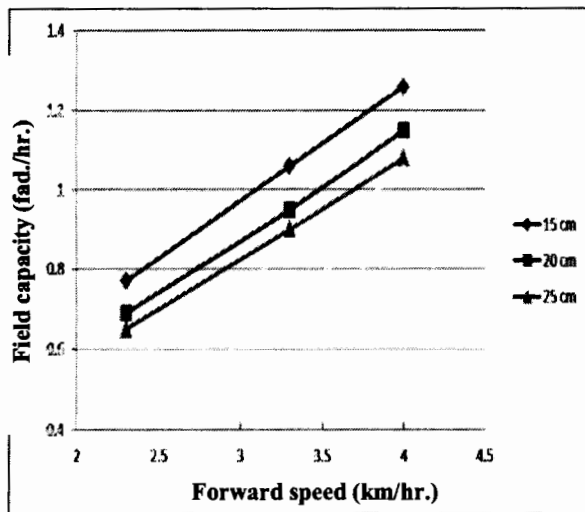

Fig. 7. Effect of forward speed and furrow depth on the machine field capacity

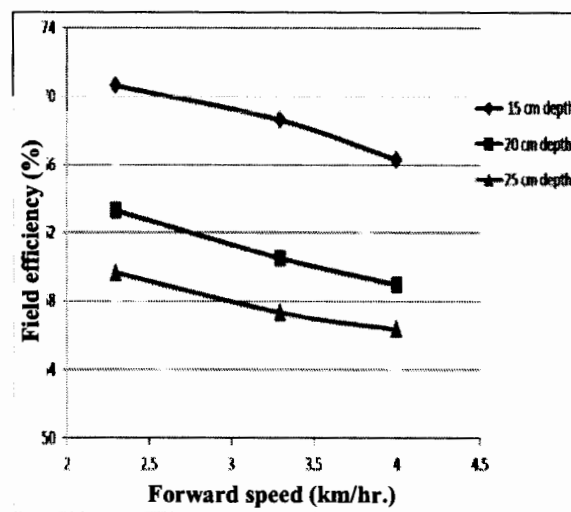

Fig. 8. Effect of forward speed and furrow depth on the field efficiency

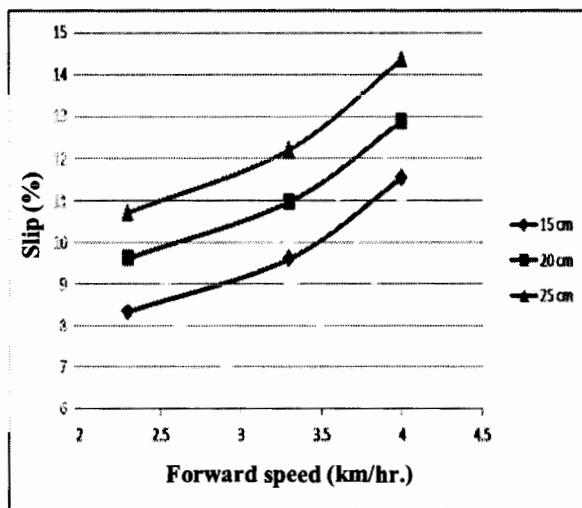

Fig. 9: Effect of forward speed, and furrow depth on the slip percentage

was recorded for the furrow depth, by increasing furrow depth, where the slip was increased. The maximum value of slip was 14.36%, at furrow depth of 25 cm and forward speed of 4 km/hr. While the minimum value was 8.34%, at furrow depth of 15 cm and forward speed of 2.3 km/hr.

As shown in Fig. 9, it was obvious that by increasing the forward speed from 2.3 to 4 km/hr., the slip was increased from 8.34 to 11.54, from 9.63 to 12.88 and from 10.71 to 14.36% at furrow depths of 15, 20, 25 cm, respectively. The same trend was detected for the furrow depth, where by increasing furrow depth from 15 to 25 cm, the

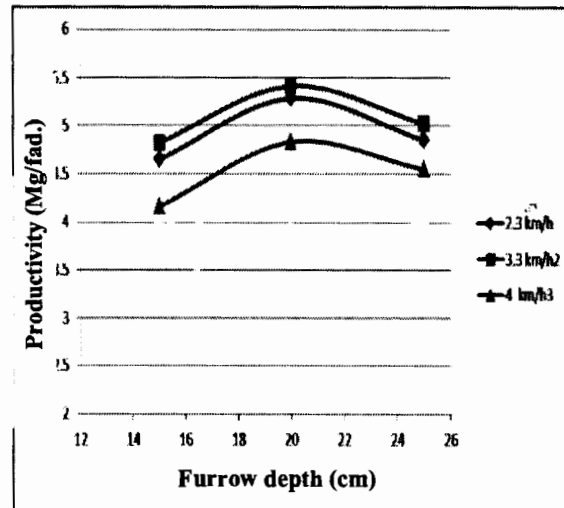

Fig. 10. Effect of furrow depth on crop productivity at different forward speed

slip increases from 8.34 to 10.71, from 9.61 to 12.21 and from 11.54 to 14.36% at forward speeds of 2.3, 3.3 and 4 km/hr., respectively.

#### Effect of using the manufactured machine on crop productivity

Snape beans was picked as fresh green pods manually and the total crop productivity was determined as shown in Fig. 10. From the obtained data it can be noticed that, using the manufactured machine at forward speed of 3.3 km/hr., rotating speed of 120 rpm and furrow depth of 20 cm gave the best result (5.44 Mg/fad.) compared with other treatments.

From the previous data, it was noticed that, by increasing the furrow depth from 15 cm to 25 cm, the crop productivity was increased from 4.65 to 4.85, from 4.82 to 5.02 and from 4.16 to 4.55 Mg/fad., at forward speeds of 2.3, 3.3 and 4 km/hr., respectively. By increasing the forward speed from 2.3 to 4 km/hr., the total crop productivity was decreased from 4.65 to 4.16, from 5.28 to 4.83 and from 4.85 to 4.55 Mg/fad., at furrow depths of 15, 20, 25 cm, respectively.

The increasing percentage in crop productivity was 36.2% when using the manufactured machine at the optimum operating parameters (forward speed of 3.3 km/hr., rotating speed of 120 rpm and furrow depth of 20 cm).

### **Effect of Forward Speed and Furrow Depth on Fuel Consumption, Power Requirement and Energy Requirements**

#### **Fuel consumption**

The fuel consumption was recorded by l/hr., at different treatments, the data were illustrated in Fig. 11. The results indicated that the highest value of fuel consumption was 17.89 l/hr., which obtained at furrow depth of 25 cm and forward speed of 4 km/hr. While the lowest value was 11.02 l/hr., at furrow depth of 15 cm and forward speed of 2.3 km/hr.

Generally by increasing the forward speed and furrow depth the fuel consumption was increased. By increasing the forward speed from 2.3 to 4 km/hr., the fuel consumption was increased from 11.02 to 15.53, from 12.11 to 16.15 and from 12.17 to 17.89 l/hr., at furrow depths of 15, 20, 25 cm, respectively. While by increasing the furrow depth from 15 cm to 25 cm the fuel consumption was increased from 11.02 to 12.32, from 12.71 to 14.41 and from 15.53 to 17.89 l/hr., at forward speeds of 2.3, 3.3 and 4 km/hr., respectively.

#### **Required power**

Required power was determined from fuel consumption and the results were illustrated in Fig. 12. Generally by increasing the forward speed, the required power was increased. The same trend was noted for the furrow depth, whereas by increasing furrow depth, the required power was increased. The maximum value of

required power was 56.53 kW at furrow depth of 25 cm and forward speed of 4 km/hr. While the minimum value was 34.82 kW at furrow depth of 15 cm and forward speed of 2.3 km/hr.

As shown in Fig. 12, it was obvious that by increasing the forward speed from 2.3 to 4 km/hr., the required power was increased from 34.82 to 49.07, from 38.27 to 51.03 and from 40.16 to 56.53 kW at furrow depths of 15, 20, 25 cm, respectively. The same trend was found for the furrow depth, where by increasing furrow depth from 15 to 25 cm, the required power increases from 34.82 to 40.16, from 38.93 to 45.52 and from 49.07 to 56.53 kW at forward speeds of 2.3, 3.3 and 4 km/hr., respectively.

#### **Energy requirements**

Generally by increasing the furrow depth the energy requirements was increased. By increasing the furrow depth from 15 cm to 25 cm, the energy requirements was increased from 45.22 to 61.78, from 36.04 to 50.58 and from 38.94 to 52.34 kW.hr./fad., at forward speeds of 2.3, 3.3 and 4 km/hr., respectively. While by increasing the forward speed from 2.3 to 3.3 km/hr., the energy requirements was decreased at different furrow depths, but increasing the forward speed more than 3.3 km/hr., led to increase the energy requirements at different furrow depths. This increase may be due to the high consumption of fuel rate when used forward speed up to 3.3 km/hr.

As shown in Fig. 13, it was obvious that the highest value of energy requirements was 61.78 kW.hr./fad., which obtained at furrow depth of 25 cm and forward speed of 2.3 km/hr. While the lowest value was 36.06 kW.hr./fad., at furrow depth of 15 cm and forward speed of 3.3 km/hr.

#### **Conclusion**

The experimental results revealed that the manufactured machine increased both uniformity of fertilizer distribution and crop productivity and decreases energy requirements for both compost and chemical fertilizers under the following conditions:

Machine forward speed of 3.3 km/hr., feed shaft rotating speed of 120 rpm and furrow depth of 20 cm.



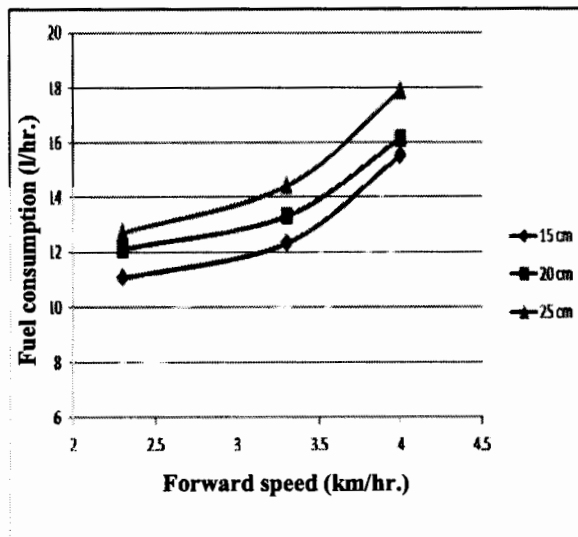

Fig. 11. Effect of forward speed and furrow depth on fuel consumption

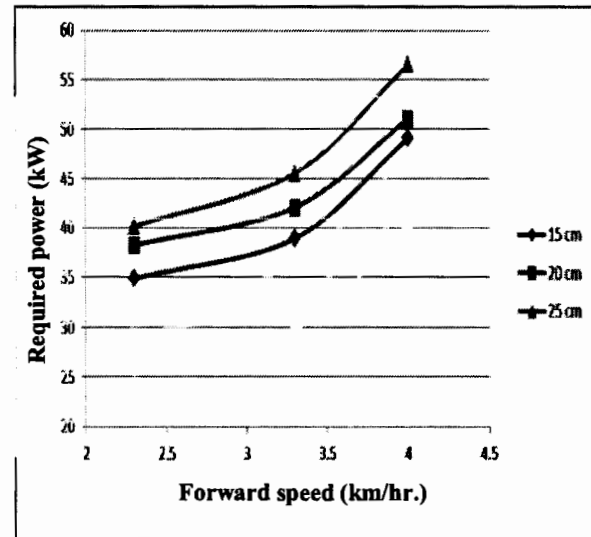

Fig. 12. Effect of forward speed, and furrow depth on the required power

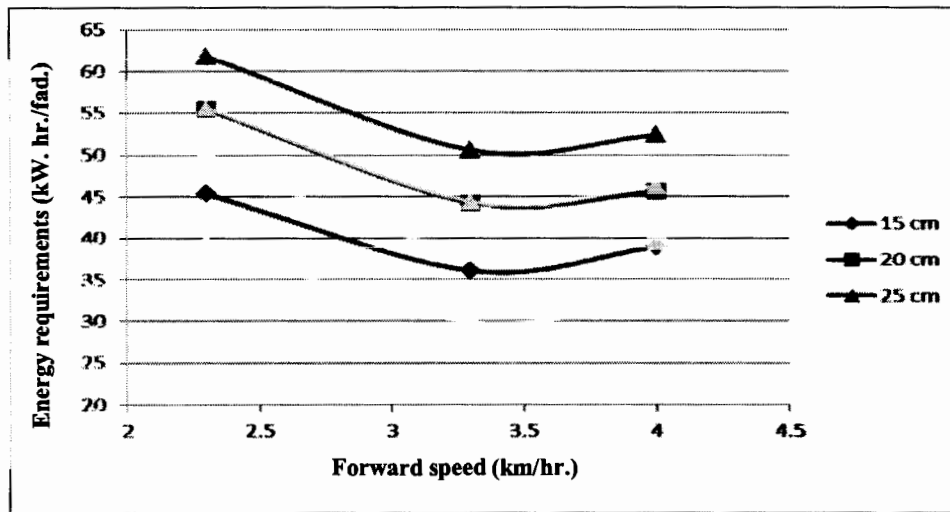

Fig. 13. Effect of forward speed and furrow depth on Energy requirements

## REFERENCE

- Awad, M.C.A. (2002). Development of multi-purposes machine for ridging and fertilizing soils under Egyptian conditions. Ph.D. Thesis, Zagazig Univ., Egypt.
- Barger, E.L., J.B. Ljedahl, W.M. Carleton and E.G. Mekibben (1963). Tractor and Their Power Units. 2<sup>nd</sup> Ed., John Wiley Sons. Inc., New York. USA.
- Dragos, T. (1975). Farm Machinery and Equipment. Hand book. Ministry of Education. Poucharest, Romania, 272.
- El-Attar, M.A. (1995). Performance of self propeller liquid and organic fertilizers machine for small holding. Ph.D. Thesis, Ain-Shams Univ., Egypt.
- El-Bahrawy (1998). A prototype of fertilizing equipment used in citrus orchards. Ph.D. Thesis, Zagazig Univ., Egypt.

- Fouda, O.S. (2007). A combined unit to prepared the bed of some vegetable crops. Ph.D. Thesis, Fac. Agric., Mansoura Univ., Egypt
- Hanna, G.B., A.E. Suliman, S.M. Younis and A.Z. Taif (1985). Evaluation of different mechanical methods of cotton stalks removal. *Misr J. Agric. Eng.*, 9 (1): 3-25.
- Hassan, M.A., M.M. Morad and M. Tawfik (2005). Development of manure fertilizing machine to improve its distribution pattern for spreading different types of fertilizers. *Zagazig J. Agric. Res.*, 33 (4): 1349-1371
- Ismail, Z.E., M.M. Ibrahim, M.A. El Saadany and O.A. Fouda (2011). Agitator unit in auger metering devicev for fertilizers applicator. *Ama, Ag. Mech. In Asia, Afr. and Latin Am.*, 42 (3) : 36-41.
- Manian, R., K. Kathirvel and V. Nagaiyan (1999). Development and evaluation of combination tillage-bed furrow-former. *Coll. Agric. Eng., Tamil Nadu Agric. Univ., Coimbatore-641003, India. AMA, Agr. Mech. in Asia, Afr. and Latin Am.*, 30 (4): 22-29.
- Metwalli, S.M. (2004). A loacly manufactured of manure dripper equipment. The 12<sup>th</sup> Conf. of miser Soc. of Agr. Eng., 2004:17-24
- Meselhy, A.A. and M.E. Elhagary (2014). Study the relationship between using the modified ridger and efficiency of surface irrigation system in Ras-sadr area. *Int. J. Adv. Res.*, 2 (7): 1121-1136
- Wagdy, M.M. (1999). Development of broadcaster fertilizer machine to be suitable for Egyptian field. Ph.D. Thesis, Fac. Agric., Zagazig Univ., Egypt.

## تصنيع آلة محلية لإضافة الأسمدة العضوية والكيماوية لزراعة الخضر في الأراضي الرملية

محمد عبدالعظيم أحمد سلامة<sup>١</sup> – محمد محمد مراد حسن<sup>٢</sup> – احمد محمد سعيد القط

١- قسم صيانة الأراضي – مركز بحوث الصحراء – مصر

٢- قسم الهندسة الزراعية – كلية الزراعة – جامعة الزقازيق – مصر

تعتبر عملية إضافة الأسمدة العضوية و الكيماوية بالكميات المناسبة من أصعب العمليات الزراعية التي تواجه المزارع المصري في المناطق حديثة الاستصلاح نظراً لندرة الأيدي العاملة وارتفاع أجرها مما يؤدي إلى زيادة تكلفة الفدان خاصة عند زراعة محاصيل الخضر تحت نظم الري الحديث والتي تحتاج إلى إضافة الأسمدة العضوية والكيماوية في خطوط تحت سطح التربة عند إعداد وتجهيز مرقد البذرة ولذلك فقد تم تصنيع آلة (وحدة مجمعة) تقوم بعدة عمليات في وقت واحد وهي عملية التخطيط وإضافة الأسمدة العضوية والكيماوية وتغطية السماد وتكون الآلة المقترحة من الأجزاء الأساسية الآتية وحدة التخطيط، وحدة إضافة الأسمدة العضوية، وحدة إضافة الأسمدة الكيماوية، وحدة التغطية وقد تم تنفيذ التجارب العملية والحقلية أثناء إعداد لزراعة محصول الفاصوليا بمنطقة جنوب القنطرة شرق محافظة الإسماعلية وكانت أهم النتائج التي تم التوصل إليها: أوضحت نتائج التجارب العملية والحقلية انه عند استخدام الآلة المقترحة بسرعة أمامية ٣,٣ كم/س و سرعة دورانية لعمود التغذية ١٢٠ لفة/ دقيقة وعمق الخط ٢٠ سم أدى ذلك إلى زيادة كلا من الكفاءة الحجمية وانتظامية توزيع السماد وإنتاجية محصول الفاصوليا الخضراء وانخفاض كلا من القدرة المطلوبة و الطاقة المطلوبة.

المحكمون:

- ١- أ.د. زكريا إبراهيم إسماعيل  
٢- أ.د. محمود خطاب عفيفي

أستاذ الهندسة الزراعية – كلية الزراعة – جامعة المنصورة.  
أستاذ ورئيس قسم الهندسة الزراعية – كلية الزراعة – جامعة الزقازيق.