

## DEVELOPING MINCER HOUSEHOLD FOR OPTIMIZATION OF LEEK AIHAM PORRUM

\*Shetawy M. A. El-Said

### ABSTRACT

*This research was carried out in Faculty of Agricultural Engineering, Al-Azhar university, Nasr city during 2016 season to leek cultivated after cutting leaves for slices (length slice 3 cm). The aim of green leek chop is to utilization of producing juicing which is considered as the most effective preparation for securing all health benefits of leek. To achieve this aim, a house mincer household with a (1.5 hp) motor was used. Factors studied were two type sample ( head and lateral ), two moisture content headed ( 69 and 85 % ), lateral (68 and 80 %) and screen hole diameters ( 4, 5 and 6 mm ) at rotation speed (400 , 500 and 600 rpm ) with feeding mass 250 g. The performance of the chop was evaluated according to the chop. Productivity, energy requirements and sample content from protein and Fat. The results showed that the highest productivity was 11.54 kg / h lateral chop and highest productivity was 15.00 kg / h head chop and minimum specific energy 0.01 kw . h / kg lateral chop and minimum specific energy 0.08 kw . h / kg head obtained at 600 rpm and screen hole diameters 7 mm, 80 % moisture content for lateral sample and 85% moisture content for head sample while the requirement power highest 0.252 kw at 3 mm screen hole diameter, 80 % moisture content for lateral sample and 0.17 kw at 5 mm screen hole diameter, 68 % moisture content for lateral sample at rotation speed of 400 rpm, and the analysis of sample protein and fat contents of with lateral and head are (11.96 and 12.14 %) and( 2.55 and 2.57 %) respectively.*

### INTRODUCTION

**W**ww extension umn edu Leeks (*Allium ampeloprasum* var. porrum), family Alliaceae are a gourmet vegetable that may be grown easily. They have a mild onion flavor and are usually used in soup, but they may also be eaten raw, braised, or in casseroles or quiche.

---

\* Assoc. prof. and chairman of Agric. Structures and environmental control Eng. Dept. Fac. of Agric. Eng., Al-Azhar Univ.

It can be added in poultry and animal fodder. In Egypt, leek cultivated area about 2225 feddan which produced about 39,160 ton. Leeks resemble overgrown green onions, with a long, cylindrical white shaft, but the leaves are thick, flat and folded. Plants grow to 60 – 90 cm in height. The edible portion is the shaft, usually 15 - 25 cm long and up to 5 cm in diameter.

**Leek – friend of the human body (2012)** Leek has nutritional value as the same as onion and garlic. Leek contains more protein than the garlic and onion. Beta carotene, Vitamin C, which is mostly contained in the green leaves of the leek. It is rich in minerals: manganese, folic acid, iron, magnesium, phosphorus, calcium, potassium. It is low calorie. It has an antibiotic effect, the presence of the allicin active antibiotic substance puts leek on the list of natural antibiotics. The use of leek in the diet, contributes to lowering of the blood pressure and the level of cholesterol in the blood. Leek is a natural preventive medicine for cardiovascular diseases. Strengthens the immune system and helps with colds and infections. Leek is rich in essential oils which increase the secretion of digestive juices and thus improve digestion. Leek is listed among natural diuretics because it contains a lot of potassium (300mg. potassium in 100gr. leek) and little sodium. It increases the secretion of liquids and toxic substances through the kidneys. Leek is often recommended to people with cardiovascular and kidney diseases, to reduce swellings. Because of this characteristic of his, leek is a natural “cleaner” of toxins. It contains vitamin E and carotene, which are important for healthy, elastic and gentle skin. Leek contains possible antioxidants which protect the organism from the negative influence of the free radicals, which can cause development of many chronic diseases, including cancer. Contains little fat and sugar, and a lot of cellulose which causes feeling of satiety, and thus it is ideal for maintaining a normal body weight during the winter.

Leek considered garlic family is as the most important and garlic products are being promoted in the form of volatile oils, juices, extracts in liquid and dried forms and macerates for utilization in pharmaceuticals and food preservation. Series of antioxidant activity they are antiatherosclerotic, antihypertensive,

antimicrobial, anticancer, immunomodulation, and radioprotection (Zeng et al.,2008). Garlic is a potent natural antibiotic, it has anti-fungal and anti-viral properties and it has anti-oxidant properties. (khanum et al.,1998). To extract garlic juice the fresh garlic is milled to obtain a medium structured mash. Then the mash is pumped into a buffer tank where it is left for 15-60 min to complete enzymatic reactions. Juice extraction is done either by pressing or decantation. The juice is adjusted to the desired pH and passed through preheated. The juice is sterilized for few seconds after preheating (Santhosha et al. 2013). Leek juices is the most effective of the commercial preparation for obtaining all the health benefits of leek cloves are sliced, dried and then ground into powder before the allicin is formed (Gara et al., 2000).

The main objective of this research is to test and performance evaluation of a small house mincer during cutting and crushing (chop) green leek. the optimize operating parameters

### MATERIALS AND METHODS

The experiments were carried out at Faculty of Agricultural Engineering Al-Azhar University, Nasr City during 2016 season for house mincer.

#### **Raw materiel:**

Fresh leek cultivars were selected to apply this study after cutting and chop about 3 cm length as in Fig (1). with two moisture content (69 and 85 %) of head and (68 and 80 % ) for lateral.

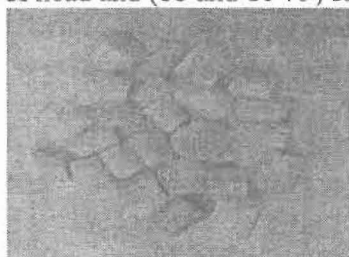

(A)

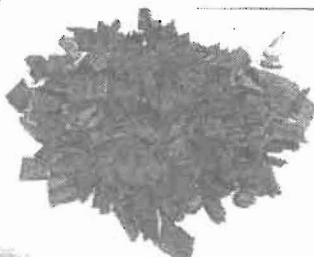

(B)

**Fig. (1): Photo of green leek head (A) and lateral (B).**

#### **Mincer household prototype:**

The prototype of mincer was constructed and fabricated in the workshop of Agricultural Engineering Faculty, Al-Azhar University, Nasr city, Cairo, Egypt. The prototype consists of house mincer, electric motor (1.5

Hp) and metal frame as in Fig (2 and 3). During this study the following parameter were tested: three screen holes diameter of 5, 6 and 7 mm, three speed of mincer of 400, 500 and 600 rpm and two moisture content of 69 and 85 % for head and 68 and 80 % for lateral.

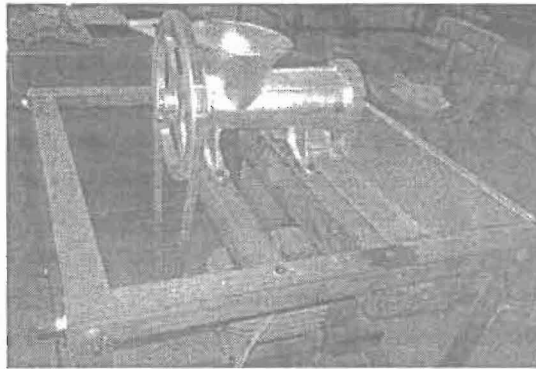

Fig. (2):

Photograph of chop prototype

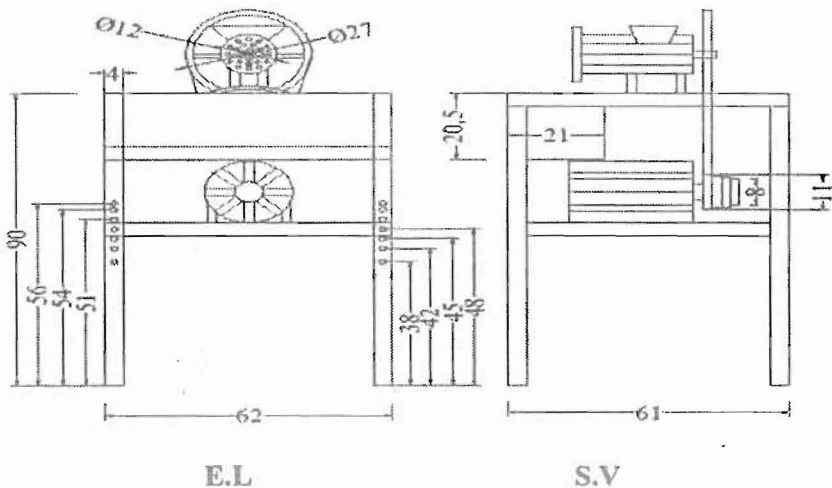

Fig. (3): Elevation and side view of mincer prototype .

#### Measurements

##### 1 – Moisture content:

The moisture content " $M_c$ " was measured according to the ASAE standard (1994) by taking a sample. The average moisture content was

determined in (d.b) basis by using oven method at 377°K ( 105° C) for 24 hours and calculated by the following equation:

$$MC \% = ( M_w - M_d ) / M_d \dots\dots\dots (1)$$

Where:

- MC : moisture content (%).
- M<sub>w</sub> : sample mass before drying ( g).
- M<sub>d</sub> : mass of dried sample (g)

**2- Dimensional Characteristics of Fruit :**

Characteristic dimensions as length “a and thickness “t” (mm) were measured by using digital dial caliber (accuracy of 0.01). These physical characteristics can be utilized effectively in machines design. Random samples of fifty fruit were taken. The three major dimensions, length (parallel with the longitudinal axle "a") and thickness (perpendicular on the longitudinal axle "b").

**3- Mass of Fruit:**

A random sample of fifty fruit were taken and weighed by an electric digital balance model: 1431MB8-1 and of accuracy 0.01g.

**4- Bulk density:**

The bulk density was calculated for the fruits by dividing the mass of quantity of fruits on its volume.

$$\rho_d = \frac{W_s}{V_s} \dots\dots\dots (2)$$

Where:

- ρ<sub>d</sub> : Bulk density of fruits, (g/cm<sup>3</sup>); W<sub>s</sub> : Mass of the quantity of fruits, (g); and V<sub>s</sub> : Volume of the quantity of fruits, (cm<sup>3</sup>).

**5 – Productivity:**

Juicing time of 250 g of green leek head and leaves were measured by means of a stopwatch to determine the house mincer productivity in kg/ h.

$$\text{Productivity} = \frac{\text{Mass of green leek leaves (kg)}}{\text{Time of green leek ( h )}} \dots\dots\dots (3)$$

**6 –power requirements:**

A digital AVO meter was used for measuring the current Amber before and during experiments the total consumed electric power under working

load (kW) was calculated according ( Lockwood and Denstan, 1971) by the following equation.

$$\text{Power (kw)} = \frac{( I . V . \eta . \cos \alpha )}{1000} \dots\dots\dots (4)$$

Where:

- I : Current strength in Amperes.
- V: Voltage strength ( equal to 220 V ),
- Cosα : Power factor ( equal to 0.85) and
- η : Mechanical efficiency assumed to be ( 90 %)

**7 – Specific energy requirement:**

The specific energy requirement ( kW . h / kg ) was calculated by using the following equation.

$$\text{Specific energy requirement} = \frac{\text{Power ( kW )}}{\text{Productivity (kg / h)}} \dots\dots (5)$$

**8 – Sample content from Protein and Fat**

The analysis of the sample content from protein and fat with two moisture content of head and lateral used Appliance (NIRA-DA-1650 FOSS).

**RESULTS AND DISCUSSION**

**The major dimensions:**

Averages of three tow major dimensions of green leek length head diameter are shown in table (1). The measurements of length (a) and diameters (d) in (cm) of fifty fruits, randomly selected, were conducted. The highest value of fruit length and thickness was 14 and 2.6 cm respectively, while the lowest value of fruit length and diameter are 2.6 and 1.1 cm respectively.

**Table (1): The 2 - Major dimensions of green leek head:**

Dimensions	Max.	Min.	Ave.	S.D	C.V %
Length (cm)	14	6	9.59	2.05	21.37
diameter (cm)	2.6	1.1	1.79	0.36	20.11

Figs. (4 and 5) showed that the highest frequency of green leek head length and diameter ware 42 and 40% at (8.1 – 1.0 cm) and (1.5 – 1.8cm) respectively.

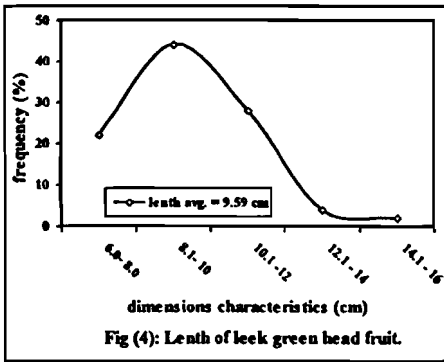

Fig (4): Length of leek green head fruit.

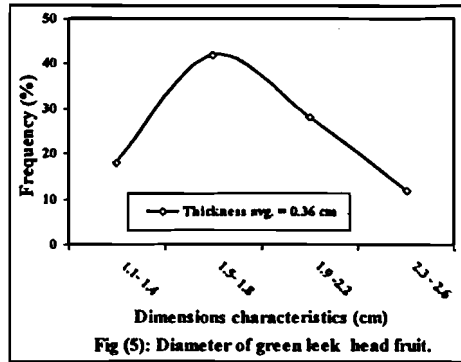

Fig (5): Diameter of green leek head fruit.

Averages of two major dimensions of green leek lateral are shown in table (2). The measurements of length (a) and diameter (d) in (cm) of fifty fruits, randomly selected, were conducted. The highest value of fruit length and diameter were 72 and 2.4 cm respectively, while the lowest value of fruit length and diameter were 2.4 and 1.1 mm respectively.

Table (2): Tow major dimensions of green leek lateral:

Dimensions	Max.	Min.	Ave.	S.D	C.V %
Length (cm)	72	43	52.58	8.76	16.66
Thickness (cm)	2.4	1.1	1.78	0.45	25.28

Figs. (6 and 7) showed that the highest frequency of green leek lateral length and diameter were 45 and 33% at (3.4 – 3.6 cm) and (1.4 – 1.5cm) respectively.

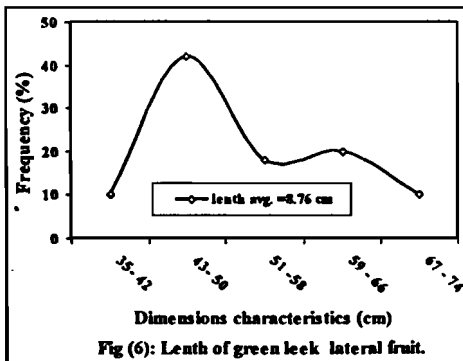

Fig (6): Length of green leek lateral fruit.

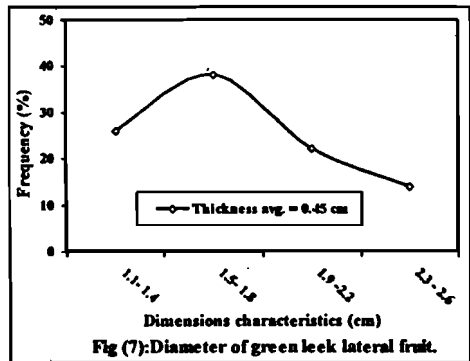

Fig (7): Diameter of green leek lateral fruit.

**bulk density of head and lateral :**

The measurements of mass and bulk density of green leek head and lateral under study . were conducted in three replicates. Table (3) shows that the head fruits gave values of 1245 (g) and 0.27 (g/cm<sup>3</sup>) for mass and bulk density respectively. Also, it shows that the lateral fruits gave values of 2098g and 0.098 g/cm<sup>3</sup> for mass and bulk density respectively. The percentage of the head mass to the lateral mass was about 59.34 %.

**Table (3): The mass and bulk density of fifty fruits of green leek head and lateral.**

	Bulk density (g/cm <sup>3</sup> )
Head	0.27
Lateral	0.098

**Effect of screen holes diameters, mincer speed and moisture content on mincer productivity:**

Fig. (8) showed the relationship between the screen holes diameters and mincer productivity (kg/h) at different tree mincer speed for leek head at moisture content of 85 w.b %. The obtained data showed that the mincer productivity increased with increase of both screen holes diameters and mincer speed, The maximum value of mincer productivity was (15 kg/h) at screen holes diameter of 7 mm and mincer speed of 600 rpm, while the lower value of mincer productivity was (5 kg/h) at screen holes diameter of 5 mm and mincer speed of 400 rpm

Fig. (9) showed the relationship between the screen holes diameters and mincer productivity (kg/h) at different tree mincer speed for leek head at moisture content 69 w.b %. The obtained data showed that the mincer productivity increased with increasing of both screen holes diameters and mincer speed. The maximum value of mincer productivity was (11.19 kg/h) at screen holes diameter of 7 mm and mincer speed of 600 rpm, while the lower value of mincer productivity was (4.09 kg/h) at screen holes diameter of 5 mm and mincer speed of 400 rpm



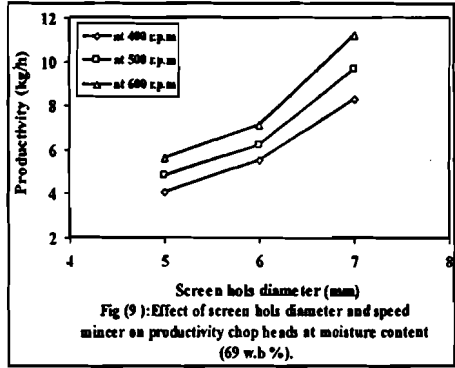
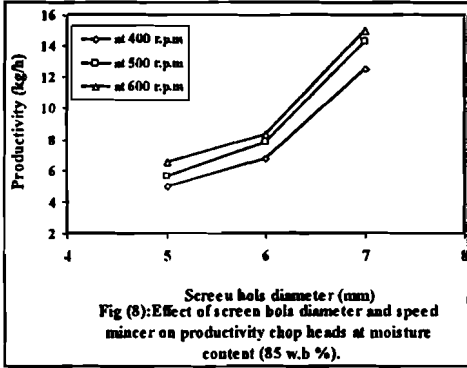
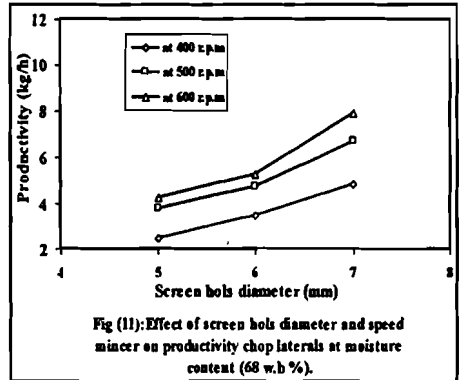
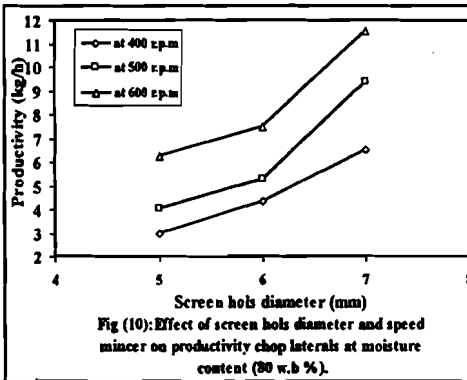

Fig. (10) showed the relationship between the screen holes diameters and mincer productivity (kg/h) at different tree mincer speed for leek head at moisture content 80 w.b %. The obtained data showed that the mincer productivity increased with increase of both screen holes diameters and mincer speed, The maximum value of mincer productivity was (11.54 kg/h) at screen holes diameter of 7 mm and mincer speed of 600 rpm, while the lower value of mincer productivity was (3.11 kg/h) at screen holes diameter of 5 mm and mincer speed (400rpm)

Fig. (11) showed the relationship between the screen holes diameters and mincer productivity (kg/h) at different tree mincer speed for leek head at moisture content 68 w.b %.



The obtained data showed that the mincer productivity increased with increasing of both screen holes diameters and mincer speed, The maximum value of mincer productivity was (7.89 kg/h) at screen holes diameter of 7 mm and mincer speed of 600 rpm, while the lower value of mincer

productivity was 2.5 kg/h) at screen holes diameter of 5 mm and mincer speed of 400 rpm.

**Effect of screen holes diameters, mincer speed and moisture content on mincer specific energy:**

Fig. (12) showed the relationship between the screen holes diameters and specific energy requirement (kW.h/kg) at different there mincer speed for leek head at moisture content (85 w.b %). The obtained data showed that the specific energy requirement (kW.h/kg) decreased with increase of both screen holes diameters and mincer speed, The maximum value of mincer specific energy. was (0.29 kW.h/kg ) at screen holes diameter of 5 mm and mincer speed of 400 rpm, while the lower value of Specific energy requirement was (0.005 kW.h/kg) at screen holes diameter of 7mm and mincer speed of 600 rpm

Fig. (13) showed the relationship between the screen holes diameters and Specific energy requirement (kW.h/kg) at different tree mincer speed for leek head at moisture content 69 w.b %. The obtained data showed that the specific energy requirement (kW.h/kg) decreased with increaing of both screen holes diameters and mincer speed.The maximum value of mincer specific energy. was (0.04 kW.h/kg) at screen holes diameter of 5 mm and mincer speed of 400 rpm, while the lower value of mincer productivity was (1.01 kW.h/kg) at screen holes diameter of 7 mm and mincer speed of 600 rpm

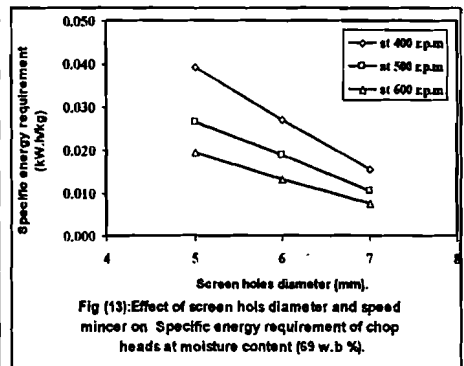
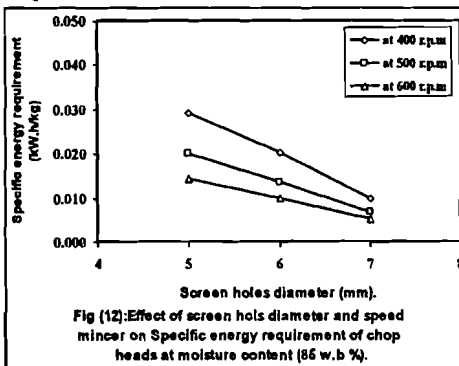

Fig. (14) showed the relationship between the screen holes diameters and Specific energy requirement (kW.h/kg) at different tree mincer speed for leek lateral at moisture content 80 w.b %. The obtained data showed that the

Specific energy requirement (kW.h/kg) decreased with increase of both screen holes diameters and mincer speed, The maximum value of mincer specific energy. was (0.05 kW.h/kg ) at screen holes diameter of 5 mm and mincer speed of 400 rpm, while the lower value of specific energy requirement was (0.01 kW.h/kg) at screen holes diameter of 7mm and mincer speed of 600 rpm

Fig. (15) showed the relationship between the screen holes diameters and Specific energy requirement (kW.h/kg) at different tree mincer speed for leek lateral at moisture content 68 w.b %. The obtained data showed that the specific energy requirement (kW.h/kg) decreased with increase of both screen holes diameters and mincer speed. The maximum value of mincer specific energy. was (0.07 kW.h/kg) at screen holes diameter of 5 mm and mincer speed of 400 rpm, while the lower value of mincer productivity was (0.01 kW.h/kg) at screen holes diameter of 7 mm and mincer speed of 600 rpm

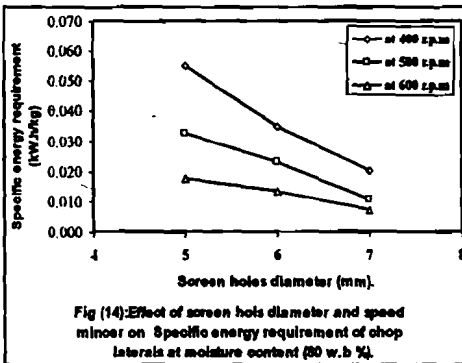

Fig (14):Effect of screen holes diameter and speed mincer on Specific energy requirement of chop laterals at moisture content (80 w.b %).

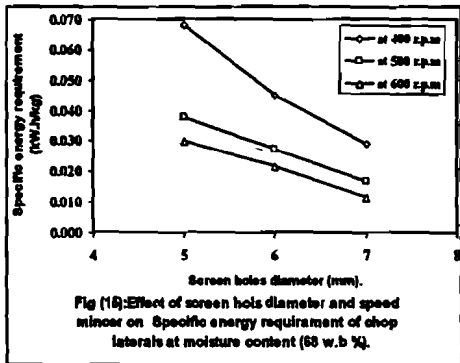

Fig (15):Effect of screen holes diameter and speed mincer on Specific energy requirement of chop laterals at moisture content (68 w.b %).

**Effect of screen holes diameters, mincer speed and moisture content on bulk density of green leek chopped:**

Fig. (16) showed the relationship between the screen holes diameters and bulk density (g/cm<sup>3</sup>) at different three mincer speed for leek head at moisture content (85 w.b %). The obtained data showed that the bulk density decreased with increase of both screen holes diameters and mincer speed. The maximum value of mincer bulk density was (0.655 g/cm<sup>3</sup>) at screen holes diameter of 5 mm and mincer speed of 400 rpm, while the lower value of mincer bulk density was (0.524 g/cm<sup>3</sup>) at screen holes diameter of 7 mm and mincer speed of 600 rpm.

Fig. (17) showed the relationship between the screen holes diameters and bulk density ( $\text{g}/\text{cm}^3$ ) at different tree mincer speed for leek head at moisture content 69 w.b %. The obtained data showed that the bulk density decreased with increase of both screen holes diameters and mincer speed, The maximum value of mincer bulk density was ( $0.639 \text{ g}/\text{cm}^3$ ) at screen holes diameter of 5 mm and mincer speed of 400 rpm, while the lower value of mincer bulk density was ( $0.504 \text{ g}/\text{cm}^3$ ) at screen holes diameter of 7 mm and mincer speed of 600 rpm.

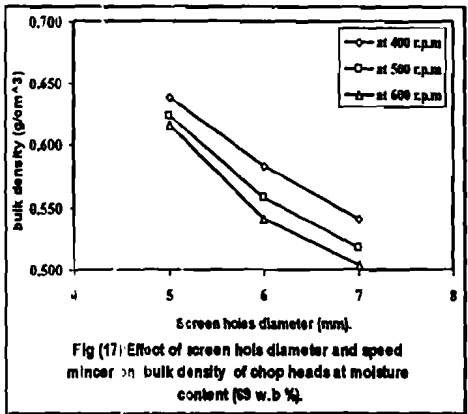
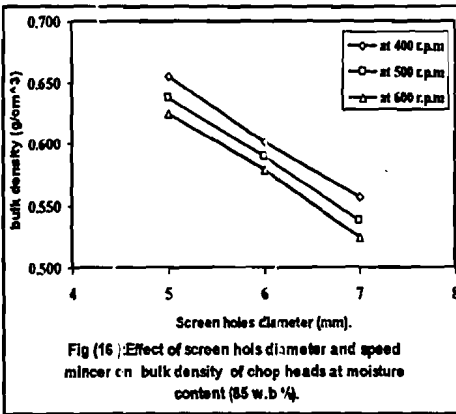
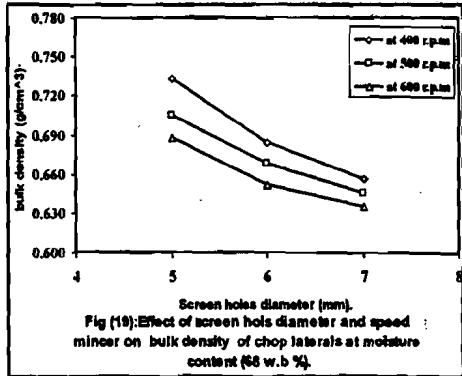
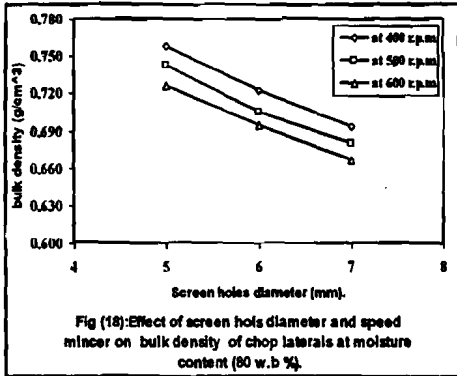

Fig. (18) showed the relationship between the screen holes diameters and bulk density ( $\text{g}/\text{cm}^3$ ) at different tree mincer speed for leek head at moisture content 80 w.b %. The obtained data showed that the bulk density decreased with increase of both screen holes diameters and mincer speed, The maximum value of mincer bulk density was ( $0.758 \text{ g}/\text{cm}^3$ ) at screen holes diameter of 5 mm and mincer speed of 400 rpm, while the lower value of mincer bulk density was ( $0.667 \text{ g}/\text{cm}^3$ ) at screen holes diameter of 7 mm and mincer speed. of 600 rpm.

Fig. (19) showed the relationship between the screen holes diameters and bulk density ( $\text{g}/\text{cm}^3$ ) at different tree mincer speed for leek head at moisture content 68 w.b %. The obtained data showed that the bulk density decreased with increase of both screen holes diameters and mincer speed. The maximum value of mincer bulk density was ( $0.733 \text{ g}/\text{cm}^3$ ) at screen holes diameter of 5 mm and mincer speed of 400 rpm, while the lower value of mincer bulk density was ( $0.635 \text{ g}/\text{cm}^3$ ) at screen holes diameter of 7 mm and mincer speed of 600 rpm.



**Sample content from Protein and Fat**

The obtained sample content by chemical analysis. Ratio of protein, Fat used two sample (lateral and head) was ( 11.96 and 2.55 %), ( 12.14 and 2.57 %) respectively.

**REFERENCES**

ASAE standard (1994). Standards, Engineering Practices Data. ISBN 0-920355-50.4 Library of Congress. American Society of Ag. Eng: 450.

Grahame, D (2005) Production yearbook for 1990. Horticultural marketing. Food and Agriculture Organization of the united nations, Rome.

Gara, O.E.:D. Hill and D. Maslin (2000) Activities of garlic powder and their dually constituents against helicobacter pyiori. Applied and environmental microbiology . 66: 5, 2268- 2273.

Khanum, F.: K. R. Anilkumar: K. R. Sudarshanakrishna and K.R. Viswanathan (1998) Effects of feeding fresh garlic and garlic oil on detoxifying enzymes and micronuclei formation in rats treated with azoxymethane. Intemational J. for vitamin and nutrition Res., 68: 3. 208 – 212.

Santhosha, S.G.: P. Jamuna AND S.N. Prabhavathi (2013) Bioactive components of garlic and theirphysiological role in health maintenance: A review" Food Bioscience 3: 58 – 74.

Zeng, T.:F.F. Guo: C. L. S. Zhao: D.D. Dou: X.C. and K.Q. Xie (2008) The anti-fatty liver effects garlic oil on acute ethanol exposed mice" Chemical Biological Interactions. 176 : 231 – 242.

www.extension.umn.edu - Copyright © 2008, Regents of the University of Minnesota. All rights reserved. Order additional copies at <http://shop.extension.umn.edu> or call (800) 876-8636.

Leek – friend of the human body (2012). 13 properties of leek which are beneficial for the human body., Healthy Food [www.healthyfoodcorner.com](http://www.healthyfoodcorner.com).

### المخلص العربي

## تطوير المفرمة المنزلية لتعظيم الاستفادة من الكرات

د/ محمد أحمد شتيوي\*

يعتبر الكرات من محاصيل الخضر في مصر وله أهمية كبيرة حيث يستخدم في كثير من الصناعات الغذائية بالإضافة إلى الاستخدام المنزلي ويدخل في كثير من الاستخدامات الطبية ويعمل كمضاد حيوي في مزارع الدواجن . وتم إجراء هذا البحث خلال موسم ٢٠١٦ م في كلية الهندسة الزراعية جامعة الأزهر.

ويهدف البحث إلى الاستفادة من محصول الكرات الأخضر عن طريق فرمها للاستفادة المنزلية خلال العام كله حيث تم الفرمة آلة لفرم الكرات قدرته ١.٥ حصان ، وللوصول إلى هذا الهدف تم اختيار عينتان للفرم (الراس والأوراق) بنسب رطوبة ( ٨٥ و ٦٩ % للراس) ( ٨٠ و ٦٨ % للأوراق) وثلاث فتحات للفرم ( ٥ ، ٦ ، ٧ مم ) وتقطيعها إلى شرائح طولها ٣ سم مع سرعة سكينه للخلاط ٤٠٠،٥٠٠ لفة / د والكرات المستخدم ( الصنف البلدي ). وتم تقييم أداء المفرمة من خلال إنتاجية المفرمة والقدرة المطلوبة والطاقة النوعية المطلوبة للفرم والكثافة قبل وبعد الفرمة والنسبة المئوية لمحتوي العينة من البروتين والدهون للراس والعروش وكانت أهم النتائج:

- كانت اعلي إنتاجية للآلة ١٥ كجم / س للراس مع نسبة رطوبة ٨٥ % و ١١.٥٤ كجم / س للأوراق مع نسبة رطوبة ٨٠ % عند استخدام فتحة ٧ مم وسرعة دوران للآلة ٦٠٠ لفة / د .
- كانت اعلي قدرة مطلوبة للفرم ٠.١٦ كيلوات عند نسبة رطوبة ٦٩ % للراس وكانت ٠.١٧ كيلوات للأوراق مع نسبة رطوبة ٦٨ % مع استخدام فتحة ٥ مم وسرعة دوران للآلة ٤٠٠ لفة / د
- كانت اقل طاقة نوعية مطلوبة للآلة ٠.٠٠٥ كيلوات . س / كجم عند نسبة رطوبة ٨٥ % للراس وكانت ٠.٠٠٧ كيلوات . س / كجم للأوراق عند نسبة رطوبة ٨٠ % مع استخدام فتحة ٧ مم وسرعة دوران للآلة ٦٠٠ لفة / د
- كانت أعلى كثافة بعد الفرمة ٠.٦٣٩ جم/سم<sup>٣</sup> عند نسبة رطوبة ٦٩ % للراس وكانت ٠.٧٥٨ جم/سم<sup>٣</sup> للأوراق عند نسبة رطوبة ٨٠ % مع استخدام فتحة ٥ مم وسرعة دوران للآلة ٤٠٠ لفة / د
- وقد أظهرت نتائج التحليل الكيمائي أن نسبة البروتين والدهون للراس والأوراق ( ١٢.١٤ و ١١.٩٦ % ) بروتين و ( ٢.٥٧ و ٢.٥٥ % ) دهون.

\* أستاذ ورئيس قسم المنشآت الزراعية والتحكم البيئي المساعد بكلية الهندسة الزراعية- جامعة الأزهر.